

**Artweger**<sup>®</sup>

The fine ART of bathing

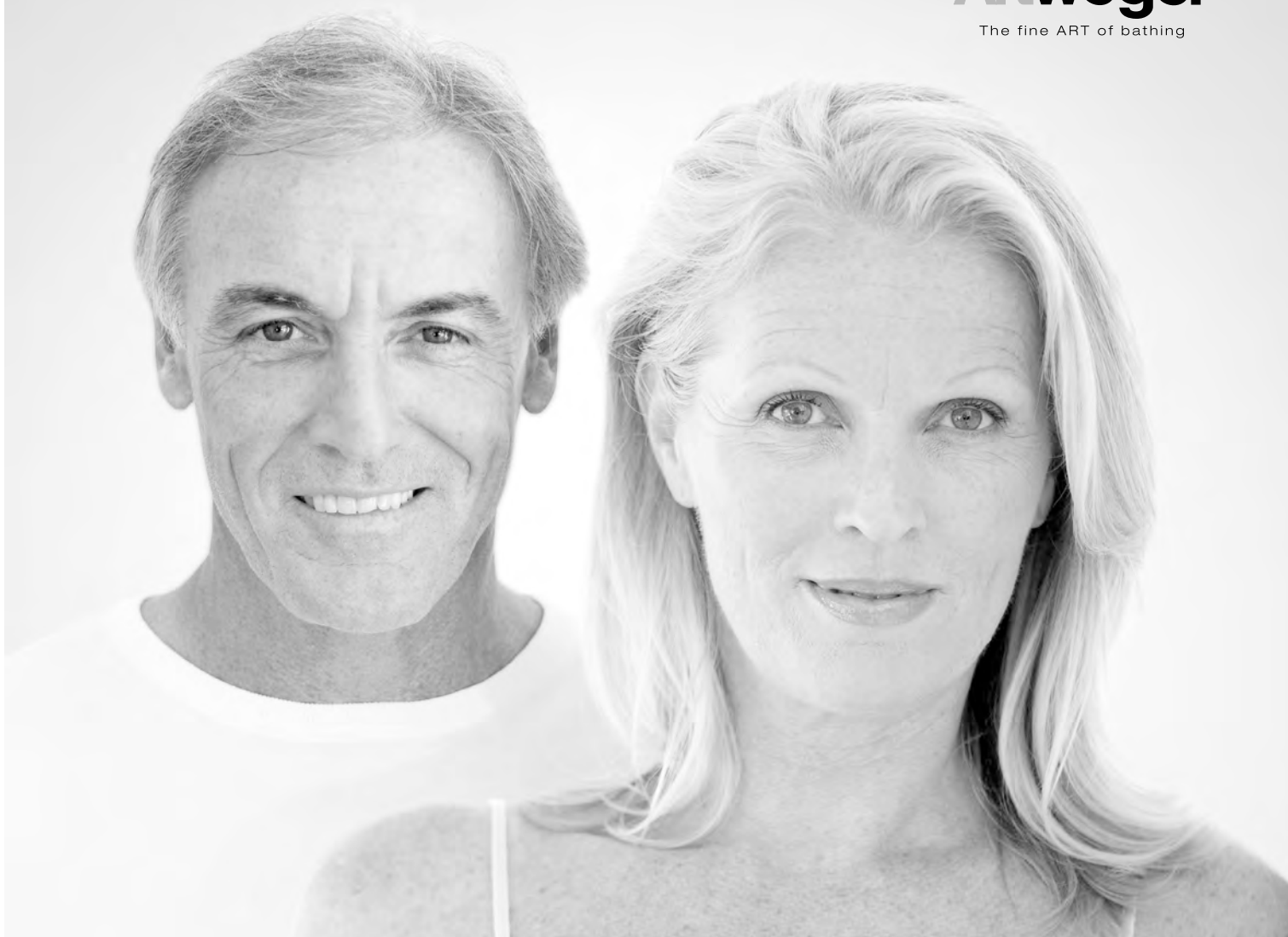

11768\_09\_22

# PRE-INSTALLATION DOCUMENTS



Your guarantee for mobility in the bathroom.

# ARTLIFT

Shower. Bath. Seat Lift.

**ENGLISH** Translation

### CONTENTS

<b>PRE-INSTALLATION - NOTES .....</b>	<b>2</b>
<b>PROTECTED AREAS .....</b>	<b>2</b>
<b>CONTENTS .....</b>	<b>3</b>
<b>ARTWEGER ARTLIFT Required work space .....</b>	<b>4</b>
» <b>INSTALLATION - on completed floor .....</b>	<b>5</b>
» <b>INSTALLATION ON STRAIGHT WALL - on completed floor.....</b>	<b>5</b>
» <b>INSTALLATION - on raw concrete (casing dimensions) .....</b>	<b>6</b>
» <b>ODOUR-TRAP installation area .....</b>	<b>6</b>
» <b>SERVICE AREA, ARTLIFT-Tub &amp; pre-fitting kit.....</b>	<b>7</b>
» <b>WIRING diagram .....</b>	<b>7</b>
<b>ARTWEGER ARTLIFT Required work space .....</b>	<b>8</b>
» <b>INSTALLATION - on completed floor .....</b>	<b>9</b>
» <b>INSTALLATION ON STRAIGHT WALL - on completed floor.....</b>	<b>9</b>
» <b>ODOUR-TRAP installation area .....</b>	<b>10</b>
» <b>Plan de câblage .....</b>	<b>11</b>

*All the pictures refer to installing models with entry on the left.  
For models with entry on the right, install symmetrically to the pictures.*

### PRE-INSTALLATION - NOTES

Water inlet and outlet according to DIN 1986 and DIN 1986 as with a normal bathtub.  
In case of the integrated tub inlet (optional equipment) a pipe interrupter (type A2) according to EN 1717 is to be installed.

A pipe interrupter must be installed in accordance with the valid local standards and regulations!

Ensure that on-site preparations adhere to country-specific standards, e.g. ÖNORM B 2207 or DIN 18515-1 (standards for tiling/sealing against dampness). (Seal the splash area and the entire floor area with liquid sealing foil!)

**The two walls that the tub is mounted on must be at an exact 90-degree angle to one another.**



Electrical installation may only be carried out by a qualified, registered company in compliance with legislation guidelines as well as the currently valid edition of national installation regulations (e.g.; Austria OVE-E-8101; Germany DIN VDE 0100-701). Cable duct from above or below (min. 20 mm Ø, min. installation depth 5 cm). Separate mains supply line H05-VV-F (flexible line) over a RCD  $\Delta I_N \leq 30$  mA. For connection a cable of approx. 3 m should be provided. Take care to comply with current regulations about potential equalization! Potential equalization line, 4 mm<sup>2</sup> (Cu) for connection to the standard ground terminal.

The line has to have a double-pole cut-off, with a min. 3 mm contact opening (outside of protected zone 2, e.g. protection switched over light switch with control indicator) in accordance with VDE 0100-701 respectively OVE-E-8101.

### PROTECTED AREAS

For your personal safety, the protected areas must be adhered to exactly.

■ = Protected area 2:  
(Height 225 cm) No switches or power outlets allowed!

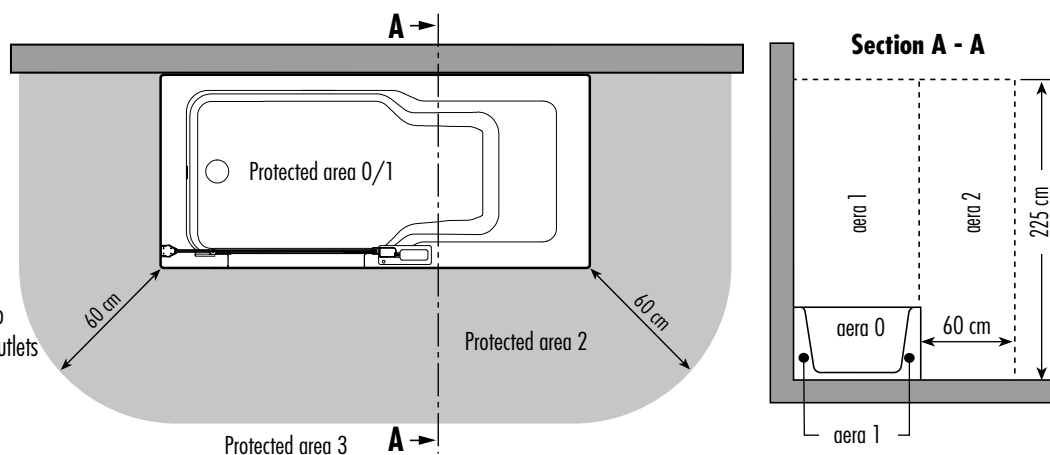

### ARTWEGER ARTLIFT Required work space

Do not install any fixtures or other protruding parts in this area!

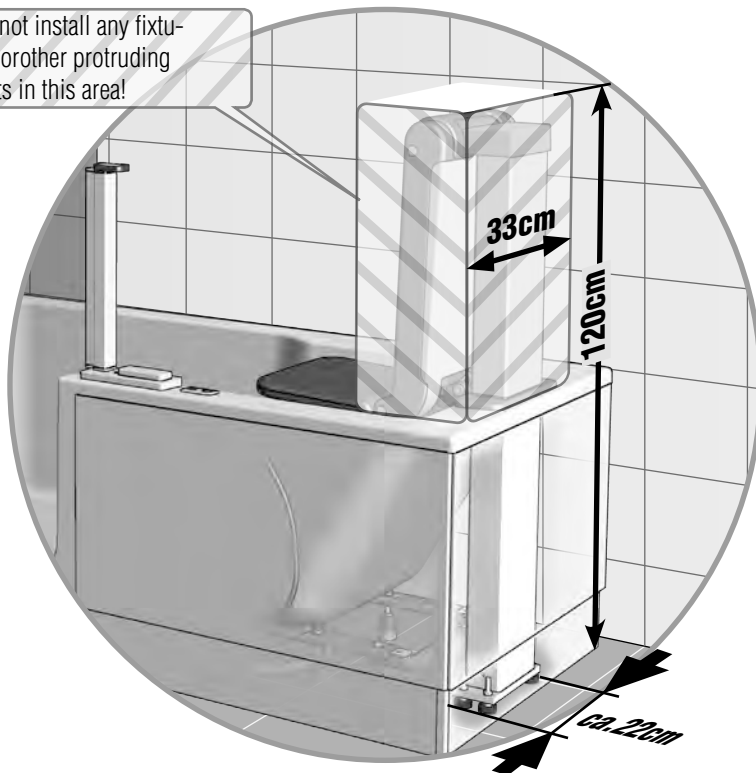

Min. 5cm (if cladding exists)  
to 10cm

Min. 12cm (if cladding exists)  
10cm to 20cm

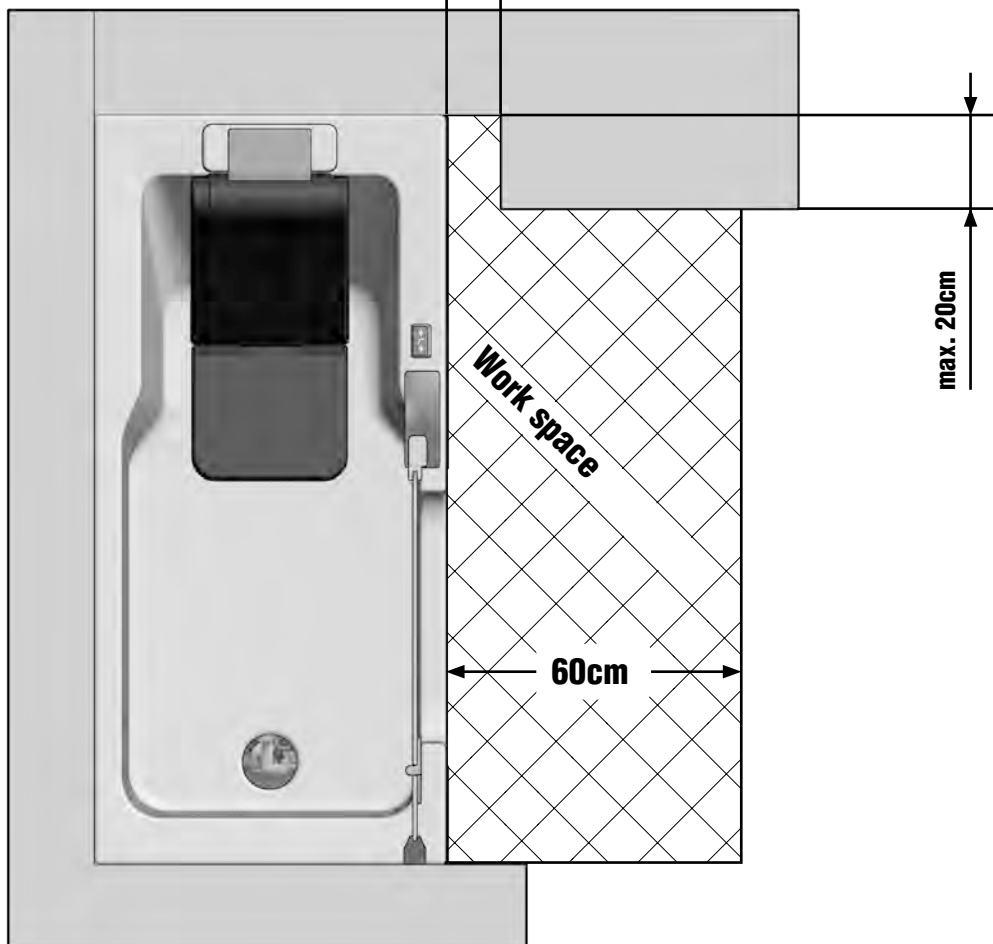

### INSTALLATION - on completed floor

	160/75	170/75	170/80	180/80
<b>k</b>	55	55	60	60

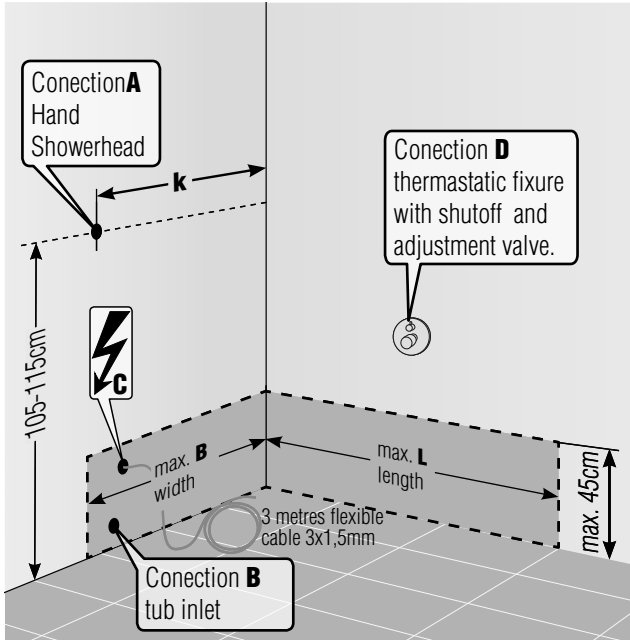

When installing the shower door on the already tiled wall a 1.2 cm compound bracket is required. Do not tile tub **before installation!**

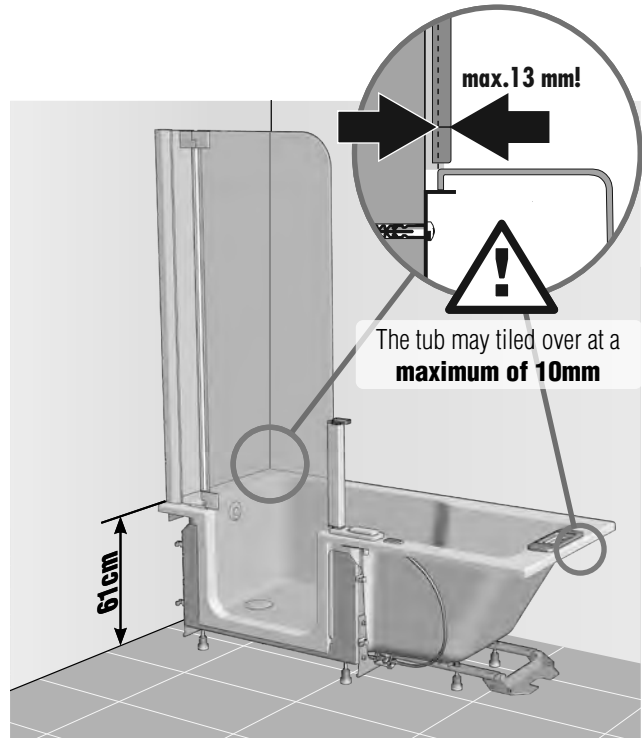

The area **under the tub** must also be **completely tiled!** However, the walls must **not be tiled**

### INSTALLATION ON STRAIGHT WALL - on completed floor

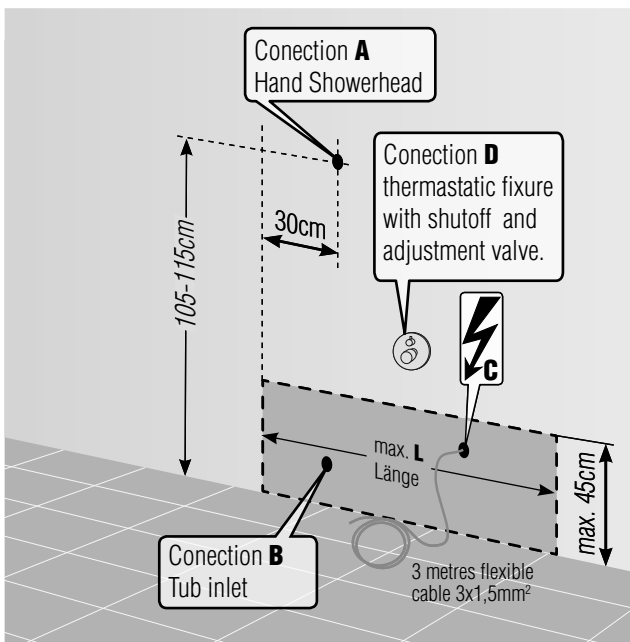

When installing the shower door on the already tiled wall a 1.2 cm compound bracket is required. Do not tile tub **before installation!**

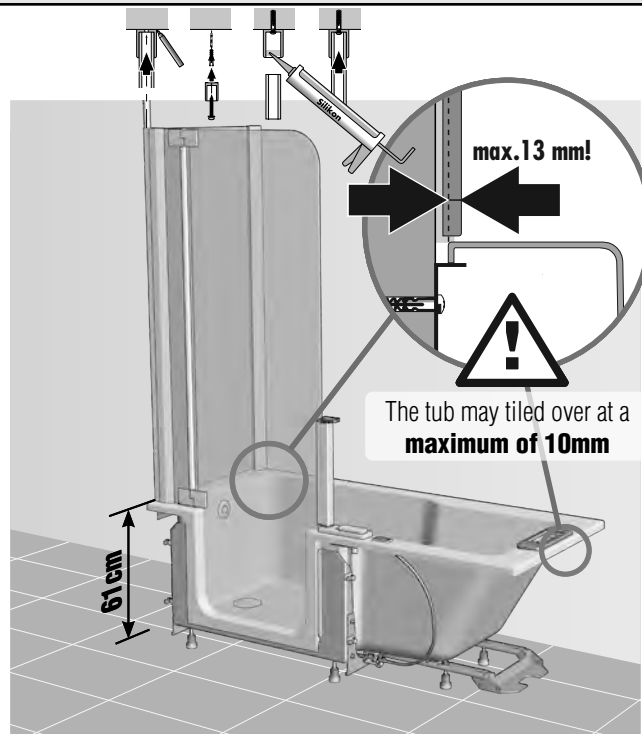

The area **under the tub** must also be **completely tiled!** However, the walls must **not be tiled**

### INSTALLATION - on raw concrete (casing dimensions)

Water (B) and electrical (C) connections possible only within designated areas!

	B	L
<b>160/75</b>	70	155
<b>170/75</b>	70	165
<b>170/80</b>	75	165
<b>180/80</b>	75	175

**IMPORTANT!** The dimensions of the casing must be observed exactly!

The tub can be set **exactly 13cm lower!**

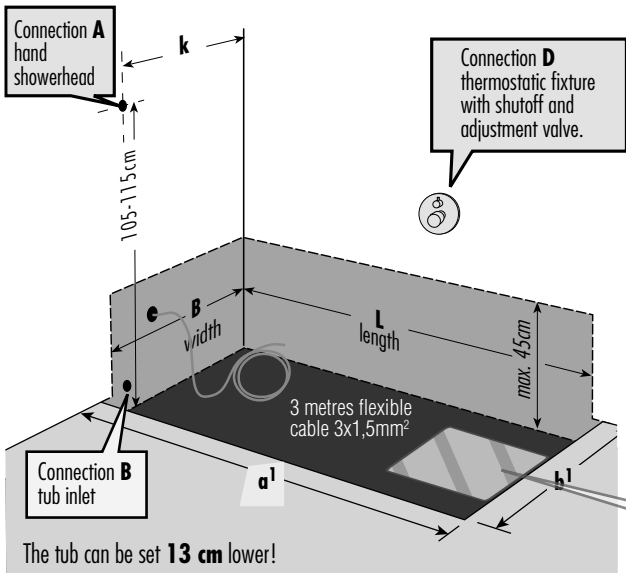
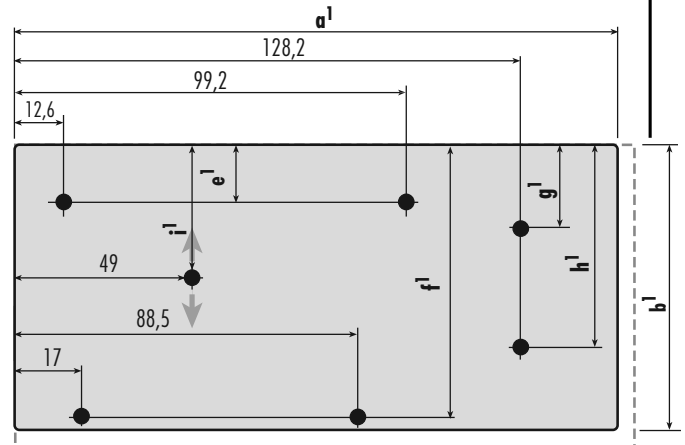

Tub	a <sup>1</sup>	b <sup>1</sup>	e <sup>1</sup>	f <sup>1</sup>	g <sup>1</sup>	h <sup>1</sup>	i <sup>1</sup>
<b>160x75</b>	158	73,5	14,5	68,7	21,2	51	37,5
<b>170x75</b>	168	73,5	14,5	68,7	21,2	51	37,5
<b>170x80</b>	168	78,5	19,5	93,7	26,2	56	40
<b>180x80</b>	178	78,5	19,5	73,7	26,2	56	40

**Base area of the bath lift is ca. 40cm x 50cm!**  
Flat area with no pipes!

Measurements in cm!

### ODOUR-TRAP installation area

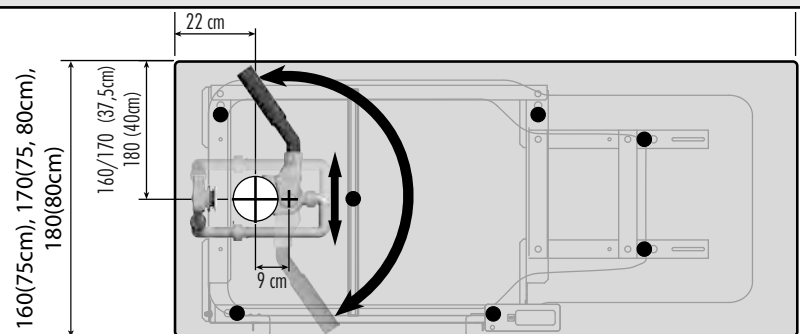

TWINLINE\_2\_Vorinstallation\_DE\_TB/STÖ\_11714\_11\_11

Hauteur de raccordement du siphon

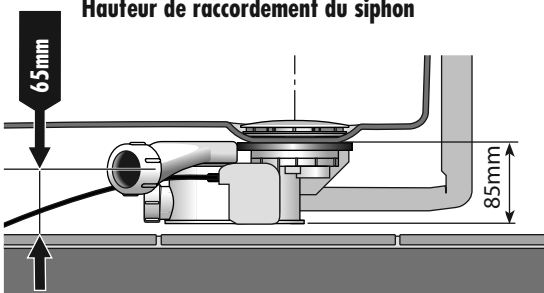

Total height incl. shower screen	211 cm
Room height required	+4,0 cm
Entry height	18,5 cm
Drain	Ø50 mm

### SERVICE AREA, ARTLIFT-Tub & pre-fitting kit

Possible combinations	Voltage rating / frequency	max. power
1. Artlift	230V ~ 50Hz	120 Watt
2. Artlift pre-installation set + coloured light	230V ~ 50Hz	7 Watt
3. Artlift + coloured light	230V ~ 50Hz	130 Watt

L ○  
N ○  
PE ○

FI-Schutzschalter  $\Delta$ IN 30 mA, FI circuit breaker  $\Delta$ IN 30 mA, Interrupteur de sécurité FI  $\Delta$ IN 30 mA  
FI-aardlekschakelaar  $\Delta$ IN 30 mA, salvavita RCD  $\Delta$ IN 30 mA.

Leitungs-Schutzschalter max. 16A, Automatic cutout 16A max., Interrupteur de sécurité courant max. 16A,  
2-polige schakelaar max. 16A, fusibile max. 16A.

Schütz, Contactor, Fusible, Zekering, Relais.

Hauptschalter mit Kontrolllampe im Bad, Main switch with control light in bathroom,  
Interrupteur principal avec lampe de contrôle dans la salle de bain,  
Hoofdschakelaar met controlelamp in de badkamer,  
interruttore con luce di controllo nel bagno

Außerhalb des Schutzbereiches, Outside of protected area, En dehors de la délimitation de protection,  
Buiten de veiligheidszone, al di fuori della zona di sicurezza

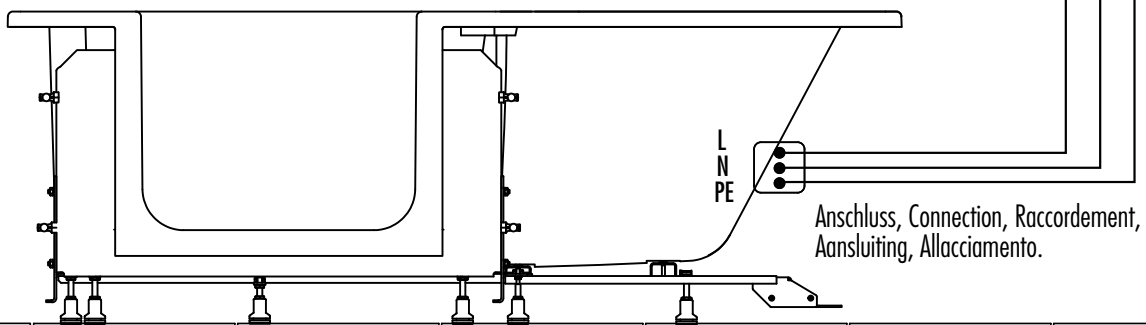

Anschluss, Connection, Raccordement,  
Aansluiting, Allacciamento.

# ARTWEGER ARTLIFT Required work space

Do not install any fixtures or other protruding parts in this area!

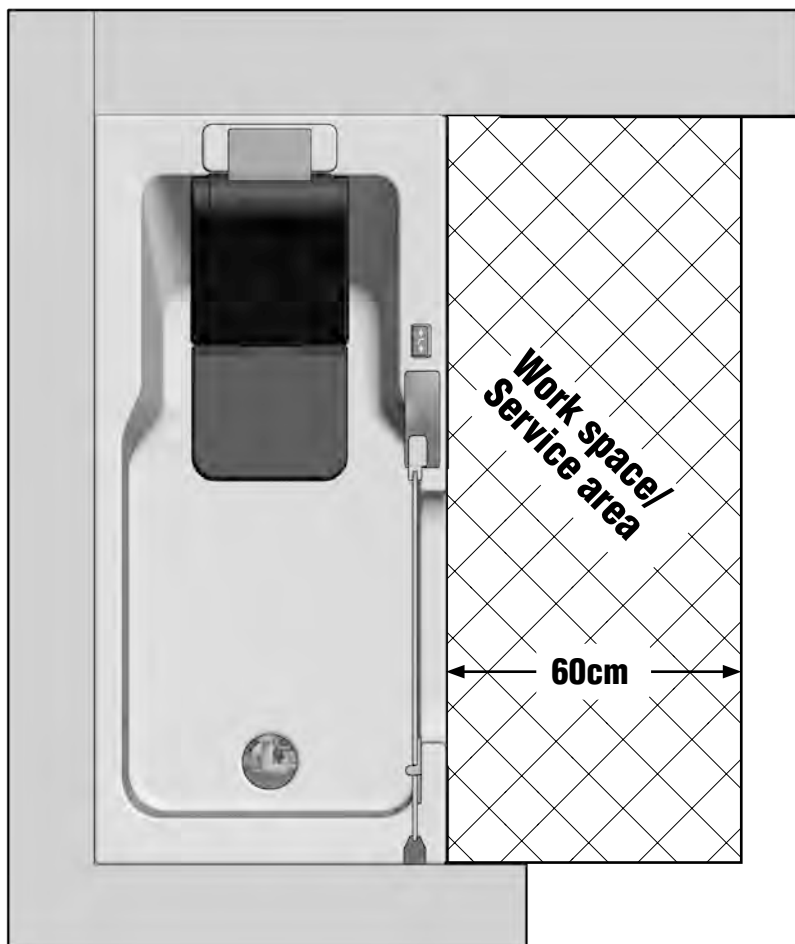
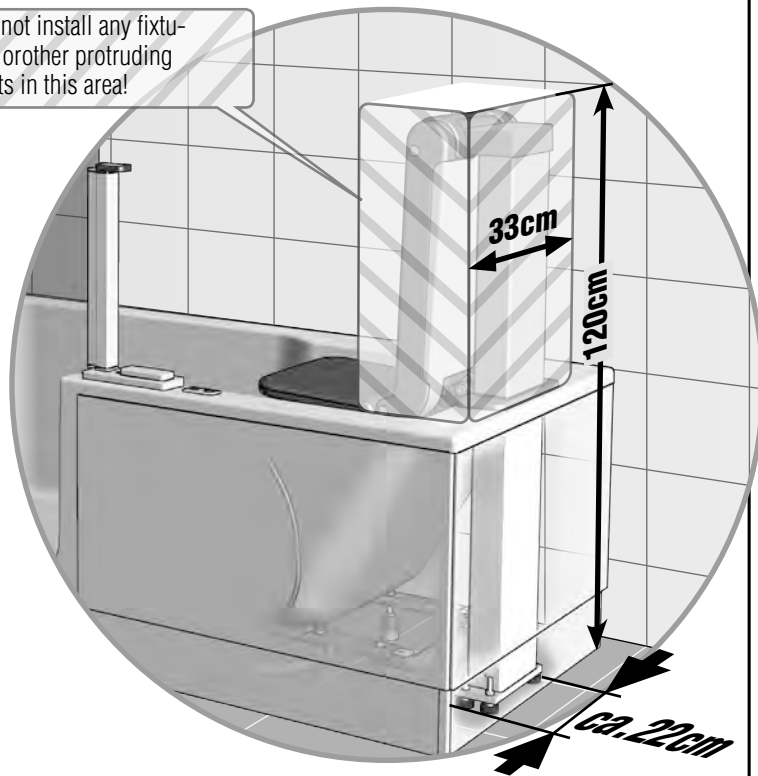



### INSTALLATION - on completed floor

	160/75	170/75	170/80	180/80
<b>k</b>	55	55	60	60

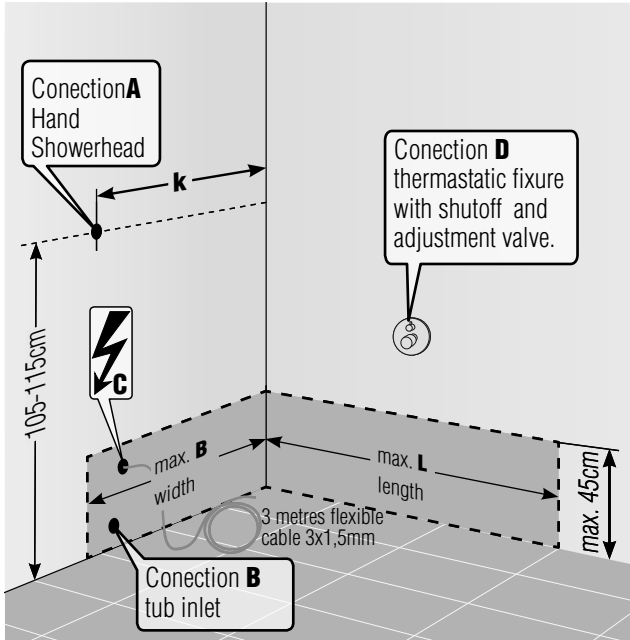

When installing the shower door on the already tiled wall a 1.2 cm compound bracket is required. Do not tile tub **before installation!**

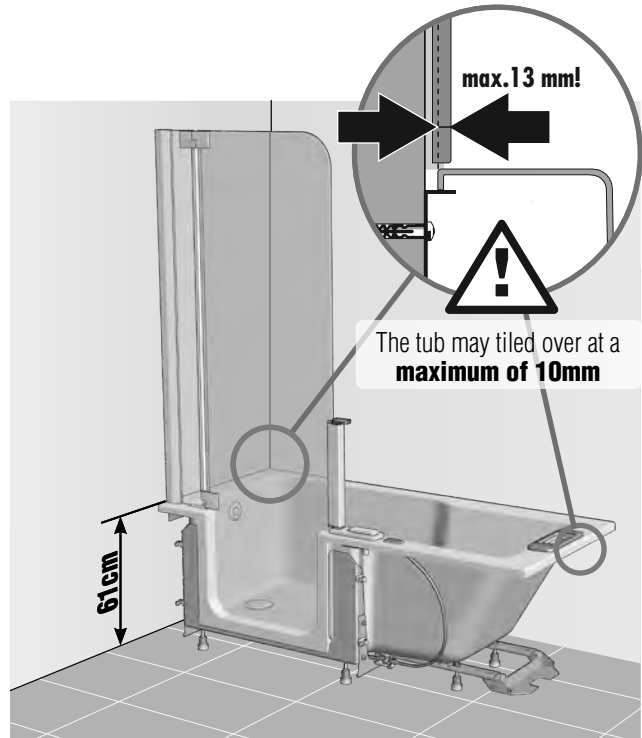

The area **under the tub** must also be **completely tiled!** However, the walls must **not be tiled**

### INSTALLATION ON STRAIGHT WALL - on completed floor

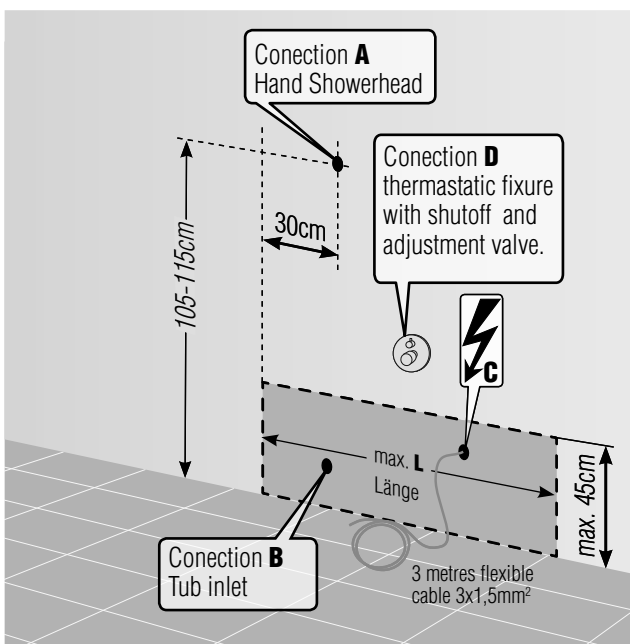

When installing the shower door on the already tiled wall a 1.2 cm compound bracket is required. Do not tile tub **before installation!**

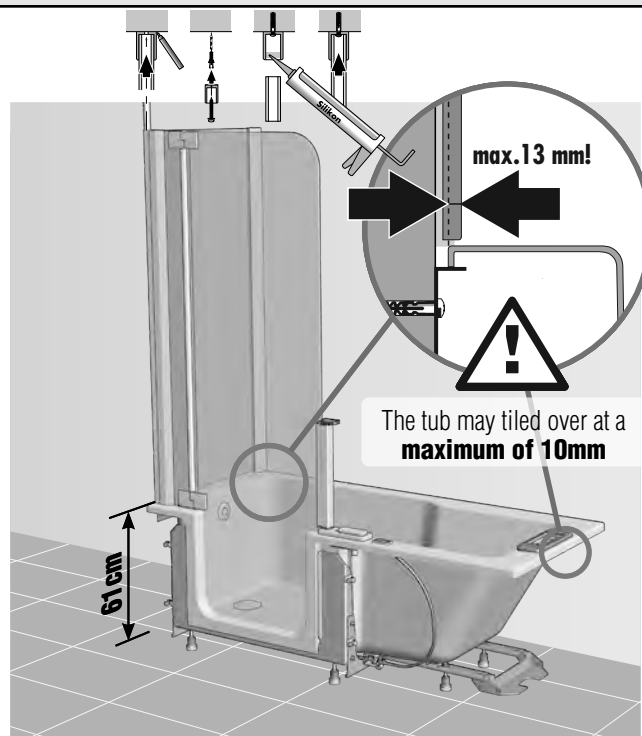

The area **under the tub** must also be **completely tiled!** However, the walls must **not be tiled**

	160/75	170/75	170/80	180/80
<b>B</b>	70	70	75	75
<b>L</b>	155	165	165	175

Water (B) and electrical (C) connections possible only within designated areas!

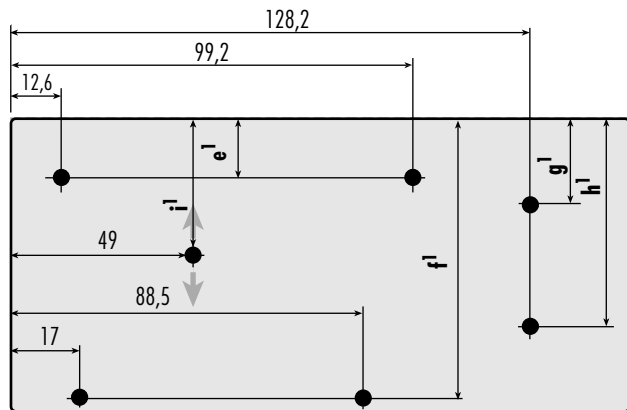
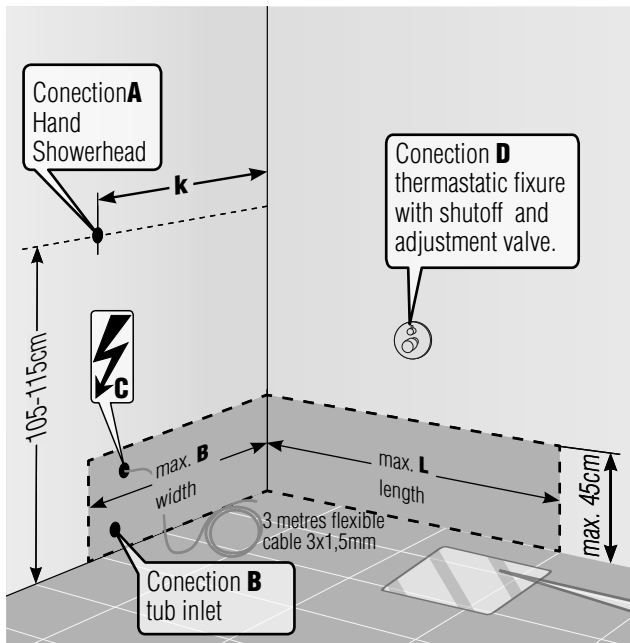

Tub		e'	f'	g'	h'	i'
<b>160x75</b>		14,5	68,7	21,2	51	37,5
<b>170x75</b>		14,5	68,7	21,2	51	37,5
<b>170x80</b>		19,5	93,7	26,2	56	40
<b>180x80</b>		19,5	73,7	26,2	56	40

**Base area of the bath lift is ca. 40cm x 50cm!**  
**Flat area with no pipes!**

Measurements in cm!

## ODOUR-TRAP installation area

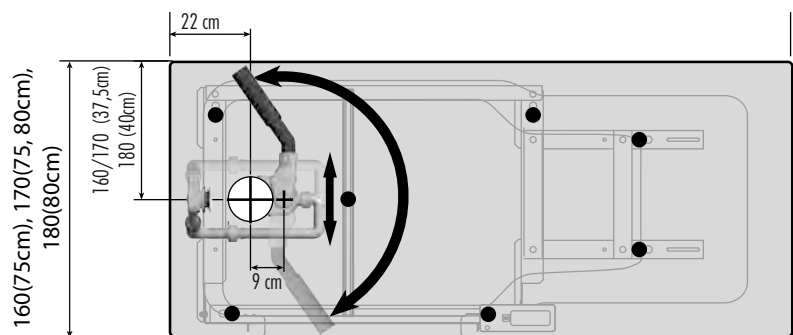

TWINLINE\_2\_Vorinstallation\_DE\_TB/STÖ\_11714\_11\_11

### Height of odour-trap connection

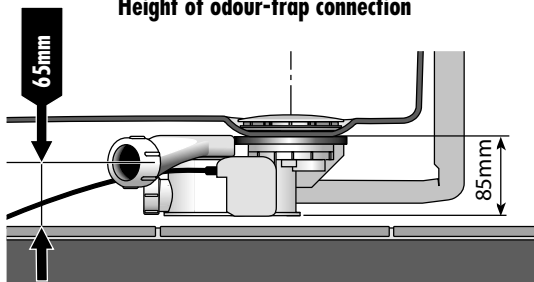

Total height incl. shower screen	211 cm
Room height required	+4,0 cm
Entry height	18,5 cm
Drain	Ø50 mm

### WIRING diagram

Possible combinations	Voltage rating / frequency	max. power
1. Artlift pre-installation set + Artlift AIR	230V ~ 50Hz	50 Watt
2. Artlift + Artlift AIR	230V ~ 50Hz	180 Watt

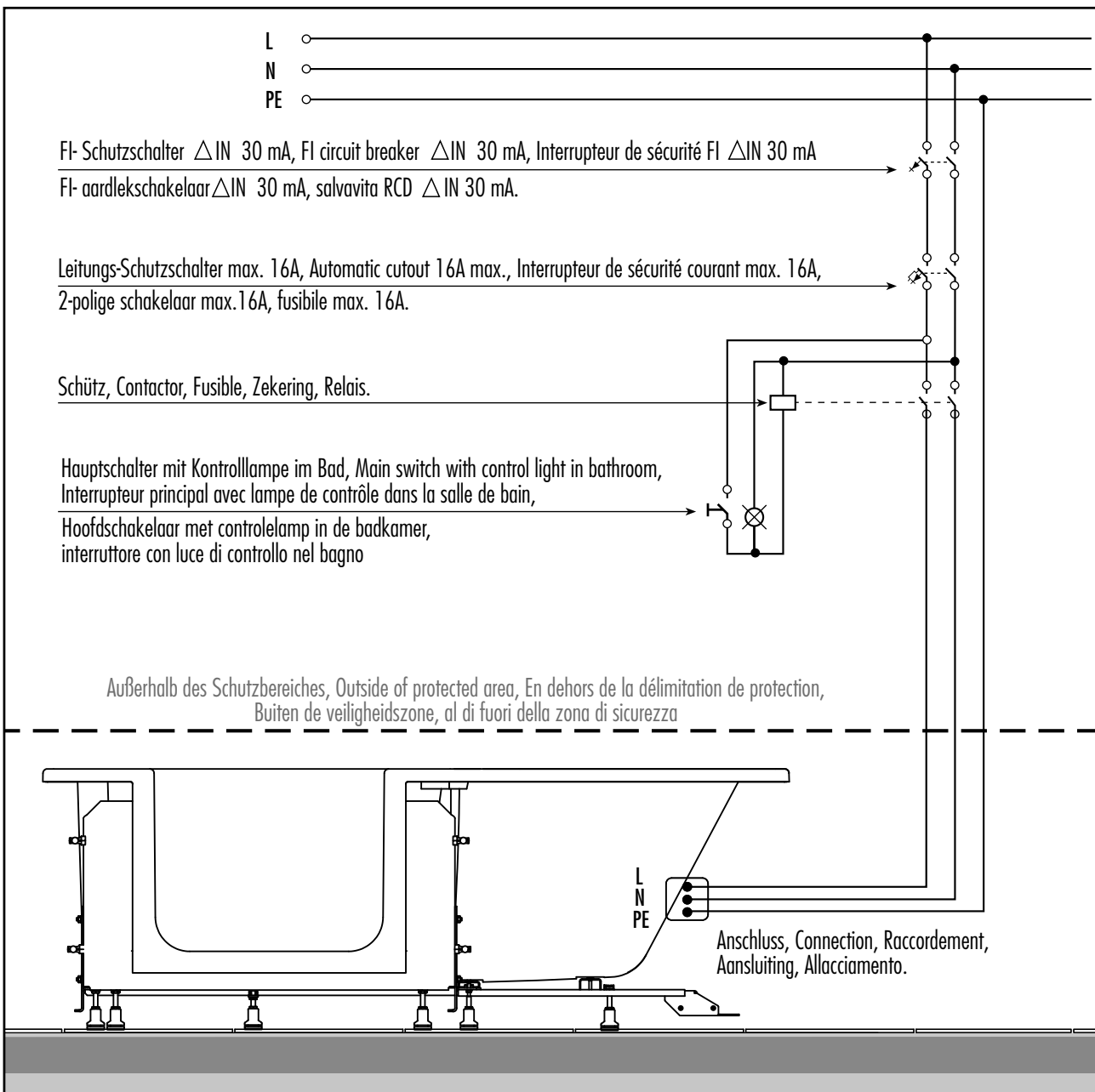

Artweger GmbH. & Co. KG  
Sulzbacherstraße 60 | 4820 Bad Ischl | Austria  
Tel. +43 6132 205-0 | Fax +43 6132 205-5001  
info@artweger.com | www.artweger.com

ARTWEGER UK  
The Sidings  
Thomas Street, Blackpool, FY6 7QQ Lancashire  
Tel: +44 333 666 1260 | Fax: +44 333 666 1261  
infouk@artweger.co.uk | www.artweger.com



Typographical errors and technical changes reserved.