

## MONTAGEANLEITUNG

**2-tlg. Faltwand**, teilgerahmt

**9TKK.52**

**9TKK.58**

## ASSEMBLY INSTRUCTIONS

**Double folding screen**, partially framed

## NOTICE DE MONTAGE

**Paroi pliante avec 2 panneaux**, au cadre réduit

## MONTAGEVOORSCHRIFT

**2dlg. klapwand**, profiel beperkt

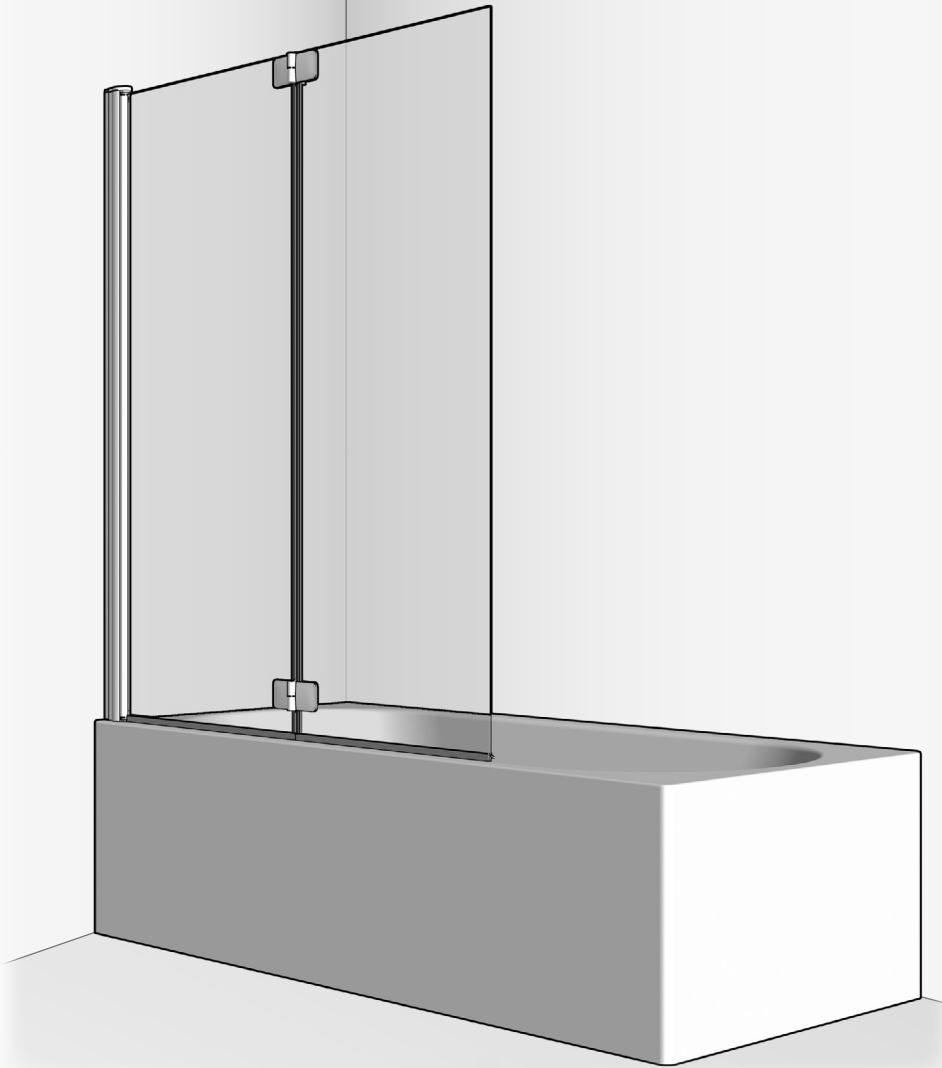

**Vor Gebrauch sorgfältig lesen!** Zum Nachschlagen und Aufbewahren dem Endkunden übergeben!

**Read carefully before use!** Hand over to the customer for looking up and storage!

**Avant emploi lire soigneusement!** Remettez le au client pour la recherche et le stockage!

**Voordien gebruik zorgvuldig lezend!** Overhandig de klant voor het kijken omhooggaand en opslag!

**DEUTSCH**  
Originalsprache

**ENGLISH**  
Translation

**FRANCAIS**  
Traduction

**NEDERLANDS**  
Vertaling

INHALTSVERZEICHNIS	OVERVIEW
<p>INHALTSVERZEICHNIS .....2</p>	<p>OVERVIEW .....2</p>
<p>SICHERHEITS- HINWEISE .....4</p>	<p>SAFETY- INSTRUCTIONS .....4</p>
<p>BENÖTIGTES WERKZEUG .....6</p>	<p>NECESSARY TOOLS .....6</p>
<p>MONTAGESET .....7</p>	<p>ASSEMBLY KIT .....7</p>
<p>MONTAGE .....8</p>	<p>ASSEMBLY .....8</p>
<p>» WANDANSCHLUSS .....9</p>	<p>» INSTALLATION OF IMMOVABLE ELEMENT .....9</p>
<p>» MONTAGE DICHTLEISTEN .....17</p>	<p>» INSTALLATION OF SEALING STRIP .....17</p>
<p>» ABDICHTEN MIT SANITÄRSILIKON .....19</p>	<p>» SEALING WITH SANITARY SILICONE .....19</p>
<p>ERSATZTEILE .....21</p>	<p>SPARE PARTS .....21</p>
<p><b>Montageanleitung für Einbau LINKS -</b> bei Einbau RECHTS - spiegelgleicher Aufbau.</p>	<p><b>Assembly instructions for installation LEFT -</b> for installation RIGHT - assemble in mirror image.</p>

VUE D'ENSEMBLE	OVERZICHT
<p>VUE D'ENSEMBLE .....3</p>	<p>OVERZICHT .....3</p>
<p>INSTRUCTIONS- SÉCURIT.....4</p>	<p>VEILIGHEIDS- VOORSCHRIFTEN .....4</p>
<p>OUTILLAGE NECESSAIRE .....6</p>	<p>BENODIGD GEREEDSCHAP .....6</p>
<p>SET DE MONTAGE.....7</p>	<p>MONTAGESET .....7</p>
<p>MONTAGE .....8</p>	<p>MONTAGE .....8</p>
<p>» MONTAGE PARTIE FIXE .....9</p>	<p>» MONTAGE VAST DEEL .....9</p>
<p>» MONTAGE BAGUETTES D'ÉTANCHÉITÉ .....17</p>	<p>» MONTAGE AFDICHTINGEN .....17</p>
<p>» ETANCHER AVEC DU SILICONE SANITAIRE.....19</p>	<p>» AFDICHTEN MET SANITAIR-SILICONEN.....19</p>
<p>PIÈCES DÉTACHÉES .....21</p>	<p>ONDERDELEN .....21</p>
<p><b>C'est prévue pour une installation à GAUCHE –</b> en cas d'une installation à DROITE -A inverser pour partie fixe en GAUCHE.</p>	<p><b>Montagevoorschrift voor inbouw LINKS -</b> bij inbouw RECHTS - montage in spiegelbeeld.</p>

**SICHERHEITS-  
HINWEISE**

**SAFETY-  
INSTRUCTIONS**

**INSTRUCTIONS-  
SÉCURITÉ**

**VEILIGHEIDS-  
VOORSCHRIFTEN**

**DE Vor dem Einbau bitte unbedingt beachten!**

- Produkt **vor dem Einbau**, auf Richtigkeit, Beschädigungen und das Zubehör auf Vollständigkeit **überprüfen**.
- **Bei sichtbarem Schaden Produkt keinesfalls einbauen!**
- **Beachten Sie beim Hantieren das teilweise hohe Gewicht und/oder die großen Abmessungen von Einzelteilen.**
- **Beachten Sie beim Bohren der Löcher, dass Sie keine Leitungen (Elektro, Gas, Wasser) beschädigen.**



Unsere Haftung beschränkt sich alleine auf unsere Produkte und kann daher nicht auf den Ein- und Ausbau ausgedehnt werden. Die Kosten für einen nachträglichen Aus- und Einbau eines Produkts und die damit verursachten Schäden sind **kein** Bestandteil der Garantie.

**EN Please note carefully before installing**

- Before installing, check for correctness and damage and the accessories for completeness.
- **Do not under any circumstances install product with visible damage!**
- **Take the great weight and/or the large dimensions into consideration when handling individual parts!**
- **When drilling holes do not damage hidden pipes and wiring.**

Our liability is limited to our products alone and therefore cannot be extended to installation and dismantling. Costs for subsequent dismantling and installation of a product and damage caused thereby are not part of the guarantee.

**FR A respecter impérativement avant le Montage**

- Avant le montage de vérifier qu'il s'agit du bon modèle, qu'elle n'est pas endommagée et que les accessoires sont complets.
- **En cas de dommages visibles, ne pas monter le produit!**
- **Lors de la manutention, merci de prêter attention au poids parfois très élevé et/ou aux dimensions de certaines pièces!**
- **Faites attention en perçant les trous de ne pas endommager les tuyauteries (cables électriques, canalisations de gaz, d'eau, etc).**

Notre responsabilité se limite à nos produits et ne peut être étendue sur l'installation et le démontage. Les coûts générés lors d'un démontage après installation et d'une ré-installation d'un produit et les dommages qui en résultent ne pourront être pris en charge par la garantie.

**NL Voor inbouw beslist in acht nemen!**

- Bad voor het inbouwen op juistheid, beschadigingen en toebehoren op volledigheid controleren.
- **Bij zichtbare beschadiging product in geen geval inbouwen!**
- **Let u bij het gebruik om het gedeeltelijk grote gewicht en/of de grote afmetingen van enkele onderdelen!**
- **bij het boren van gaten er op letten, dat U geen leidingen (elektro, gas of water) beschadigt!**

Wanneer het bad betegeld wordt, beslist de inbouwmaten van de badkuip en van de doucheafdeling in acht nemen. Onze aansprakelijkheid is beperkt tot onze producten en kan daarom niet op de in- en uitbouw uitgebreid worden. De kosten voor een latere uit- en inbouw van een product en de daaruit voortvloeiende schade zijn geen onderdeel van de garantie.

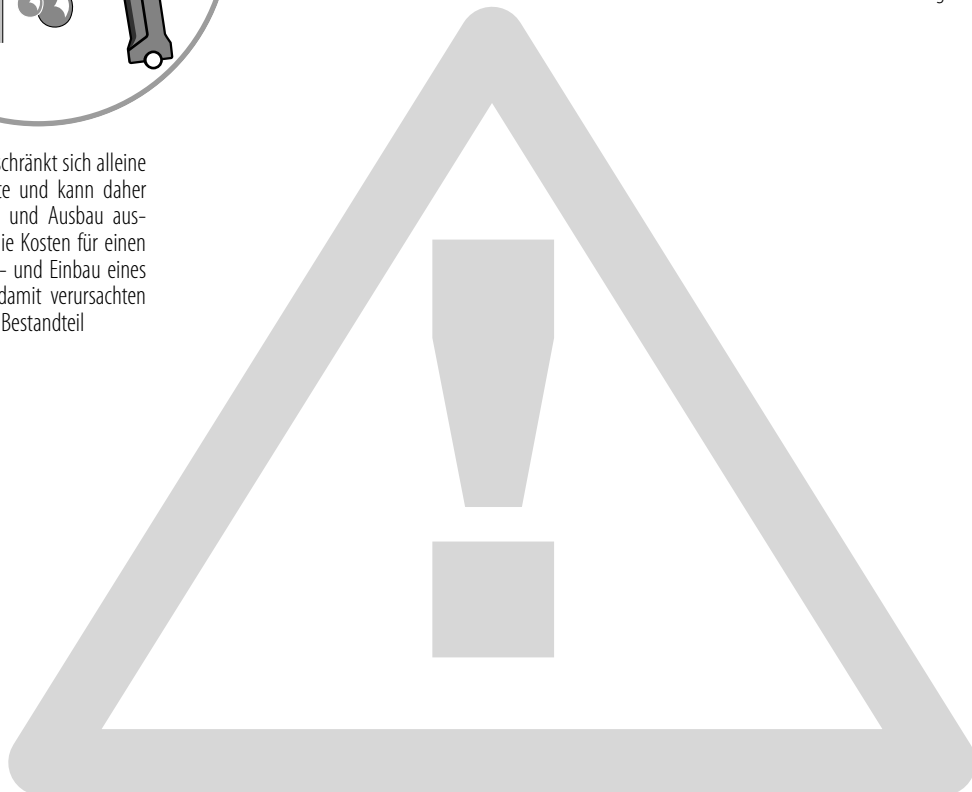



**DE ACHTUNG!**  
**Beim Hantieren**  
**mit Glas Schutz-**  
**kleidung tragen!**

Bitte untersuchen Sie nach dem Auspacken das Einscheiben-Sicherheitsglas (ESG) unverzüglich auf mögliche Transportschäden, wie abgesprungene Kanten oder Ecken. Wird ein Schaden festgestellt bitte umgehend Schadensmeldung machen und die Scheibe nicht einbauen, da dieser Fehler auch später zu einem Bruch führen kann! Alle Gläser werden vor dem Verpacken sorgfältig kontrolliert. Spätere Reklamationen, auch bei Bruch, können daher nicht anerkannt werden.

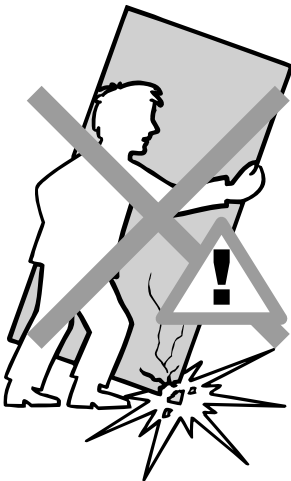

**EN ATTENTION!**  
**Wear protective**  
**clothing when**  
**handling glass!**

Please examine the single-pane safety glass for possible transport damage such as chipped edges or corners immediately after unpacking. If damage is detected do not install the pane because a defect can lead to breakage later! Please make a damage report without delay! All glass panes are controlled with utmost care before packing. Therefore later complaints cannot be acknowledged, even in case of breakage.

**FR ATTENTION !**  
**Portez des**  
**vêtements**  
**protecteurs en**  
**manipulant du**  
**verre.**

Merci de vérifier immédiatement le verre de sécurité monofeuille au déballage sur d'éventuels dommages survenus au transport, tels que chants et angles écaillés. Si toutefois un défaut a été constaté, merci d'en faire la déclaration au plus vite et ne pas monter la vitre, car ce défaut peut être, par la suite, à

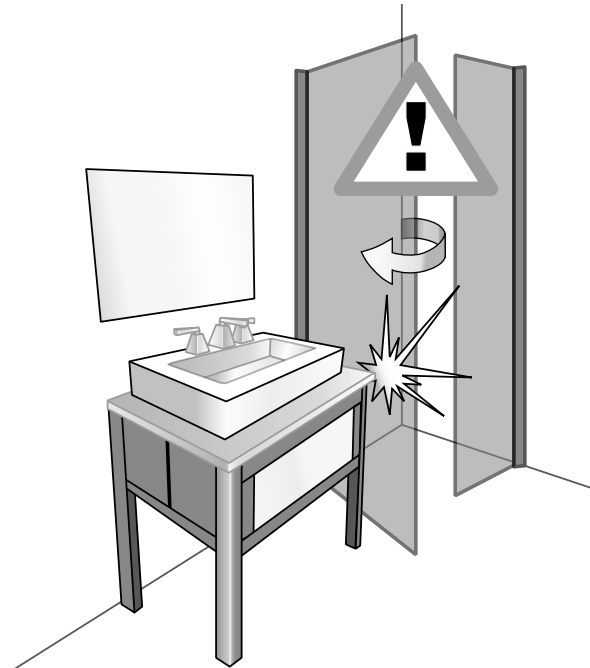

l'origine d'une casse! Tous les verres sont contrôlés minutieusement avant le conditionnement. Pour cette raison, aucune réclamation ultérieure, même en cas de casse, ne pourra être prise en compte.

Na het uitpakken het enkel veiligheidsglas (ESG) onmiddellijk op mogelijke transport- beschadigingen, zoals afgesprongen kanten of hoeken, controleren. Wordt een beschadiging vastgesteld, dan mag het glas niet worden ingebouwd, omdat deze schade ook later tot een breuk kan leiden !Bij een vastgestelde schade, meldt dit onmiddellijk! Al het glas wordt voor het verpakken zorgvuldig gecontroleerd. Latere reclames, ook bij breuk, kunnen daarom niet geaccepteerd worden.

**NL ATTENTIE !**  
**Bij het hanteren**  
**van glas be-**  
**schermde kle-**  
**ding dragen!**

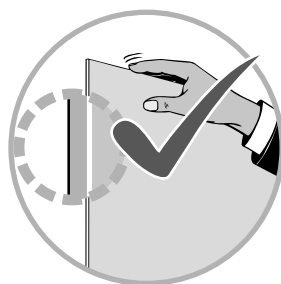
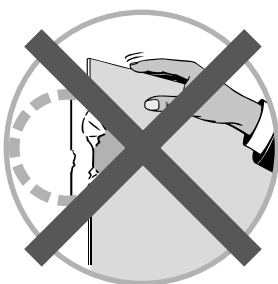









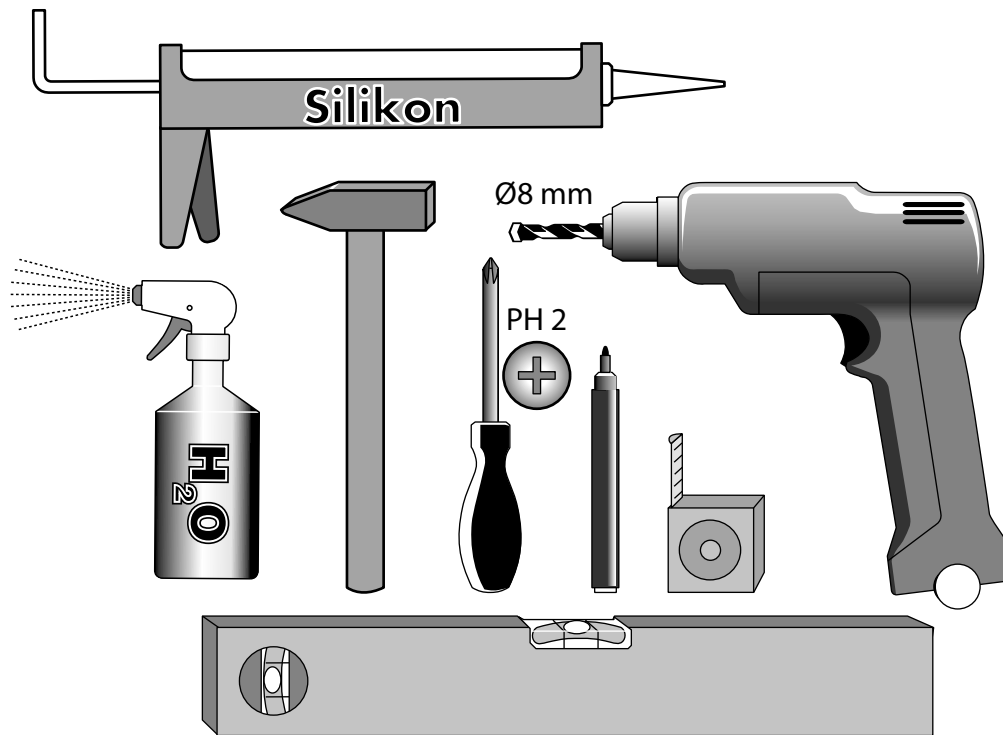

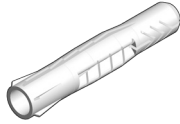

**BENÖTIGTES  
WERKZEUG**

**NECESSARY  
TOOLS**

**OUTILLAGE  
NECESSAIRE**

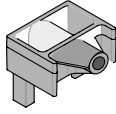
**BENODIGD  
GEREEDSCHAP**

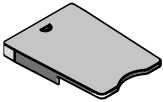
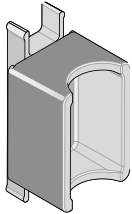
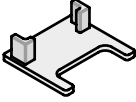

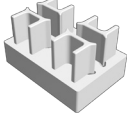
MONTAGESET	ASSEMBLY KIT	SET DE MONTAGE	MONTAGESET
<p><b>5x</b> 4,8 x 60mm MatNr: 2477</p> 	<p><b>4x</b> DIN 9021-M5-A2 MatNr: 2494</p> 	<p><b>4x</b> Ø 8 x 50 mm MatNr: 24409</p> 	<p><b>3x</b> 3,5 x 25mm MatNr: 2418</p> 
<p><b>1x</b> Ø3 mm MatNr: 18750</p> 		<p><b>5x</b> 3,5 x 13 mm MatNr: 2429</p> 	<p><b>5x</b> MatNr: 18852 VC</p> 
<p><b>1x</b> MatNr: 705376 2</p> 	<p><b>1x</b> MatNr: 705376 1</p> 	<p><b>1x</b> MatNr: 704209 DG</p> 	<p><b>1x</b> MatNr: 704210 DG</p> 
<p><b>1x</b> MatNr: 18926 VC</p> 	<p><b>1x</b> MatNr: 704207</p> 	<p><b>4x</b> MatNr: 704208</p> 	<p><b>1x</b> MatNr: 704205</p> 
<p><b>2x</b> MatNr: 705706</p> 	<p><b>1x</b> MatNr: 809T39</p> 		

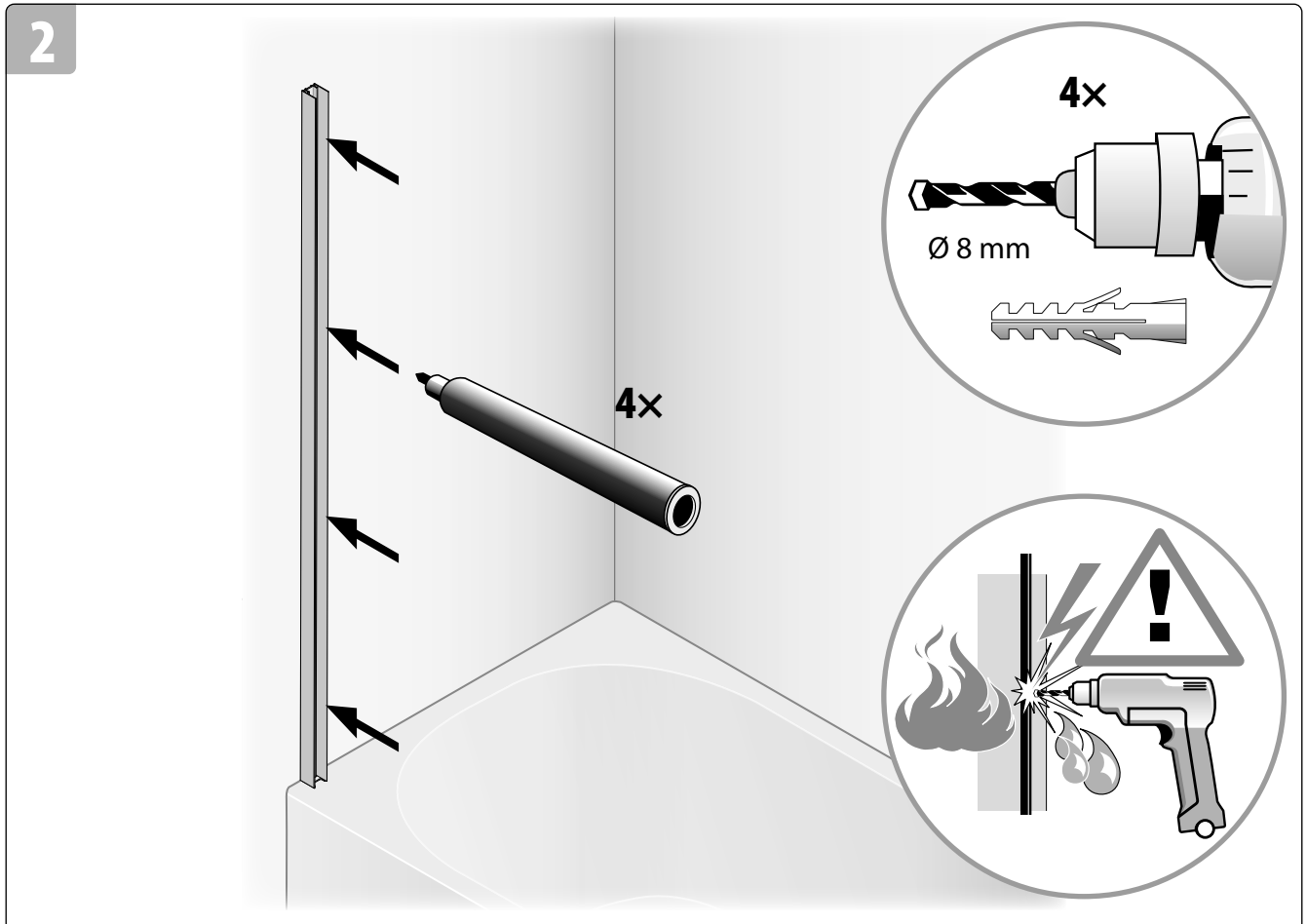
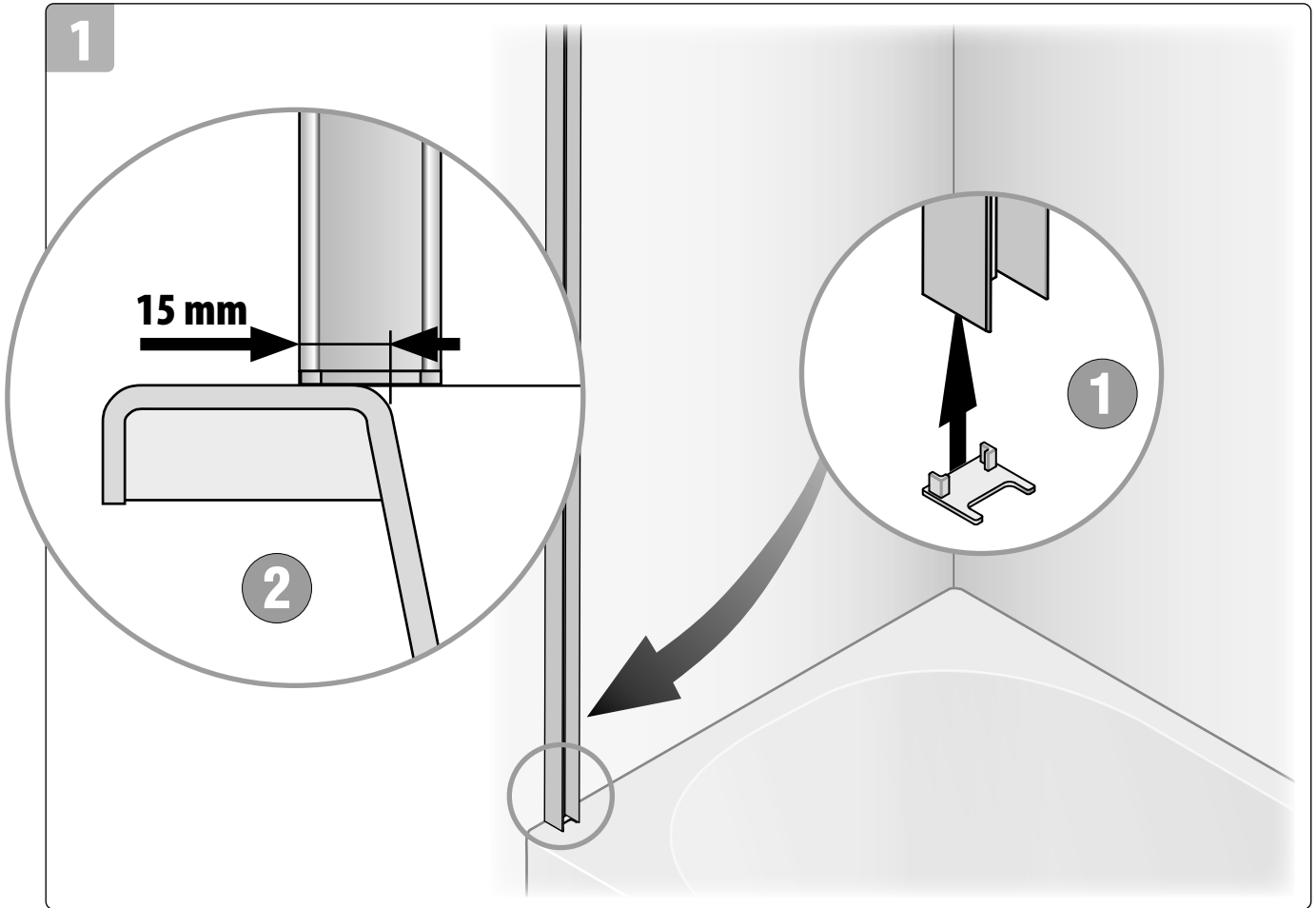



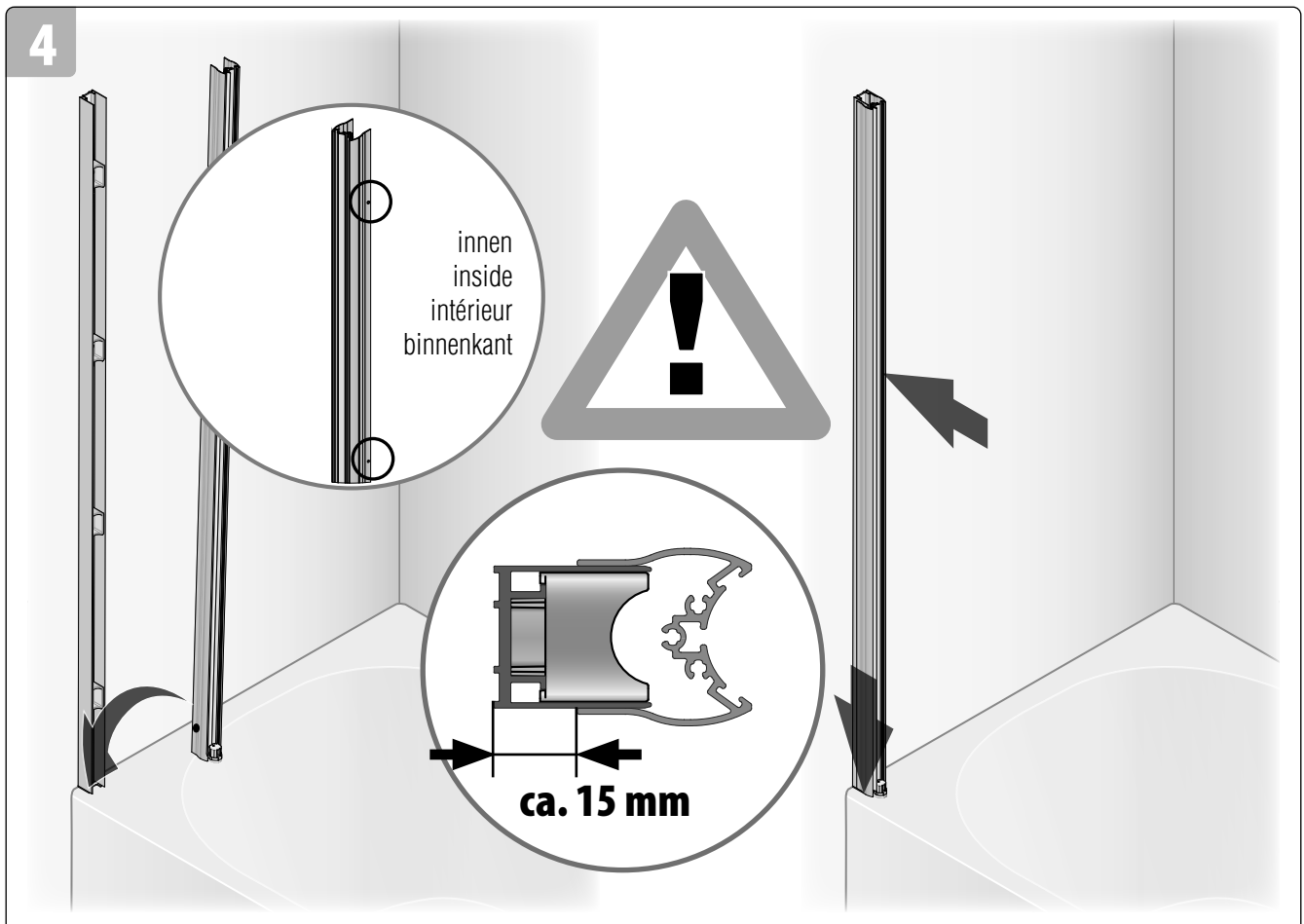
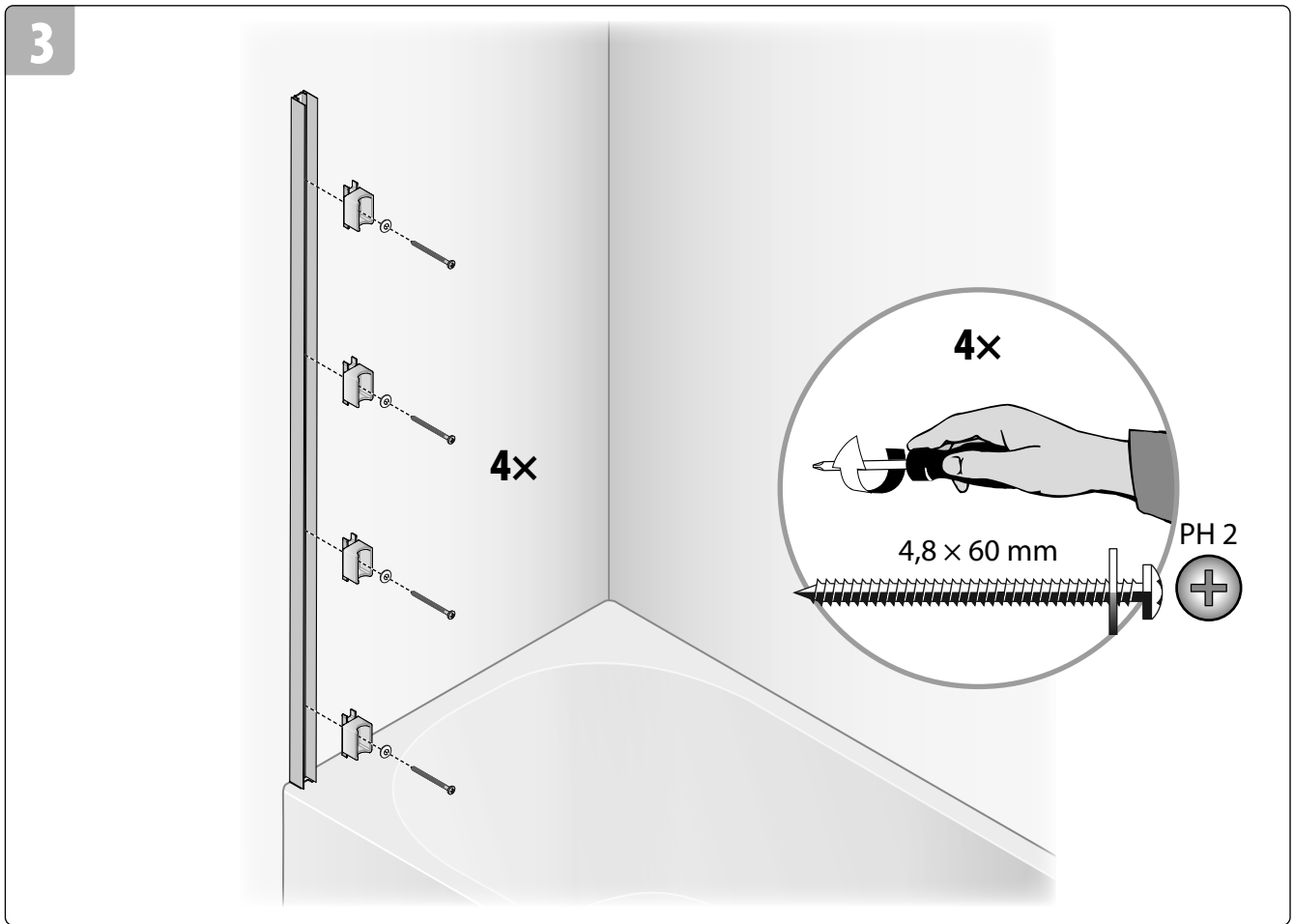

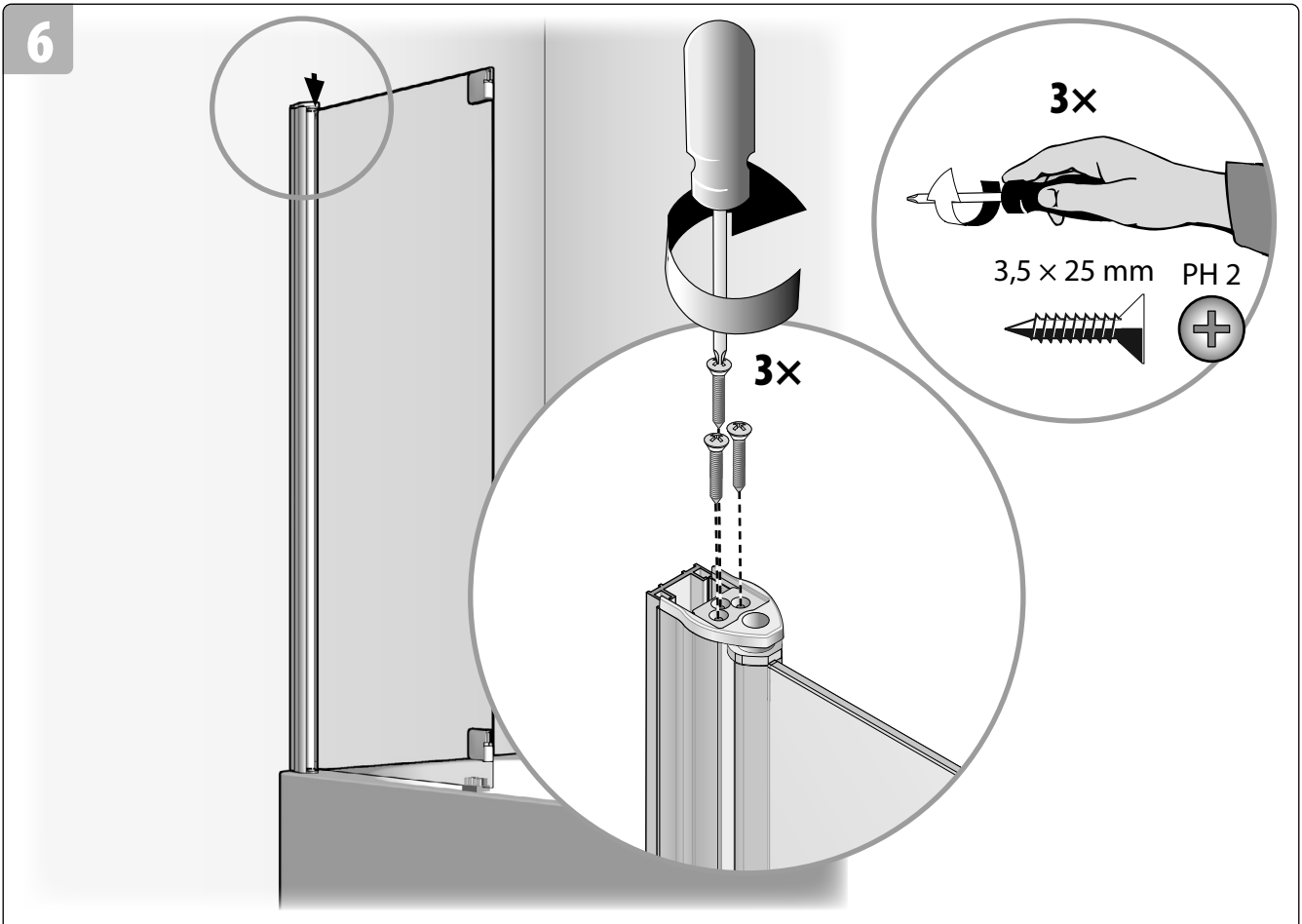
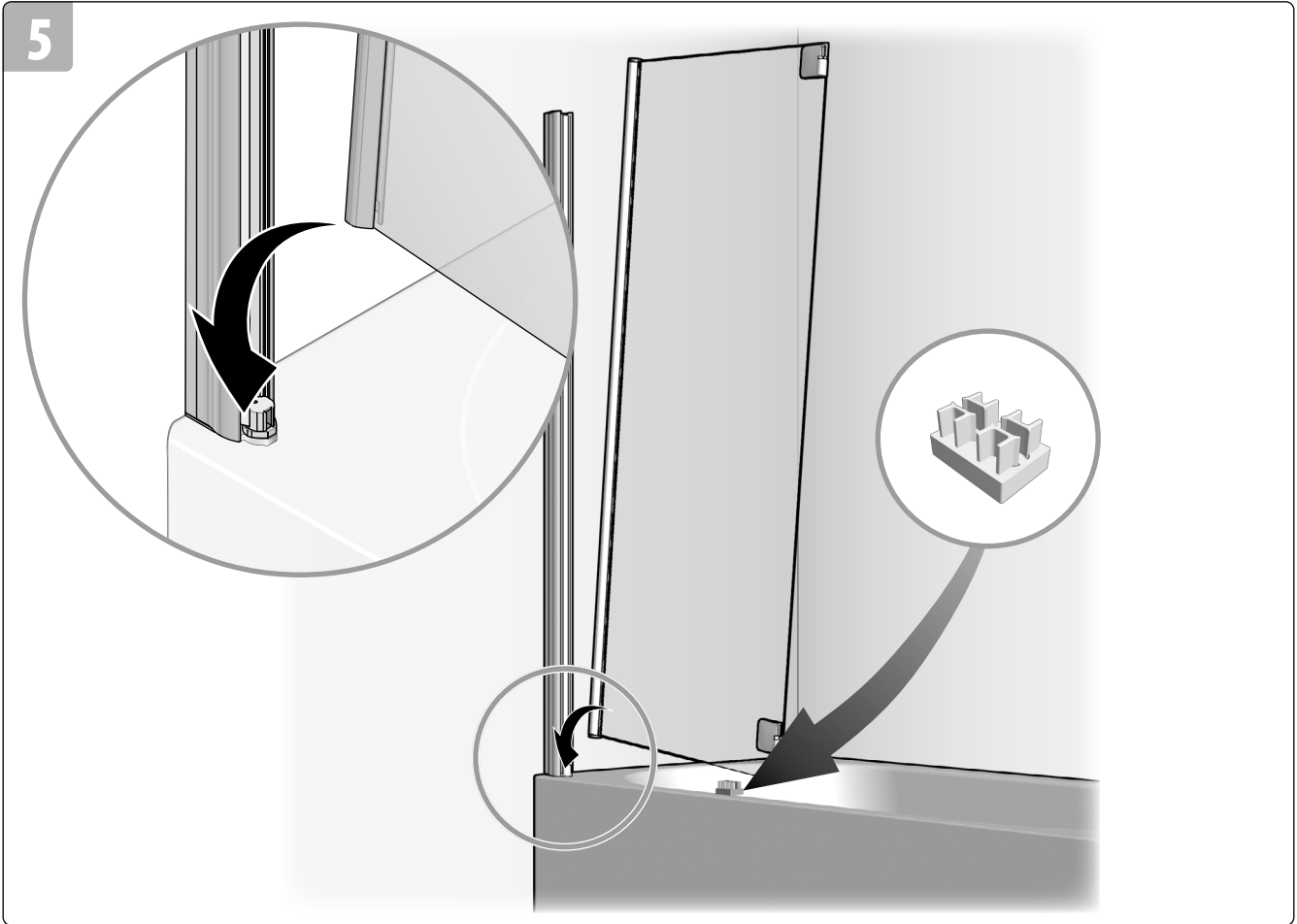

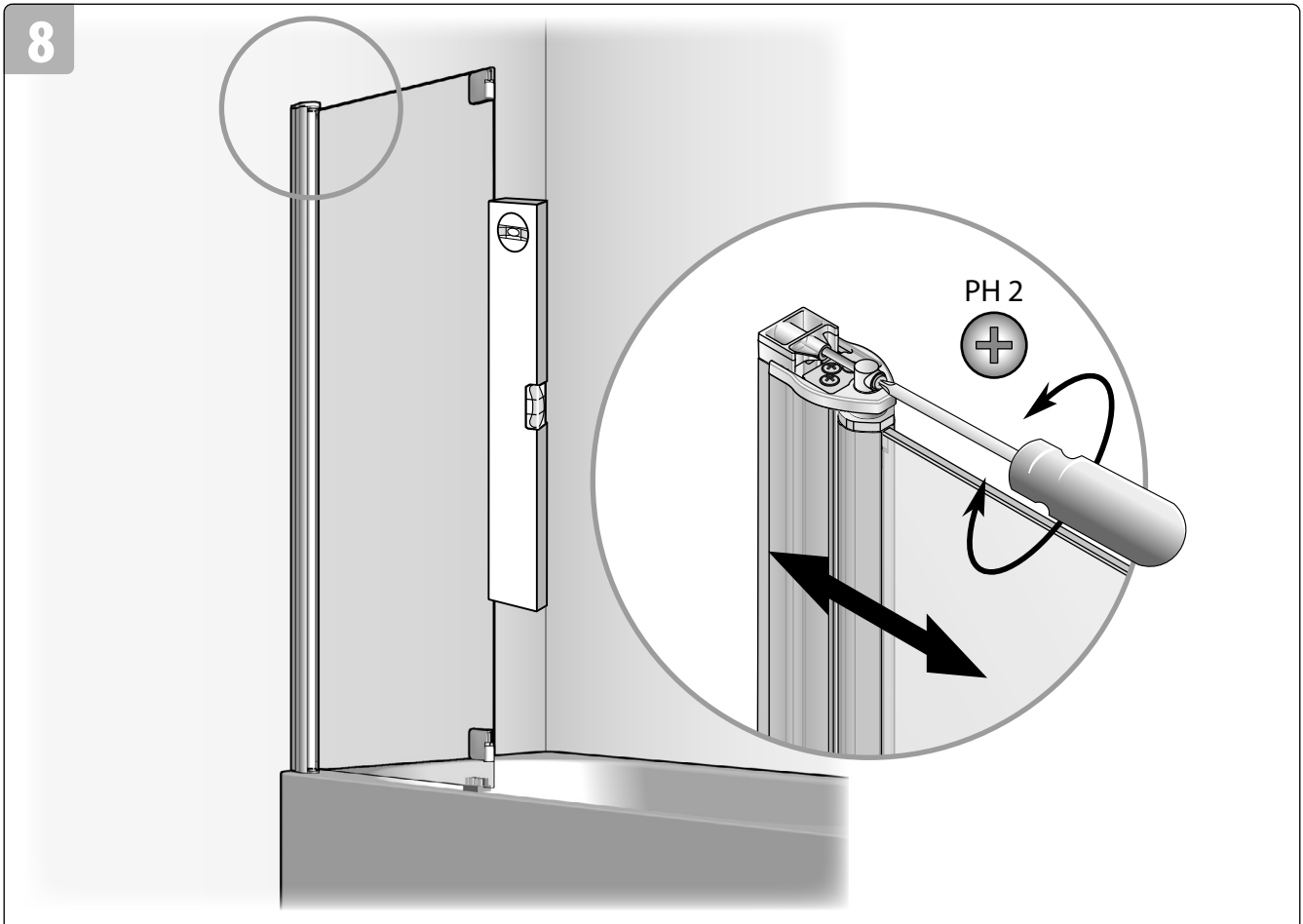
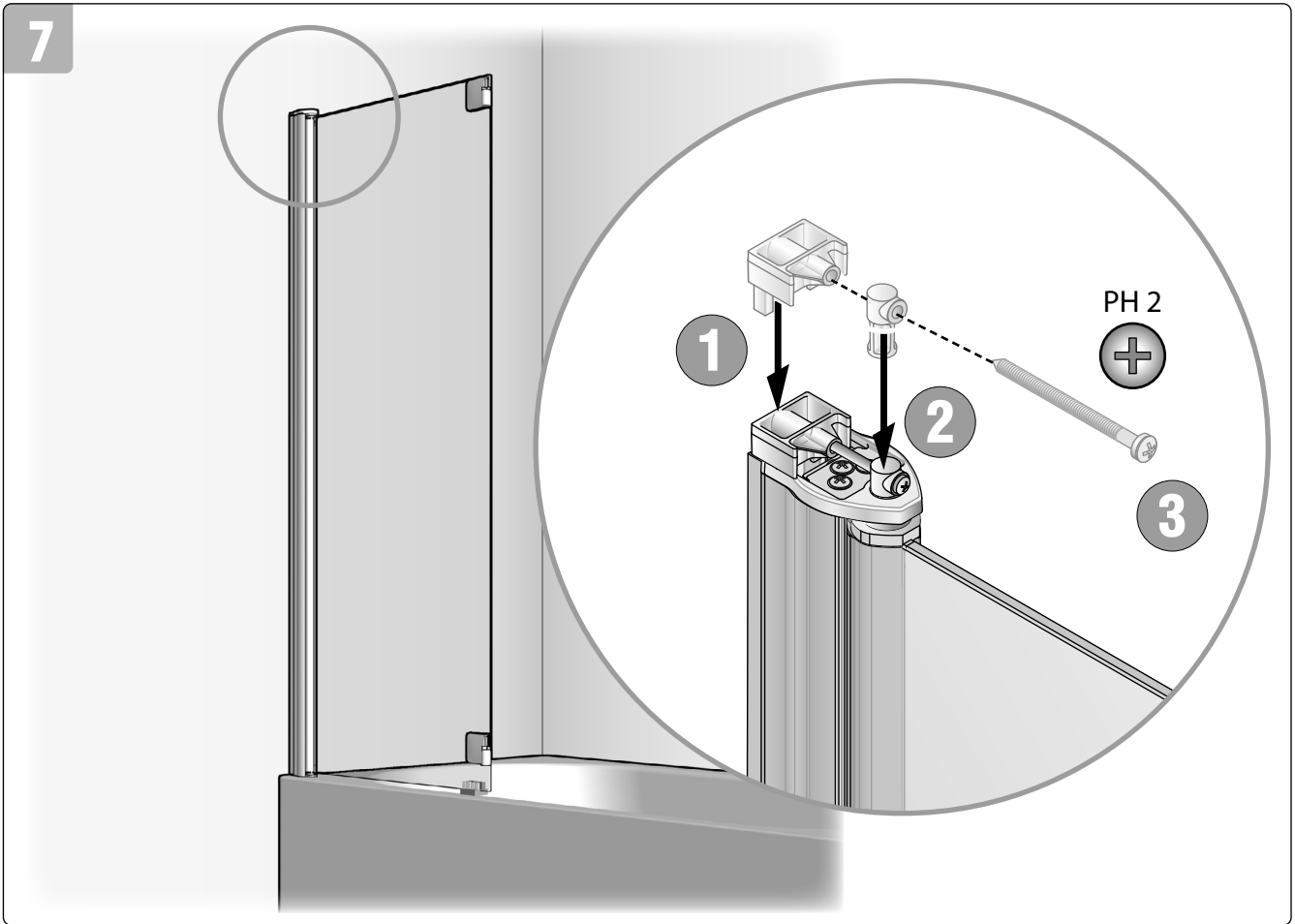

9

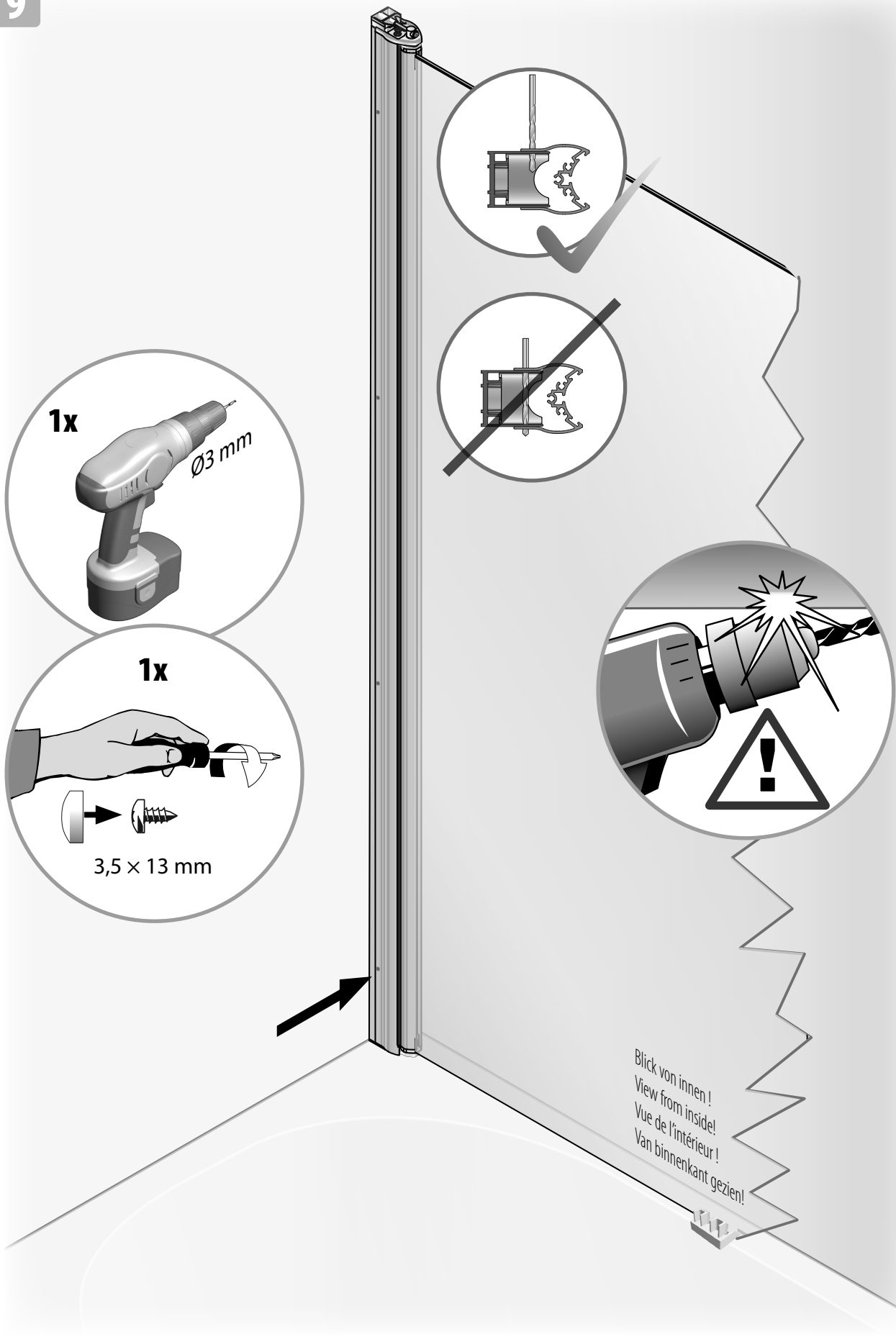

**10**

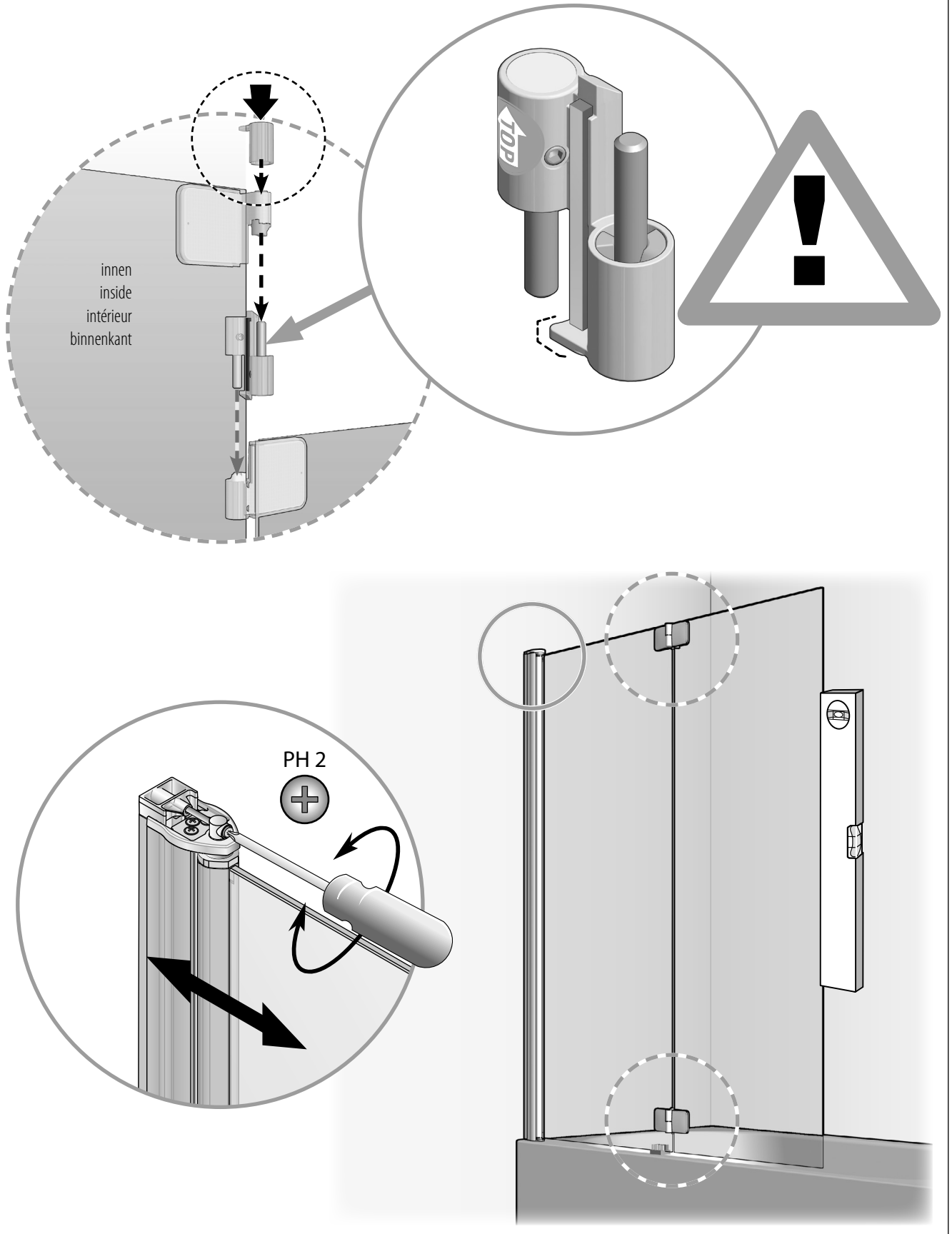

11

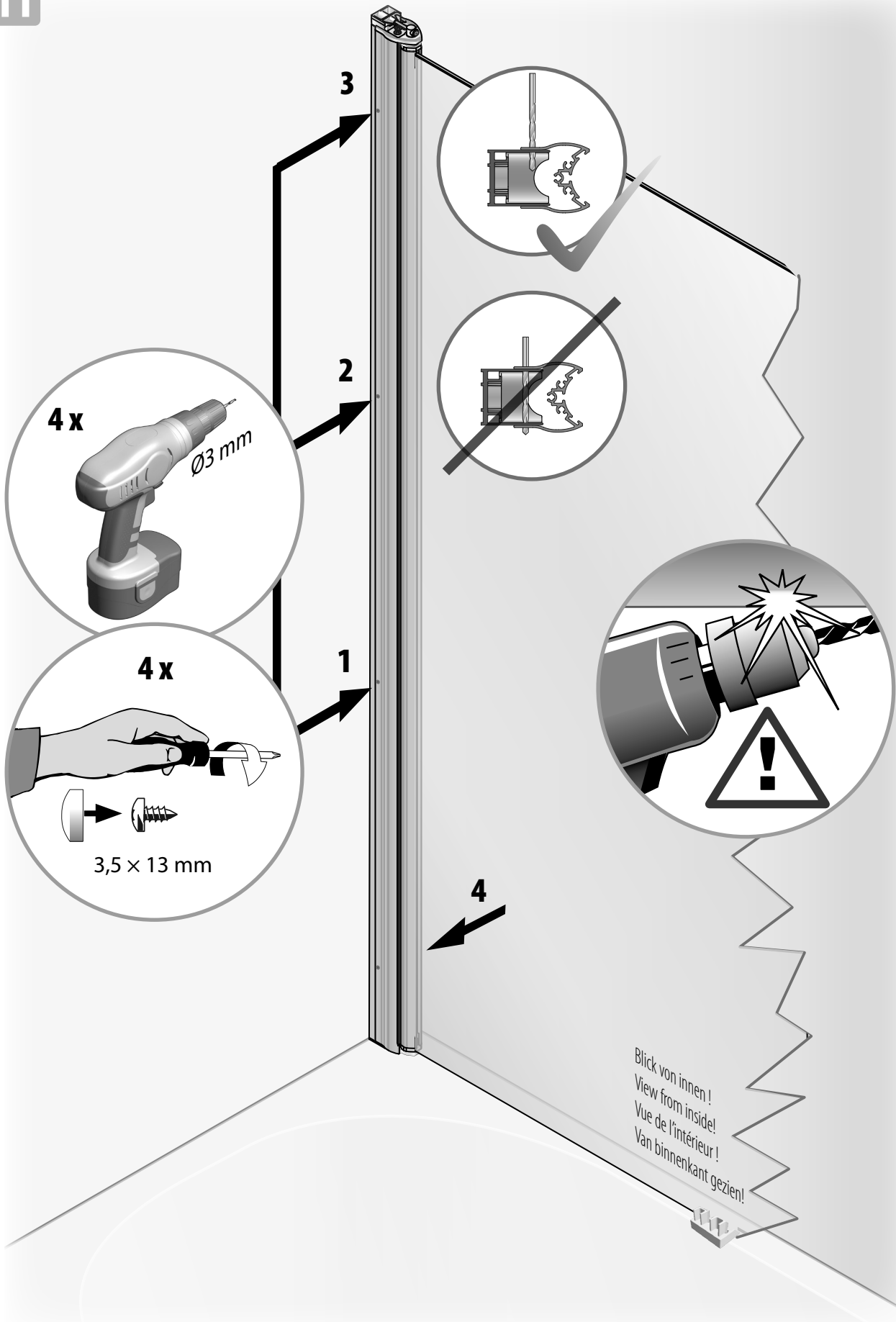

**12**

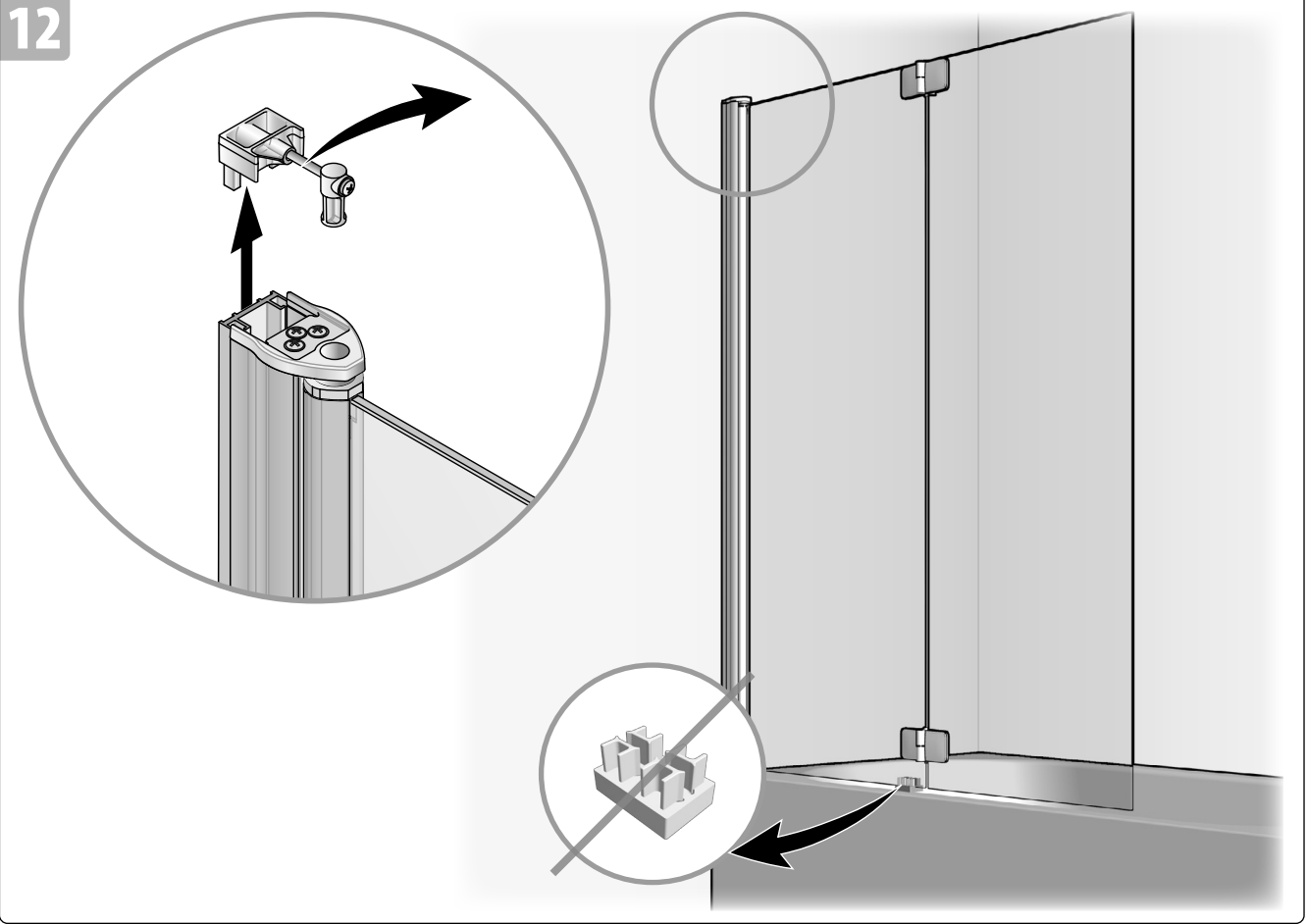

**13**

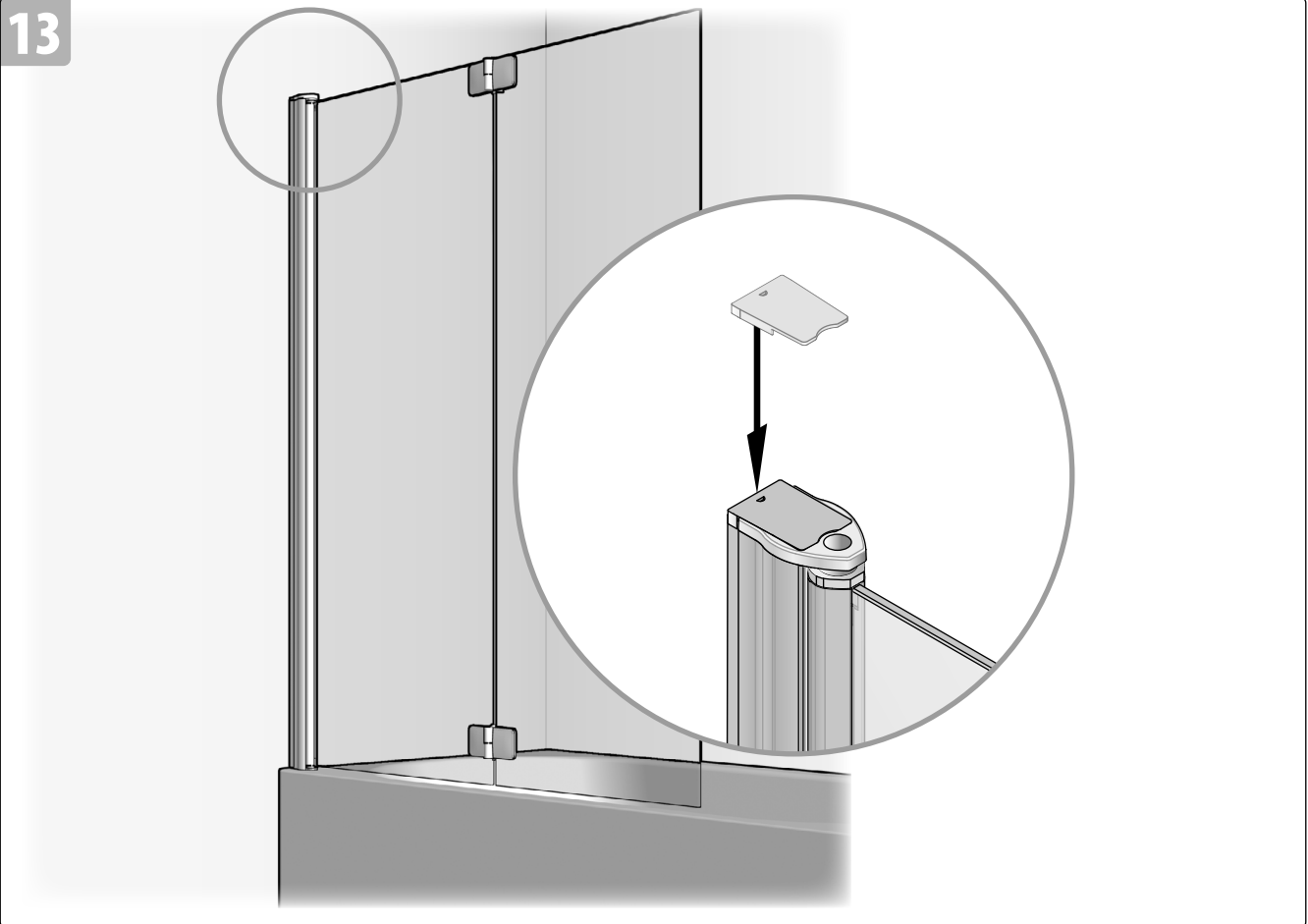

**14**

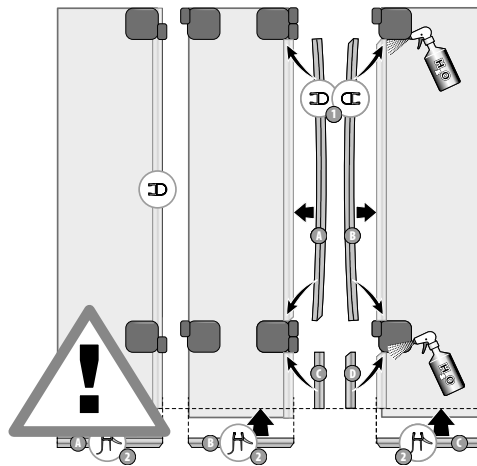

**1**

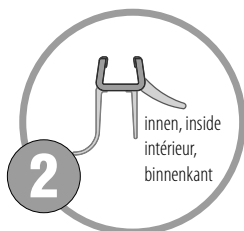
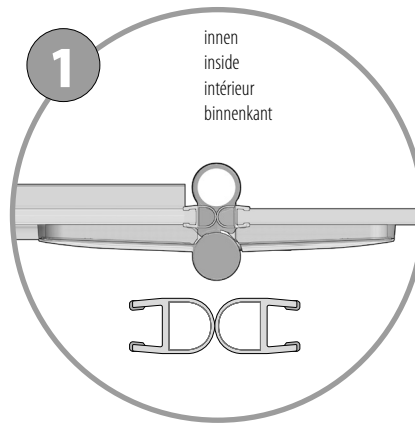



15

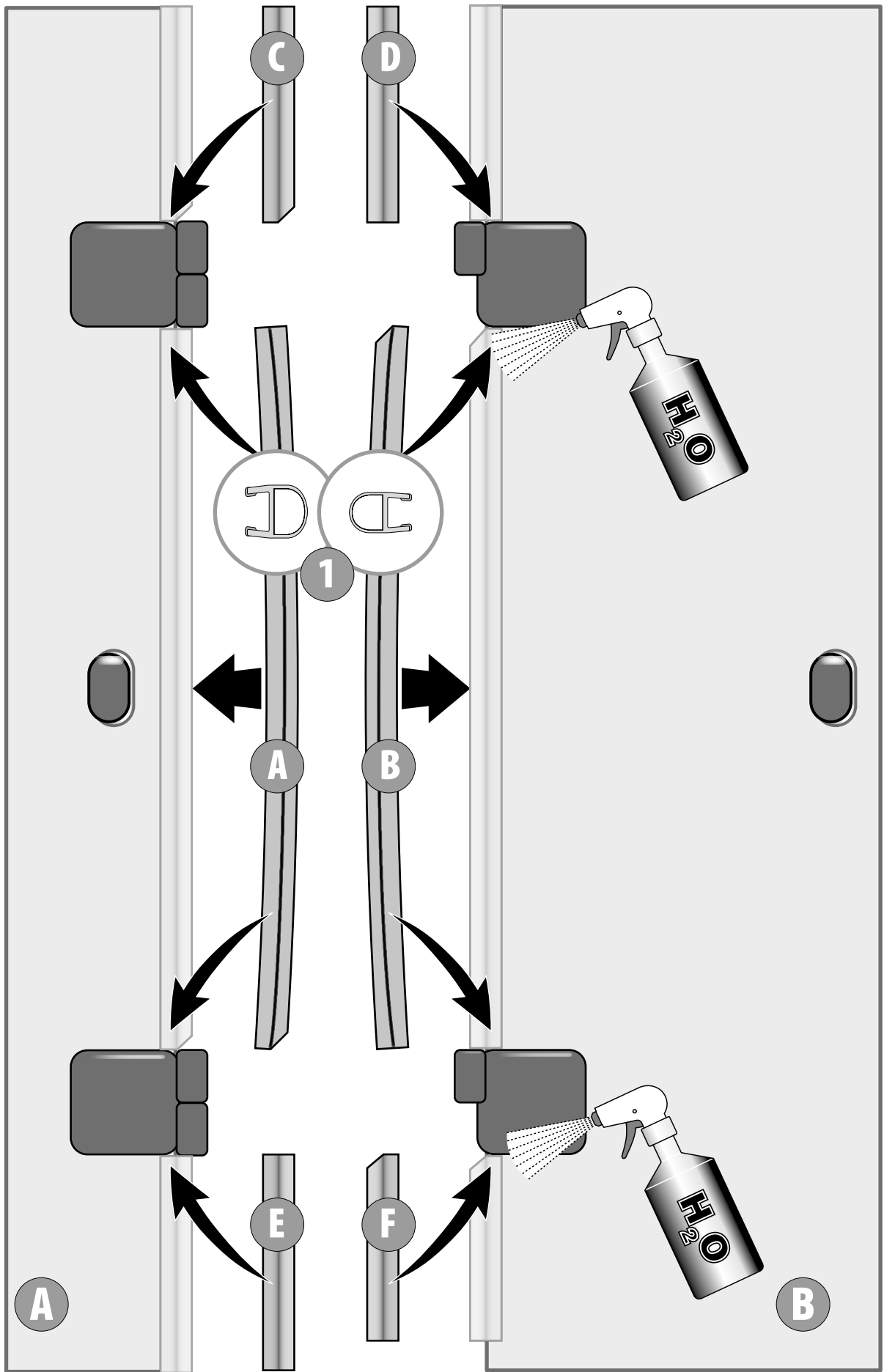

16

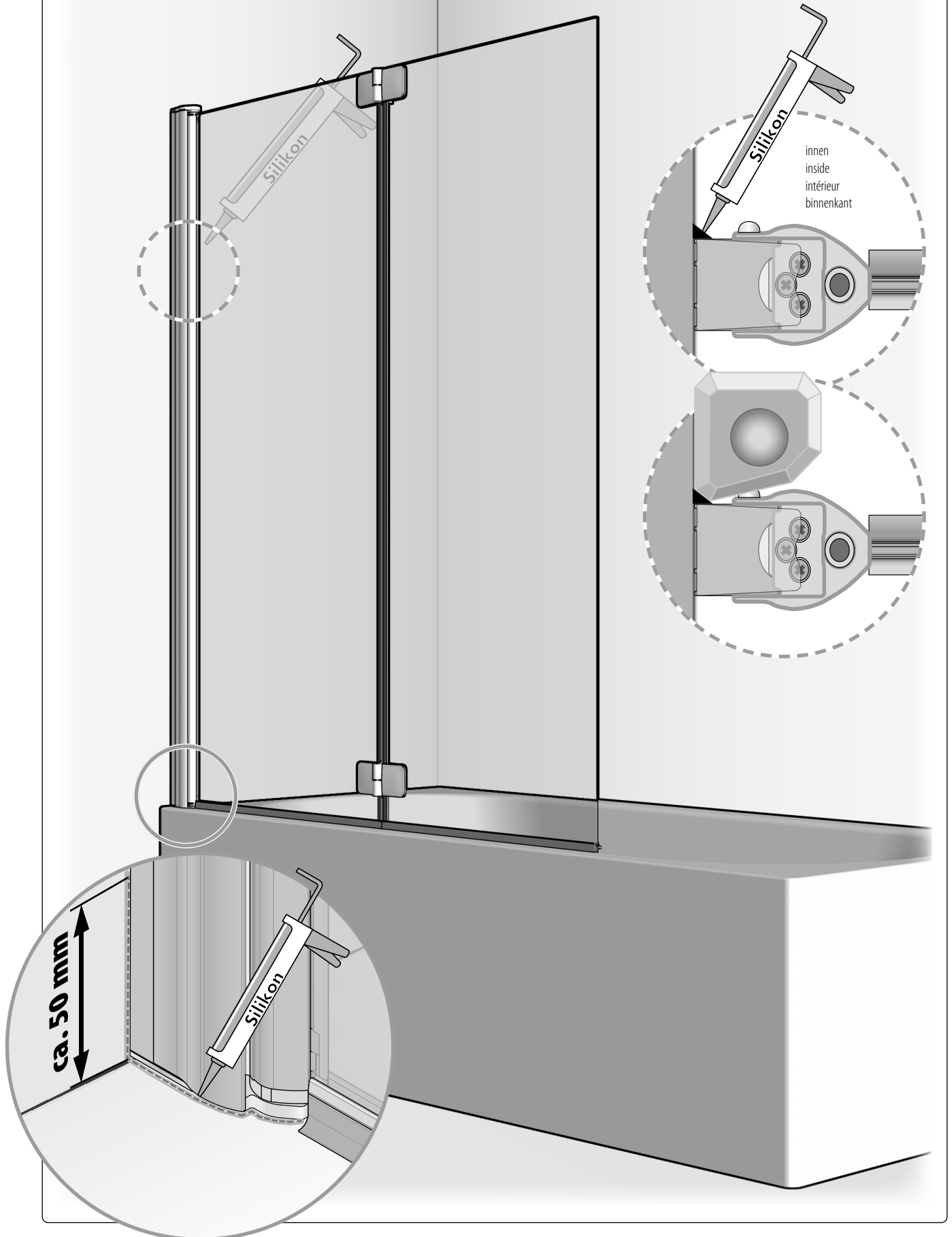

17

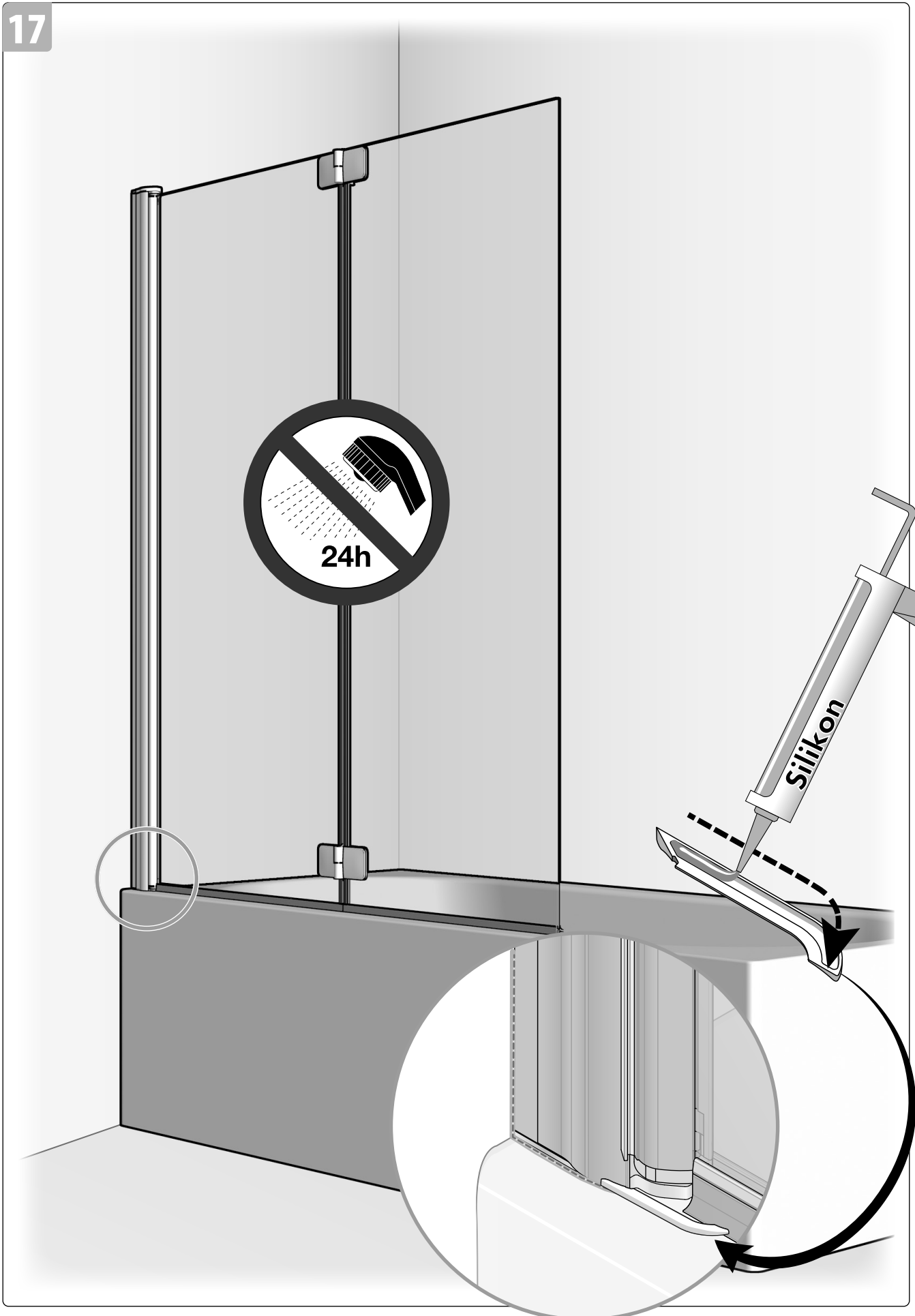







# ARTWEGER 360 TEILGERAHMT

## 2-tlg. Faltwand

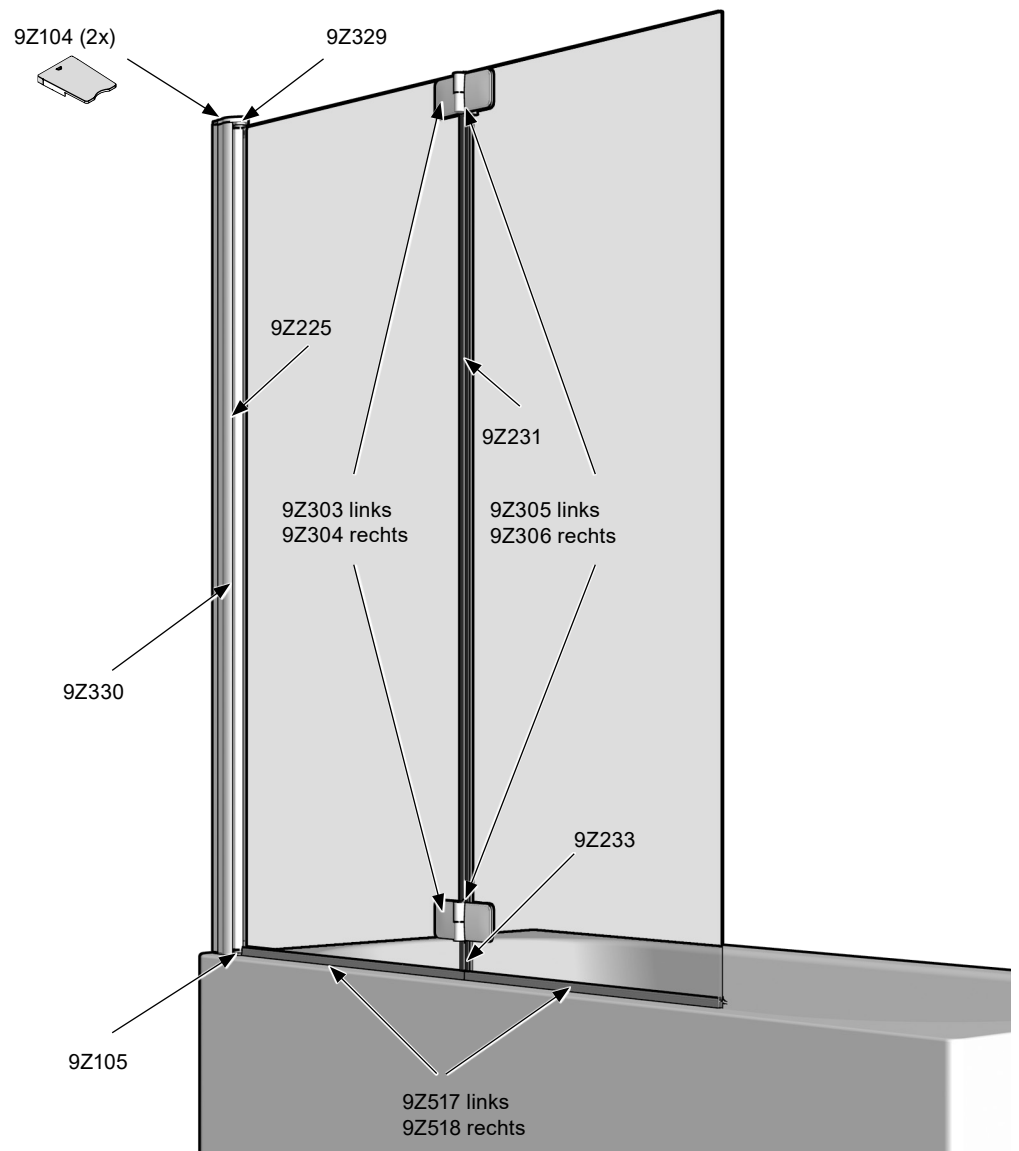

9Z231 / 9Z233

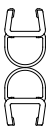

9Z225



9Z517 / 9Z518



Artweger GmbH. & Co. KG  
Sulzbacherstraße 60 | 4820 Bad Ischl | Austria  
Tel. +43 6132 205-0 | Fax +43 6132 205-5000  
info@artweger.at | www.artweger.at

Verkauf Deutschland  
Artweger GmbH. & Co. KG  
Postfach 1169 | 83402 Ainring | Deutschland  
Tel. 0800 1114442-0 | Fax 0800 1114442-41  
info@artweger.de | www.artweger.de

Verkauf Schweiz  
Artweger GmbH. & Co. KG  
Postfach 16 | CH-4202 Duggingen  
Tel. + 41 61 751 90 91  
info@artweger.com | www.artweger.com



Druck- und Satzfehler sowie technische Änderungen vorbehalten.  
Typographical errors and technical changes reserved.  
Sous réserve d'erreurs d'impression ou de syntaxe ainsi que de modifications techniques.  
Drukfouten, maatwijzingen en technische veranderingen voorbehouden.  
Ci riserviamo errori di stampa e variazioni tecniche.