

MONTAGEANLEITUNG  
**Fliesenträger / Paneele**

ASSEMBLY INSTRUCTIONS  
**Tile substrate / Panels**

NOTICE DE MONTAGE  
**Support de carrelage / Panneaux**

MONTAGEVOORSCHRIFT  
**Onderbouw voor betegeling / Panelen**

**DUF0..**  
**DUPO..**  
**DDFO..**

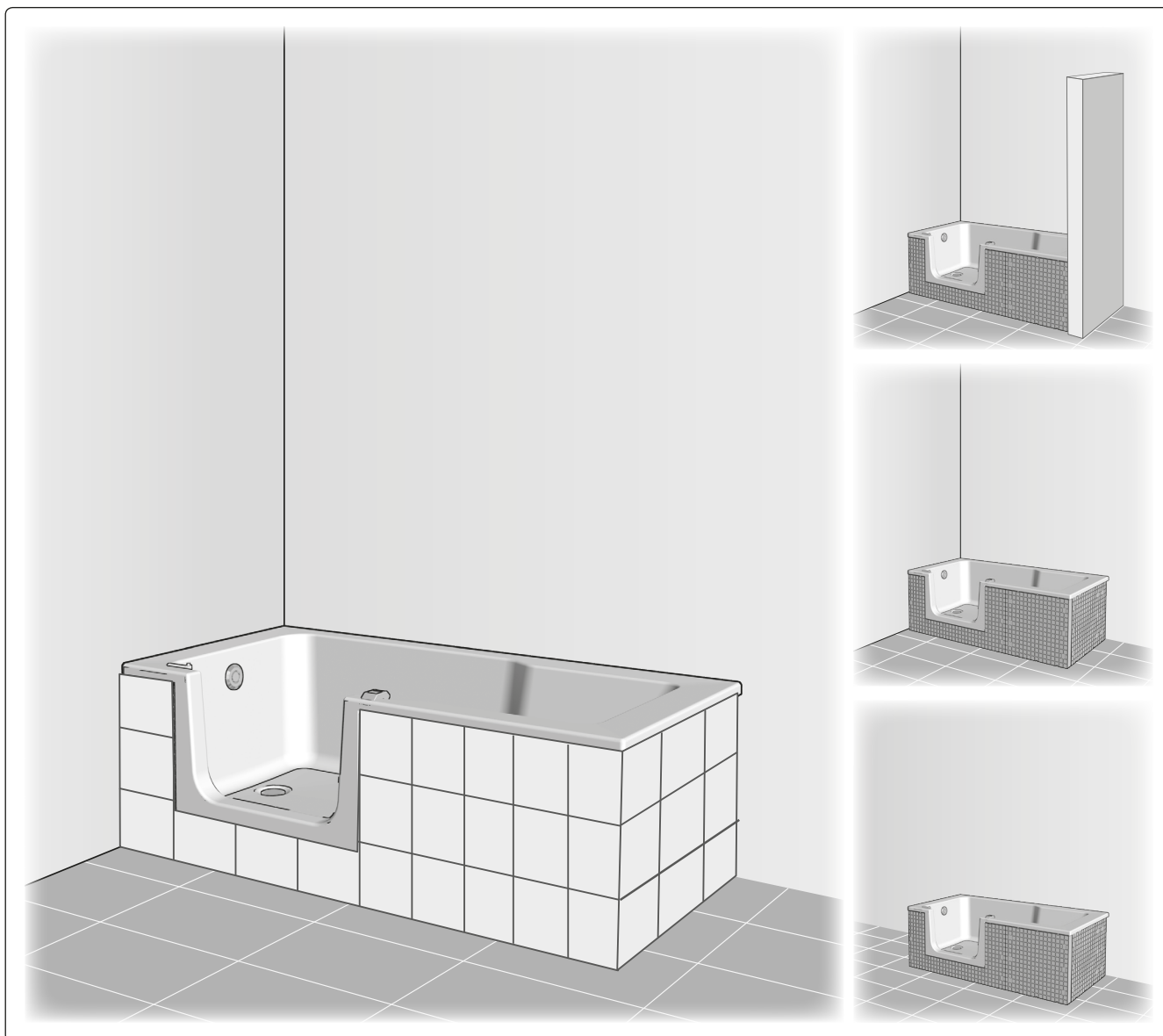

**Vor Gebrauch sorgfältig lesen!** Zum Nachschlagen und Aufbewahren dem Endkunden übergeben!

**Read carefully before use!** Hand over to the customer for looking up and storage!

**Avant emploi lire soigneusement!** Remettez le au client pour la recherche et le stockage!

**Voordien gebruik zorgvuldig lezend!** Overhandig de klant voor het kijken omhooggaand en opslag!

**DEUTSCH**  
Originalsprache

**ENGLISH**  
Translation

**FRANCAIS**  
Traduction

**NEDERLANDS**  
Vertaling

## INHALTSVERZEICHNIS

INHALTSVERZEICHNIS .....	2
SICHERHEITS-HINWEISE.....	4
BENÖTIGTES WERKZEUG .....	5
MONTAGESET .....	5
VARIANTE .....	6
MONTAGE .....	7
» Paneele .....	8
» Fliesen .....	8
» Abdichten mit Sanitärsilikon .....	15

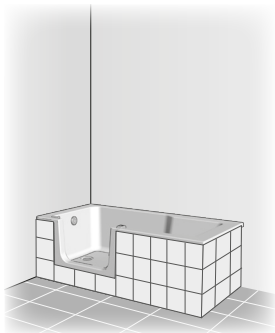

**Montageanleitung für Einbau LINKS -**  
bei Einbau RECHTS - spiegelgleicher Aufbau.

## OVERVIEW

OVERVIEW .....	2
SAFETY INSTRUCTIONS .....	4
NECESSARY TOOLS .....	5
ASSEMBLY KIT .....	5
VARIANTE .....	6
ASSEMBLY .....	7
» Panels .....	8
» Tiles .....	8
» Sealing with sanitary silicone.....	15

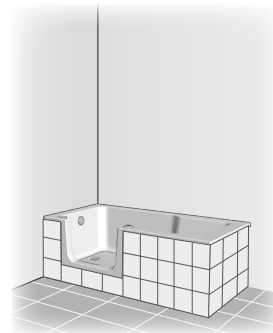

**Assembly instructions for installation**  
**LEFT -**  
for installation RIGHT - assemble in mirror image.

## VUE D'ENSEMBLE

VUE D'ENSEMBLE .....	3
INSTRUCTIONS SÉCURIT .....	4
OUTILLAGE NECESSAIRE .....	5
SET DE MONTAGE.....	5
VARIANTE .....	6
MONTAGE .....	7
» Panneaux .....	8
» Carrelage .....	8
» Etancher avec du silicone sanitaire .....	15

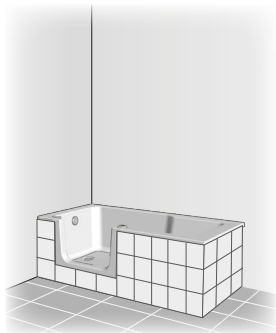

**C'est prévue pour une installation à  
GAUCHE –**

en cas d'une installation à DROITE -A inverser pour  
partie fixe en GAUCHE.

## OVERZICHT

OVERZICHT .....	3
VEILIGHEIDS VOORSCHRIFTEN .....	4
BENODIGD GEREEDSCHAP .....	5
MONTAGESET .....	5
VARIANTE .....	6
MONTAGE .....	7
» Panelen .....	8
» Tegels.....	8
» Afdichten met sanitair-siliconen.....	15

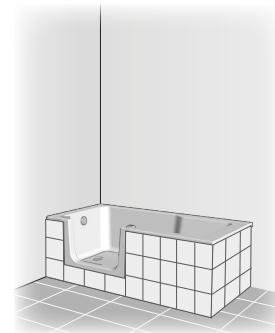

**Montagevoorschrift voor inbouw LINKS -**

bij inbouw RECHTS - montage in spiegelbeeld.

## DE Vor dem Einbau bitte unbedingt beachten!

- Produkt **vor dem Einbau**, auf Richtigkeit, Beschädigungen und das Zubehör auf Vollständigkeit **überprüfen**.
- **Bei sichtbarem Schaden Produkt keinesfalls einbauen!**
- **Beachten Sie beim Hantieren das teilweise hohe Gewicht und/oder die großen Abmessungen von Einzelteilen.**
- **Beachten Sie beim Bohren der Löcher, dass Sie keine Leitungen (Elektro, Gas, Wasser) beschädigen.**



Unsere Haftung beschränkt sich alleine auf unsere Produkte und kann daher nicht auf den Ein- und Ausbau ausgedehnt werden. Die Kosten für einen nachträglichen Aus- und Einbau eines Produkts und die damit verursachten Schäden sind **kein** Bestandteil der Garantie.

## EN Please note carefully before installing

- Before installing, check for correctness and damage and the accessories for completeness.
- **Do not under any circumstances install product with visible damage!**
- **Take the great weight and/or the large dimensions into consideration when handling individual parts!**
- **When drilling holes do not damage hidden pipes and wiring.**

Our liability is limited to our products alone and therefore cannot be extended to installation and dismantling. Costs for subsequent dismantling and installation of a product and damage caused thereby are not part of the guarantee.

## FR A respecter impérativement avant le Montage

- Avant le montage de vérifier qu'il s'agit du bon modèle, qu'elle n'est pas endommagée et que les accessoires sont complets.
- **En cas de dommages visibles, ne pas monter le produit!**
- **Lors de la manutention, merci de prêter attention au poids parfois très élevé et/ou aux dimensions de certaines pièces!**
- **Faites attention en perçant les trous de ne pas endommager les tuyauteries (cables électriques, canalisations de gaz, d'eau, etc).**

Notre responsabilité se limite à nos produits et ne peut être étendue sur l'installation et le démontage. Les coûts générés lors d'un démontage après installation et d'une ré-installation d'un produit et les dommages qui en résultent ne pourront être pris en charge par la garantie.

## NL Voor inbouw beslist in acht nemen!



- Bad voor het inbouwen op juistheid, beschadigingen en toebehoren op volledigheid controleren.
- **Bij zichtbare beschadiging product in geen geval inbouwen!**
- **Let u bij het gebruik om het gedeeltelijk grote gewicht en/of de grote afmetingen van enkele onderdelen!**
- **bij het boren van gaten er op letten, dat U geen leidingen (elektro, gas of water) beschadigt!**

Wanneer het bad betegeld wordt, beslist de inbouwmaten van de badkuip en van de doucheafscheiding in acht nemen. Onze aansprakelijkheid is beperkt tot onze producten en kan daarom niet op de in- en uitbouw uitgebreid worden. De kosten voor een latere uit- en inbouw van een product en de daaruit voortvloeiende schade zijn geen onderdeel van de garantie.

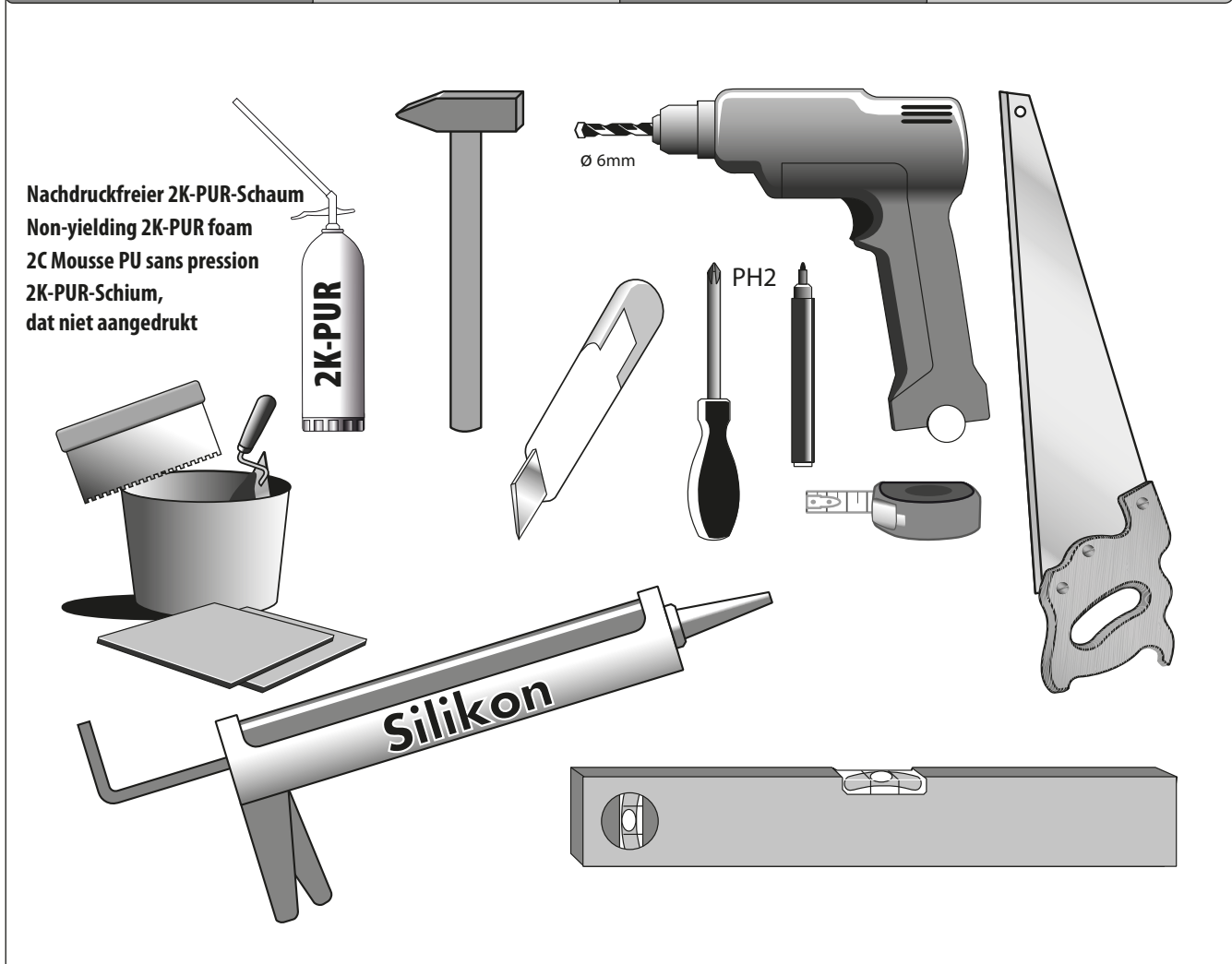
BENÖTIGTES WERKZEUG	NECESSARY TOOLS	OUTILLAGE NECESSAIRE	BENODIGD GEREEDSCHAP
---------------------	-----------------	----------------------	----------------------

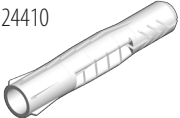
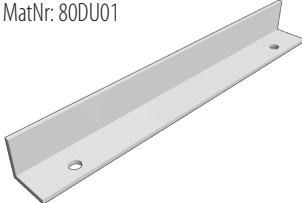
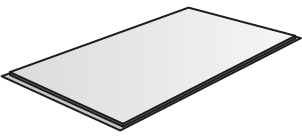
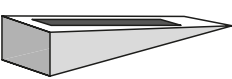

MONTAGESET	ASSEMBLY KIT	SET DE MONTAGE	MONTAGESET
------------	--------------	----------------	------------

<p><b>2x</b> 4,2X25mm MatNr: 24193</p> 	<p><b>2x</b>-4,3-A2 MatNr: 2461</p> 	<p><b>2x</b> Ø 6mm MatNr: 24410</p> 	<p><b>1x</b> MatNr: 80DU01</p> 
<p><b>10x</b> MatNr: 18401</p> 	<p><b>4x</b> MatNr: 706536</p> 		

VARIANTE

VARIANTE

VARIANTE

VARIANTE

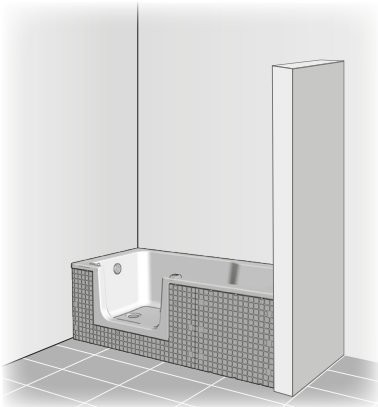

1.

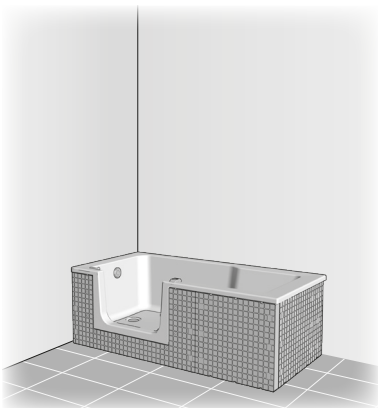
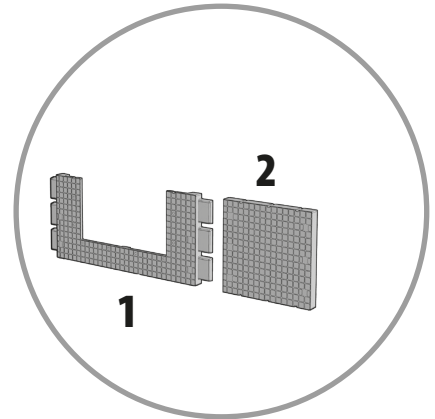
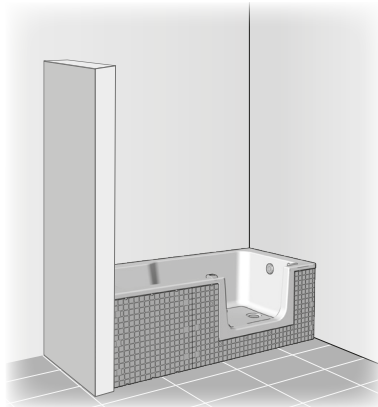

2.

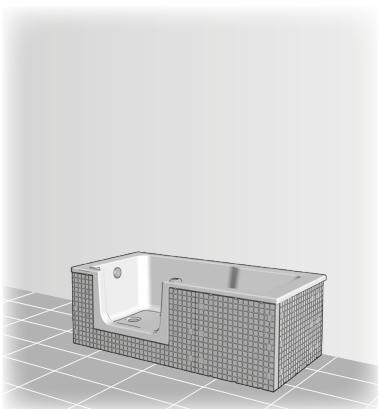
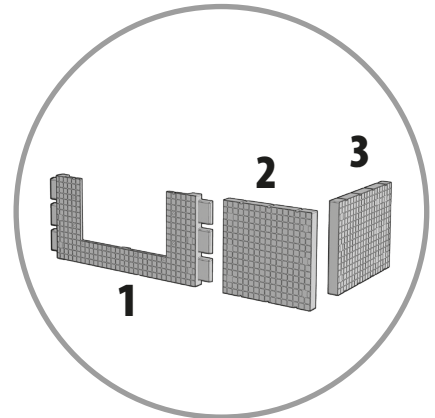
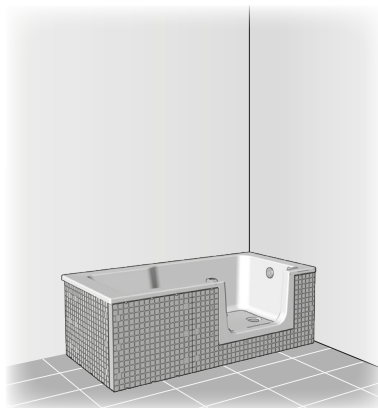

3.

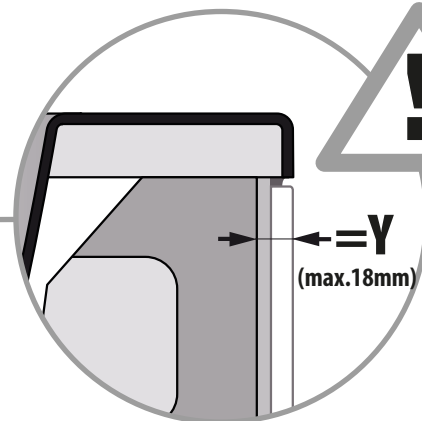
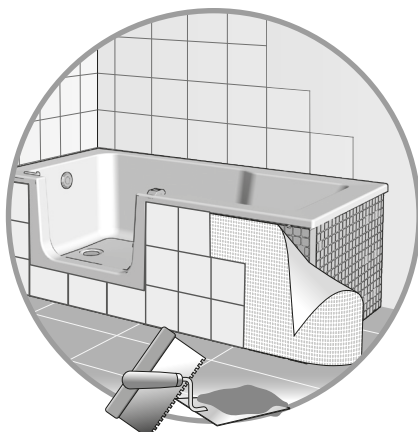
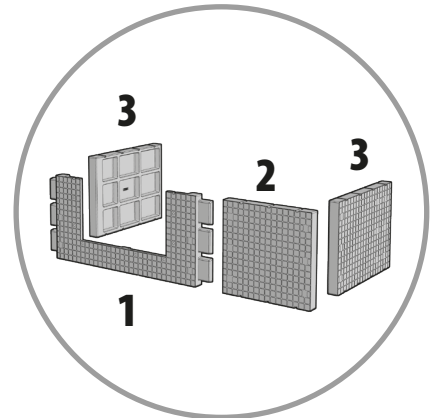
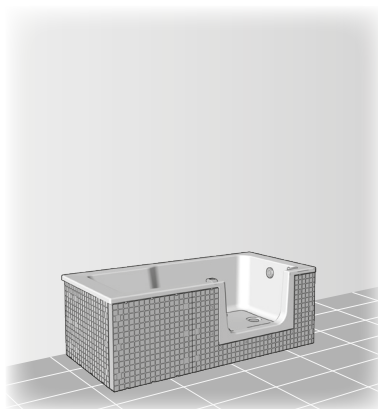

1

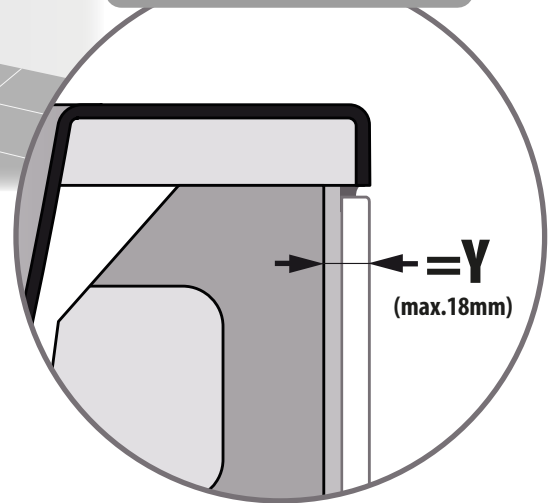
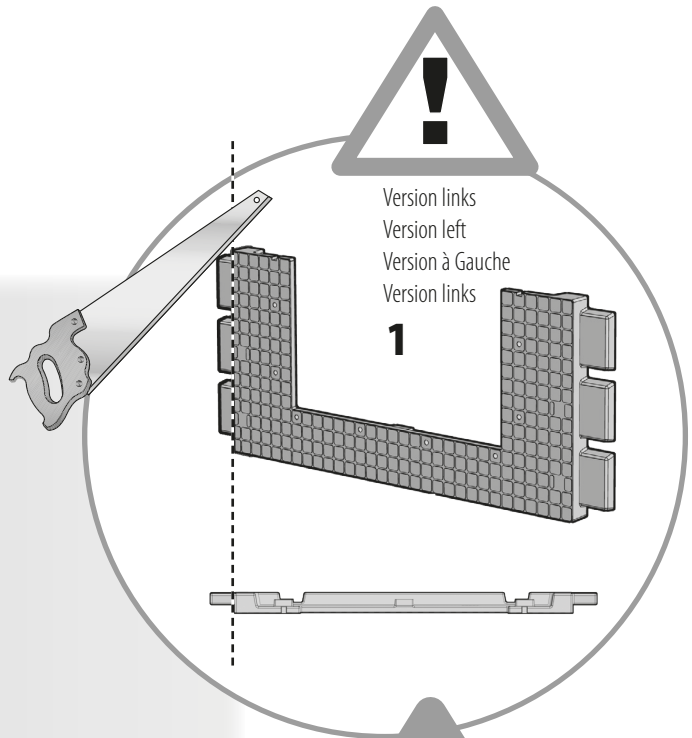

2

**VARIANTE A**  
Paneele, Panels, Panneaux, Panelen

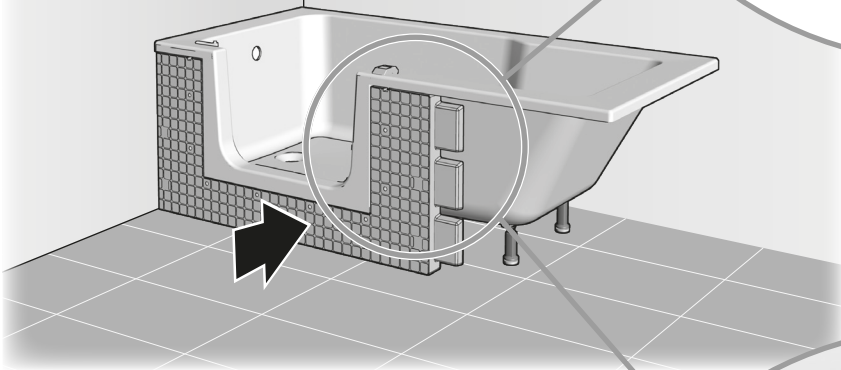
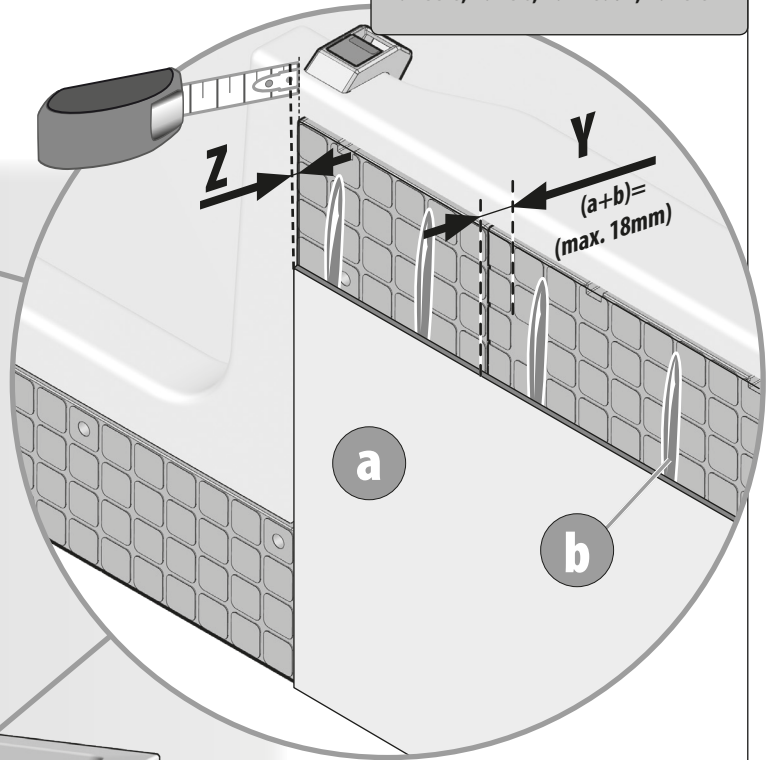
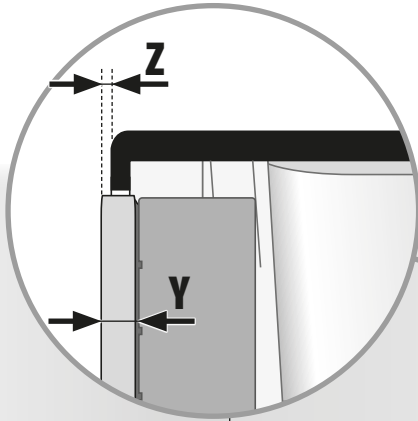

**VARIANTE B**  
Fliesen, Tiles, Carrelage, Tegels

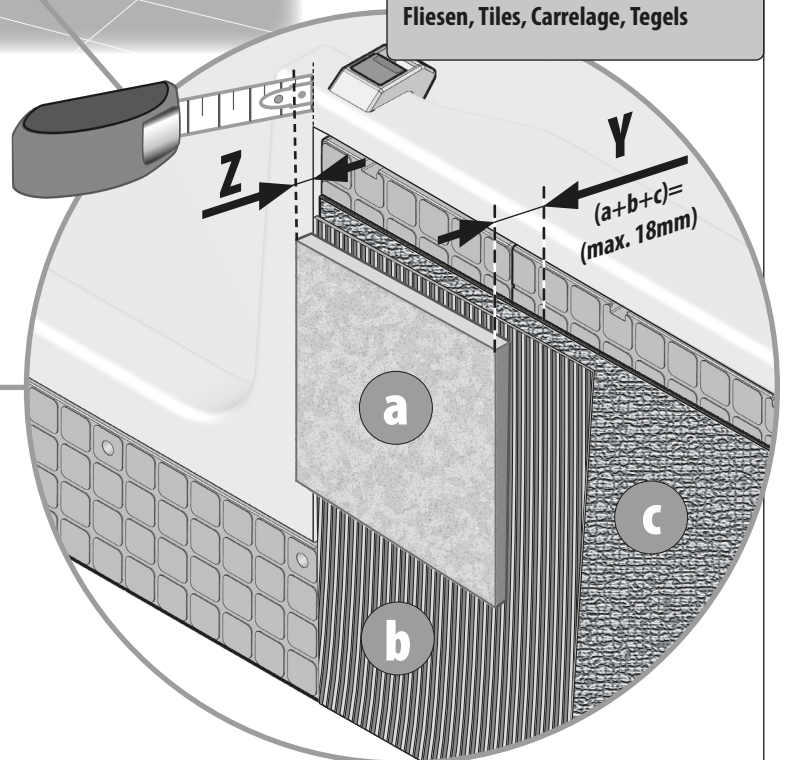
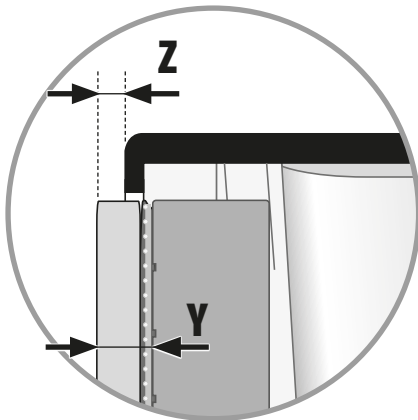



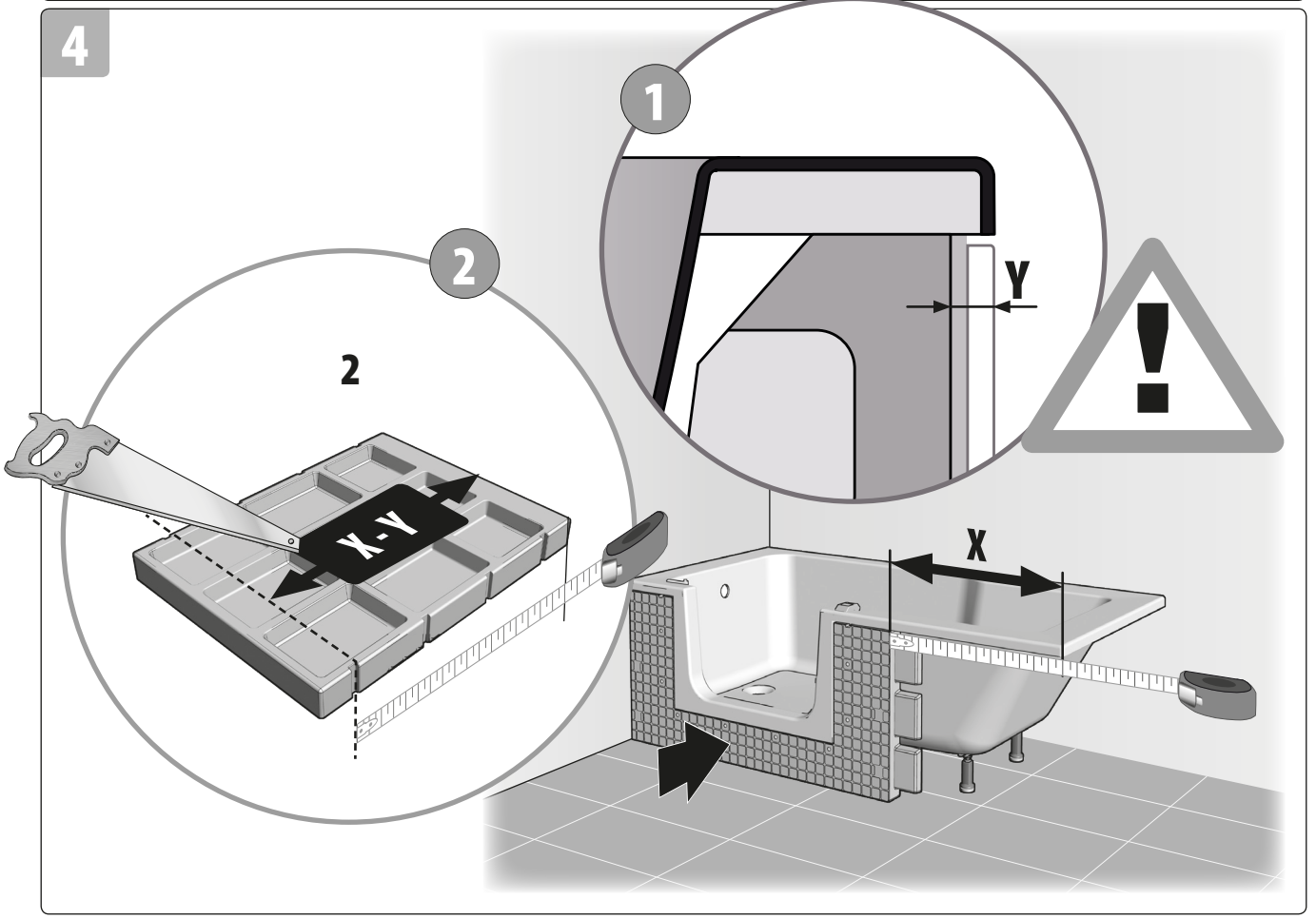
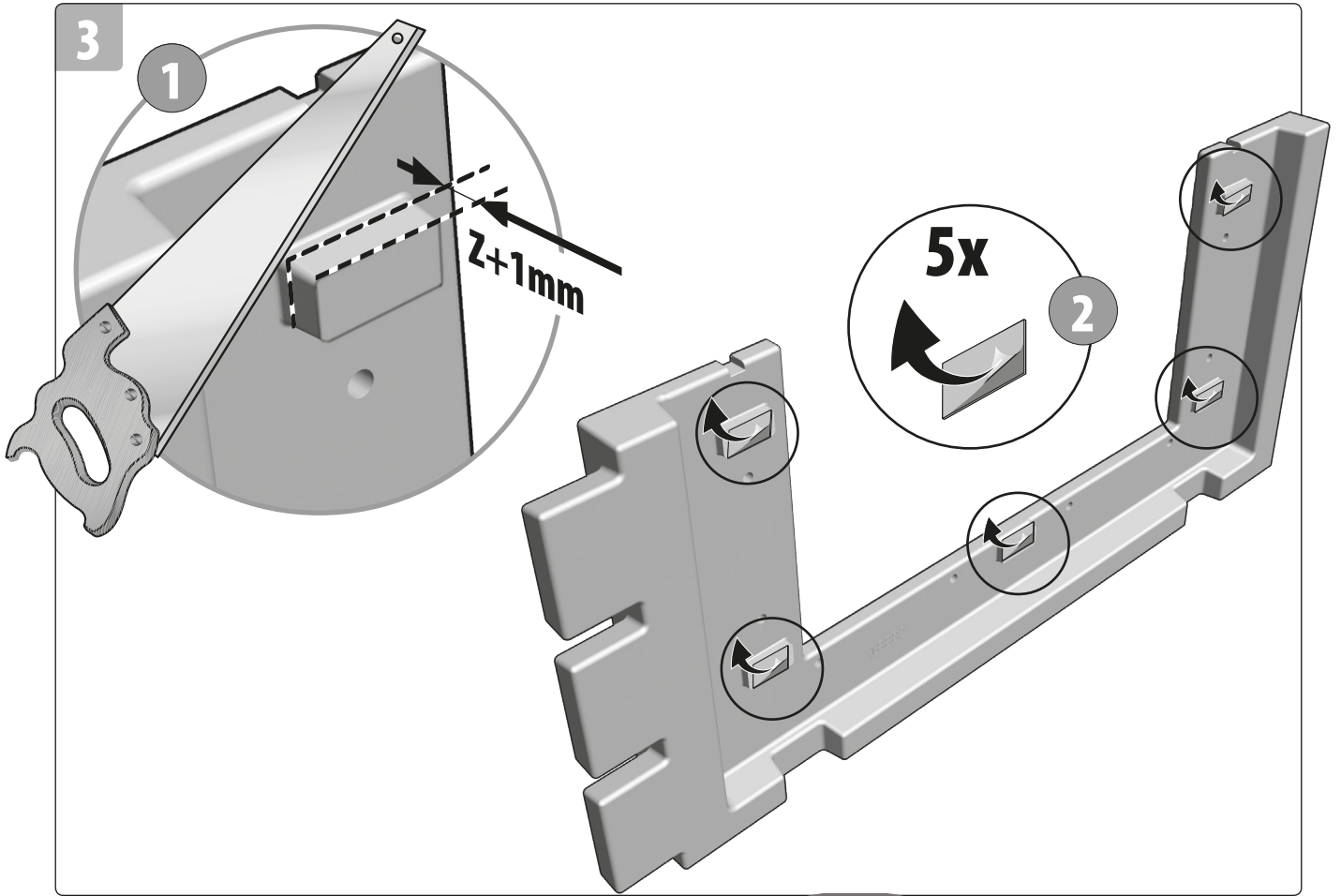

5

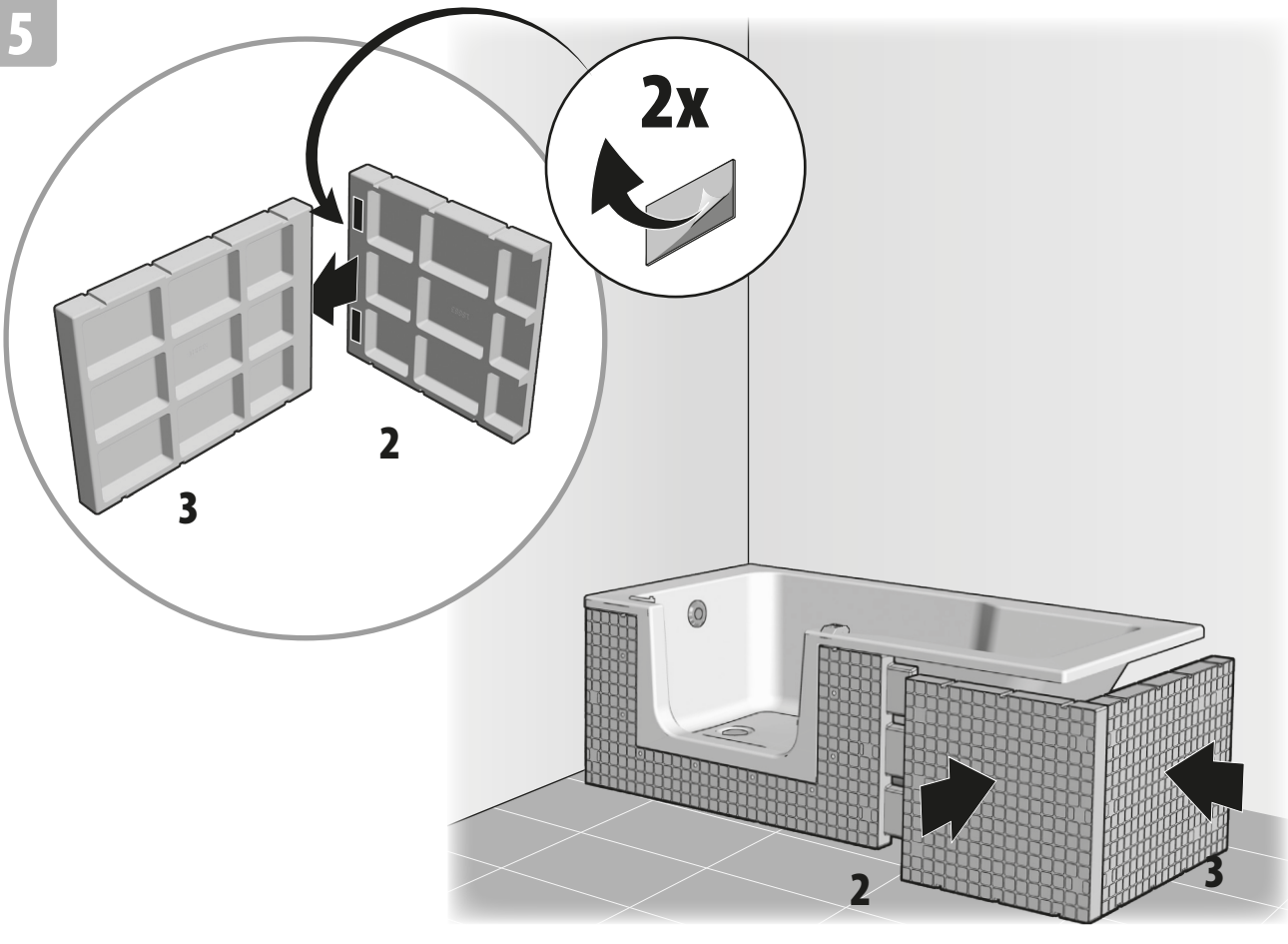

6

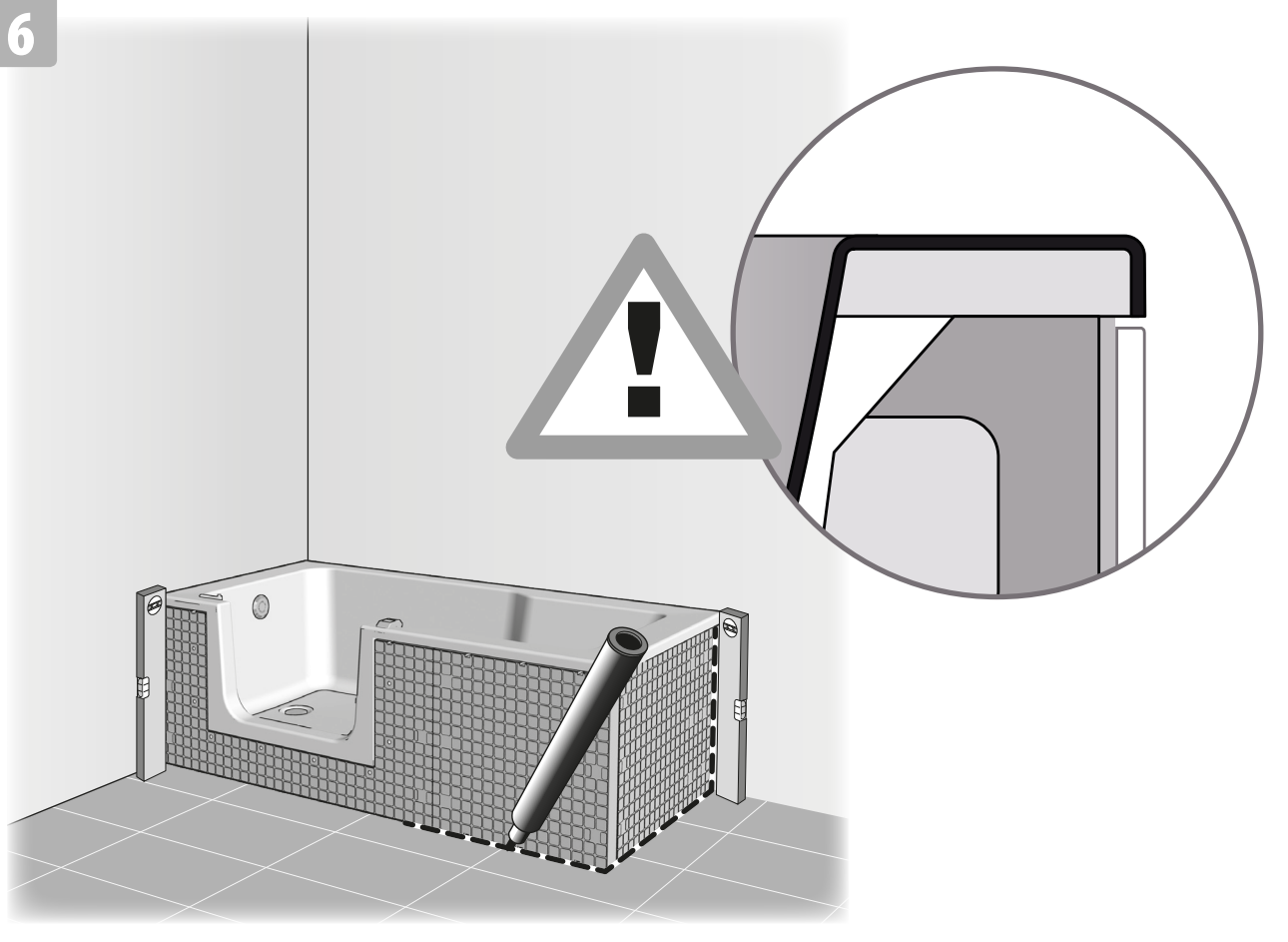

7

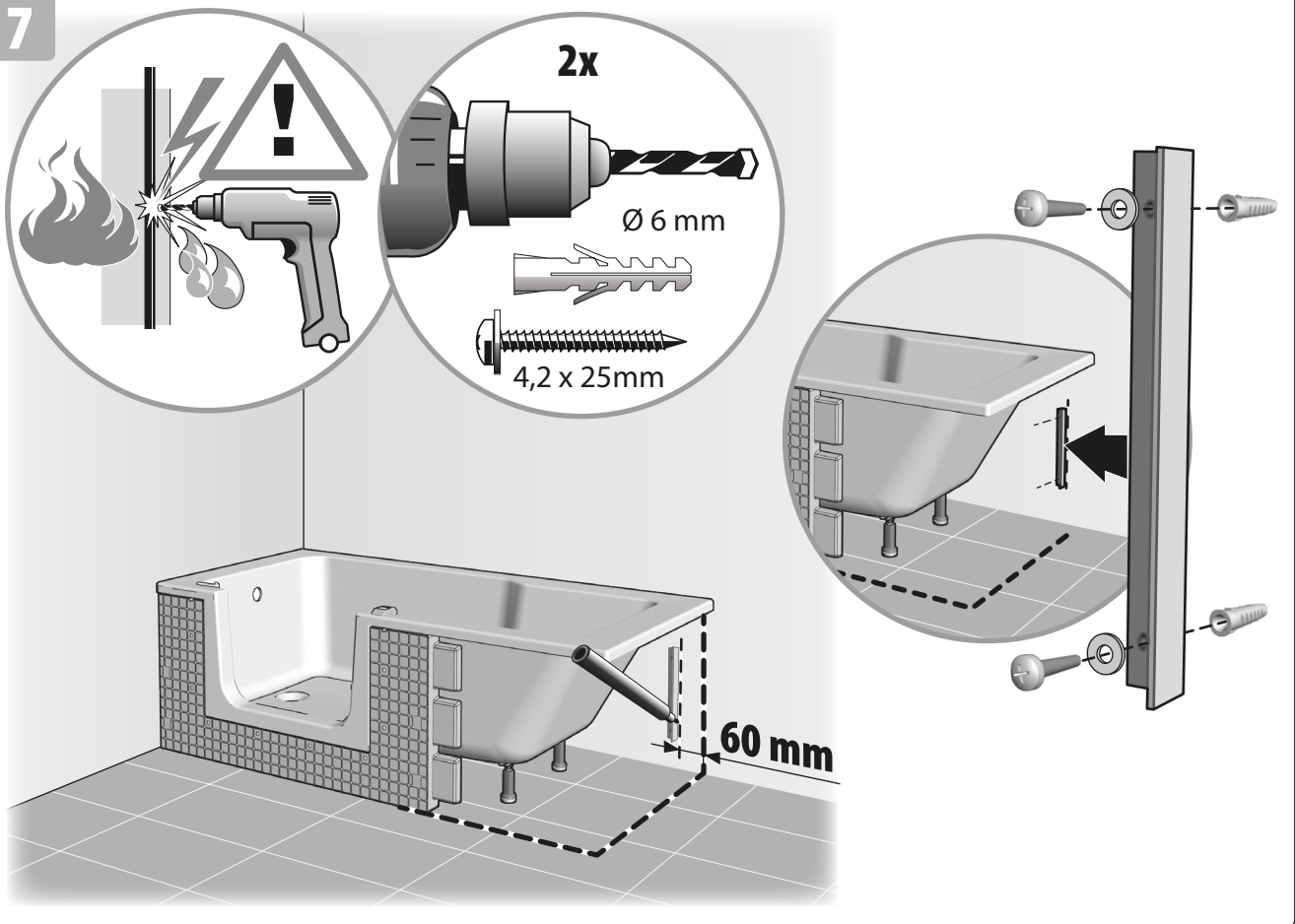

8

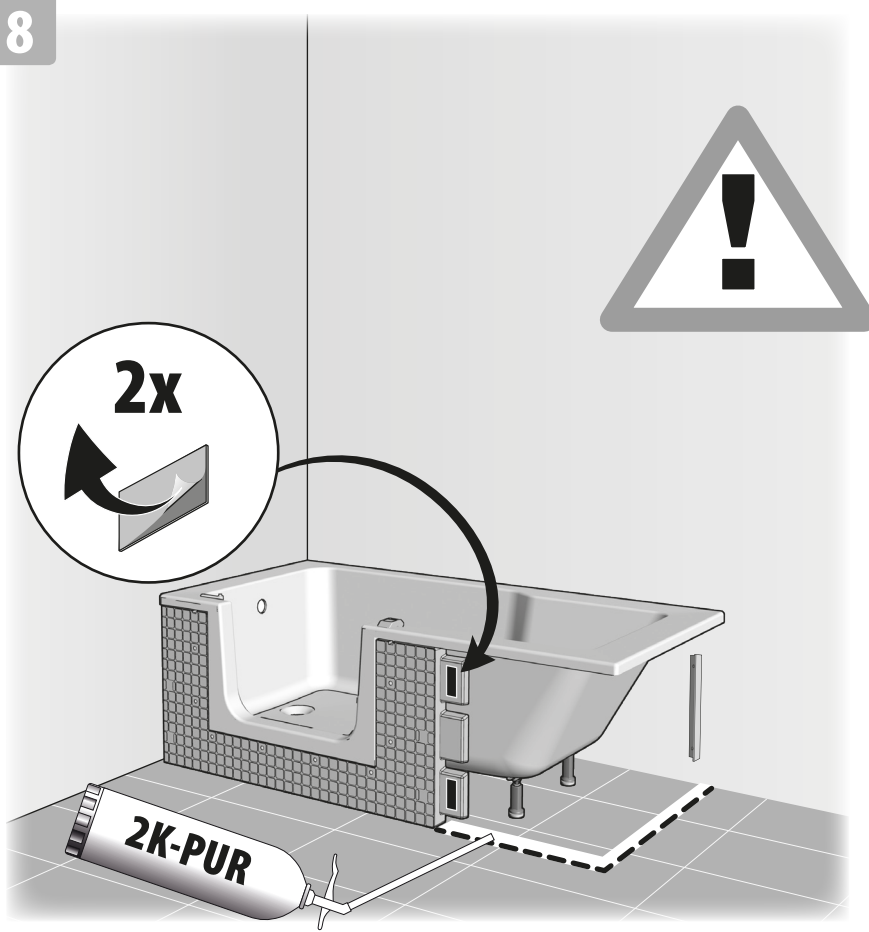

**DE** Wichtig! Verwenden Sie **ausschließlich nachdruckfreien 2K-PUR-Schaum!**

**EN** IMPORTANT! Use only **non-yielding 2K-PUR foam!**

**FR** IMPORTANT! Utilisez **exclusivement la mousse K-PUR qui ne déforma pas sous la pression après séchage!**

**NL** BELANGRIJK! Gebruik uitsluitend **2K-PUR-schuim, Dat niet aangedrukt hoeft te worden!**

9

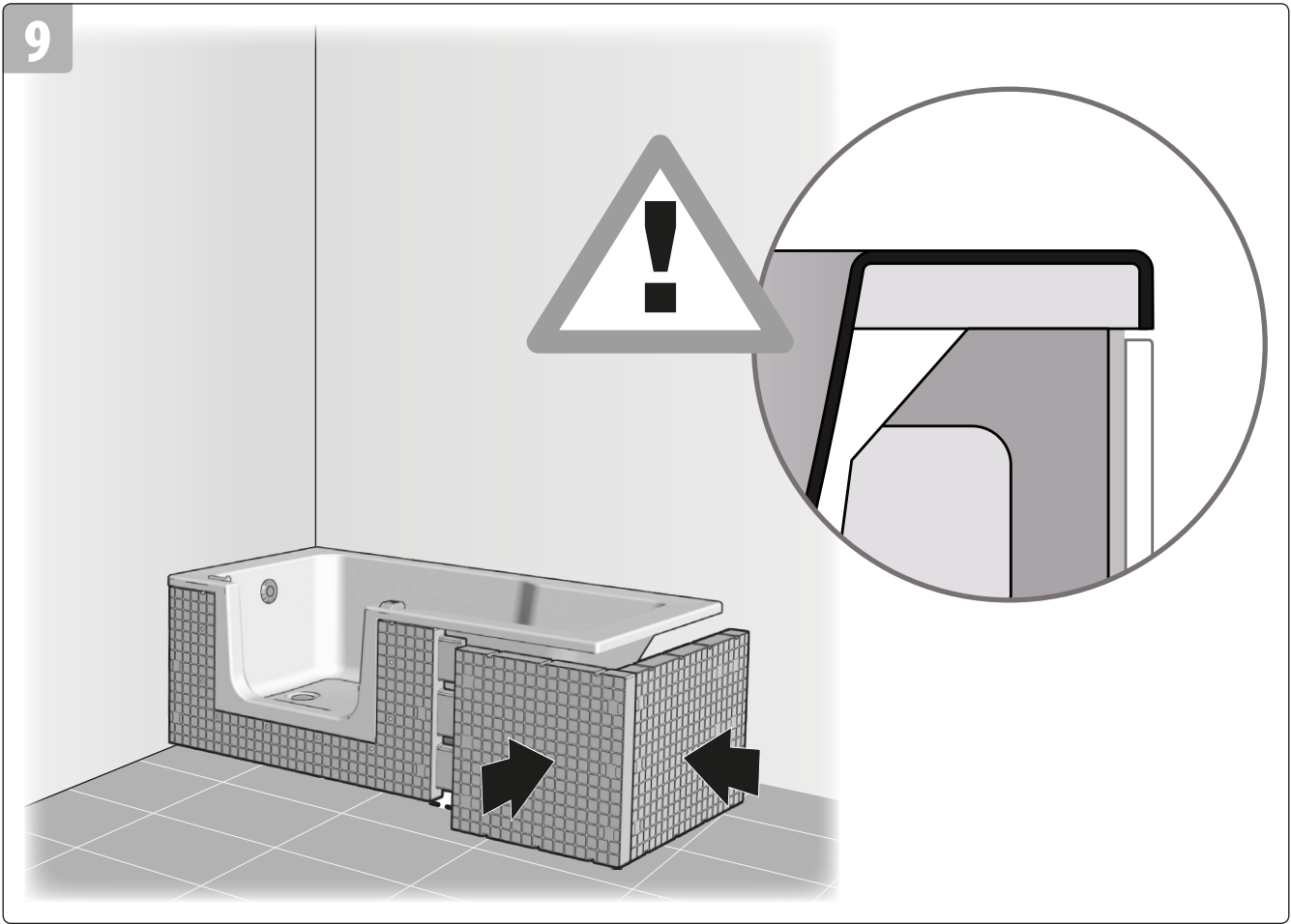

10

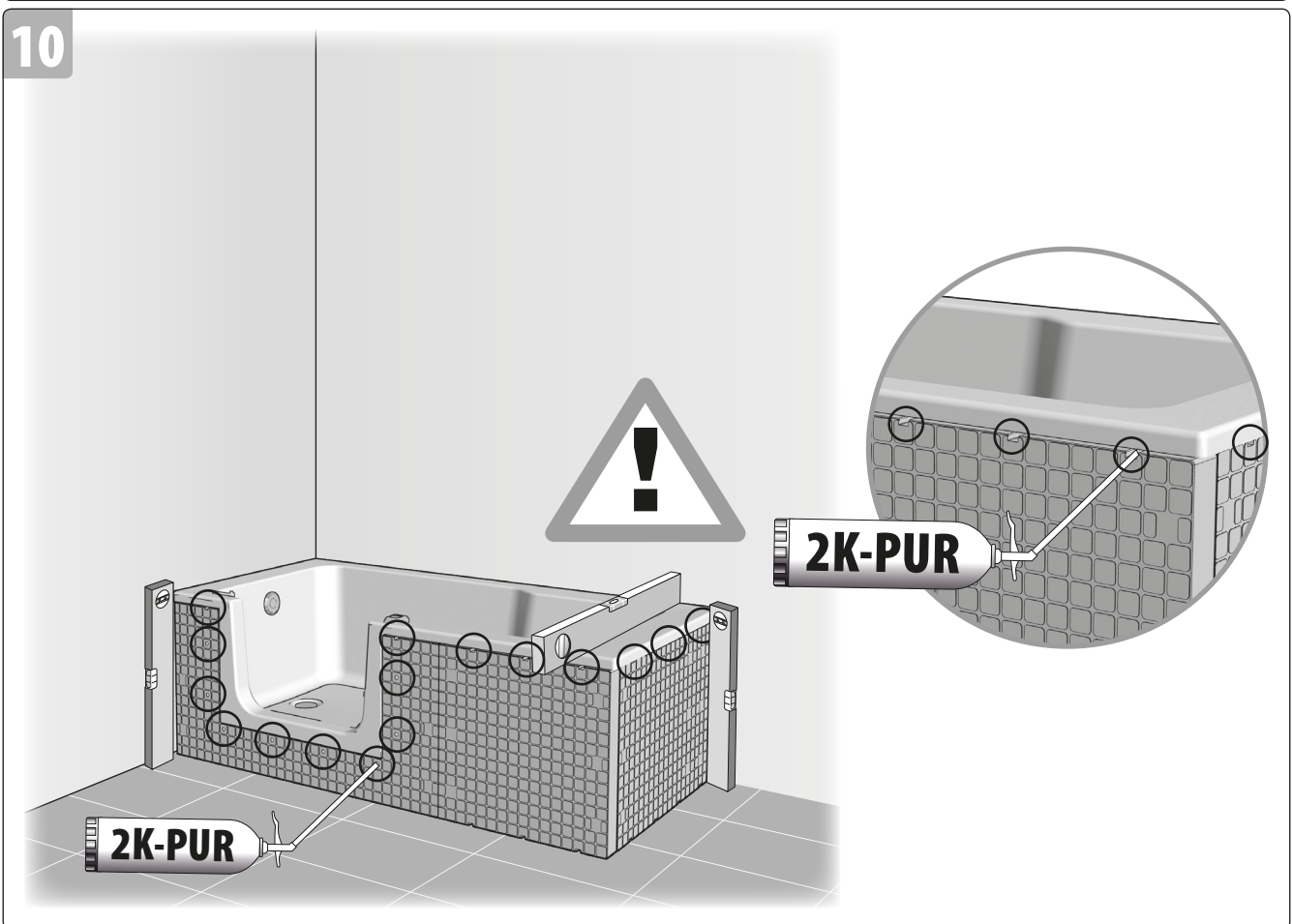

11

VARIANTE A

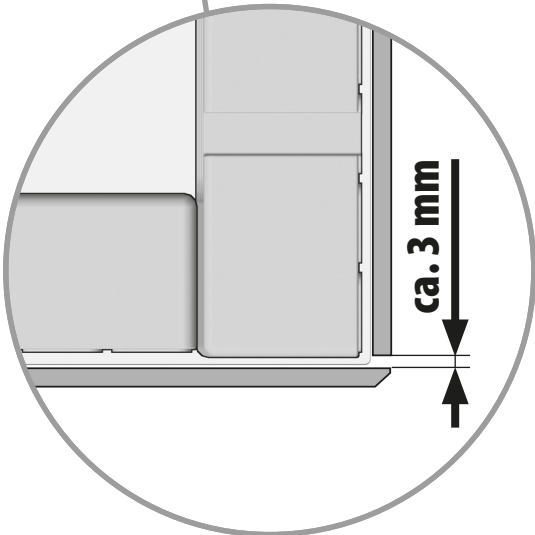
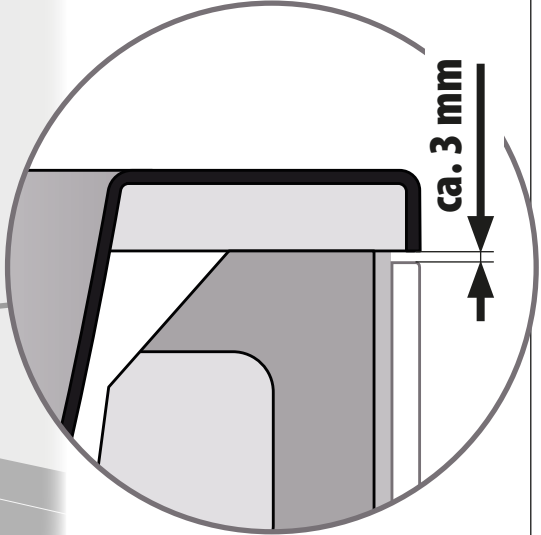
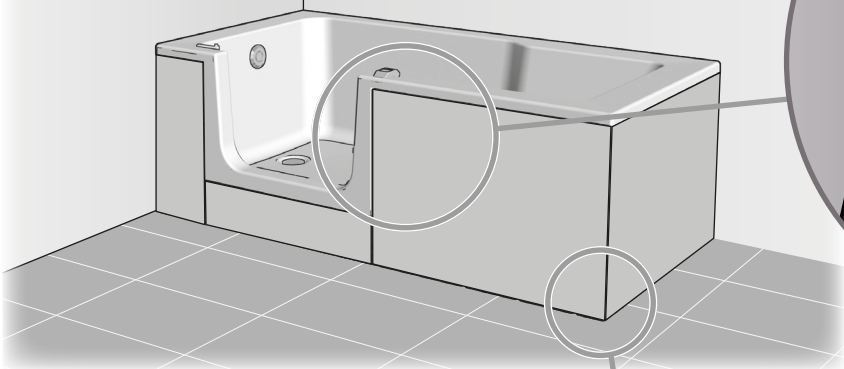
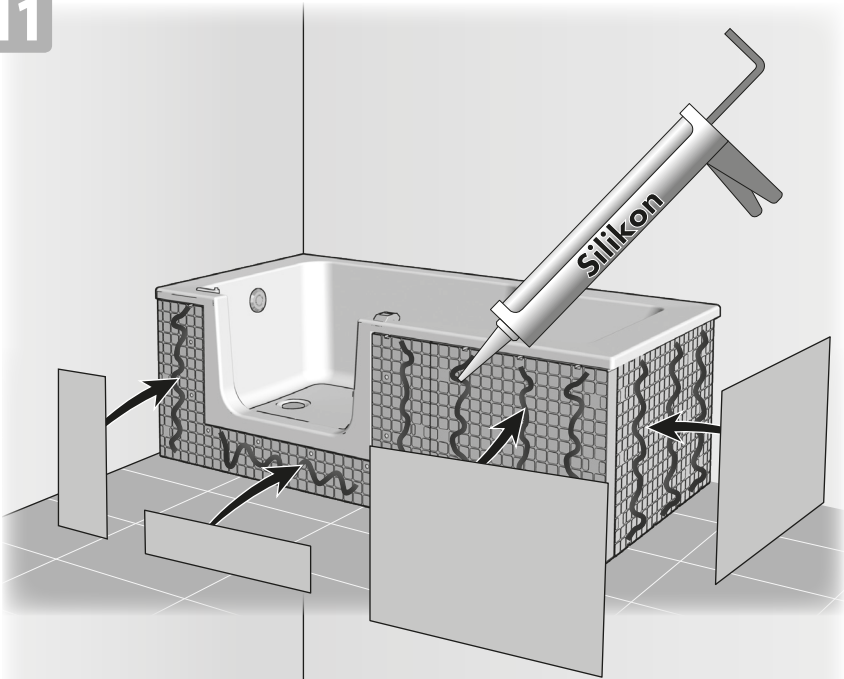

12

VARIANTE B

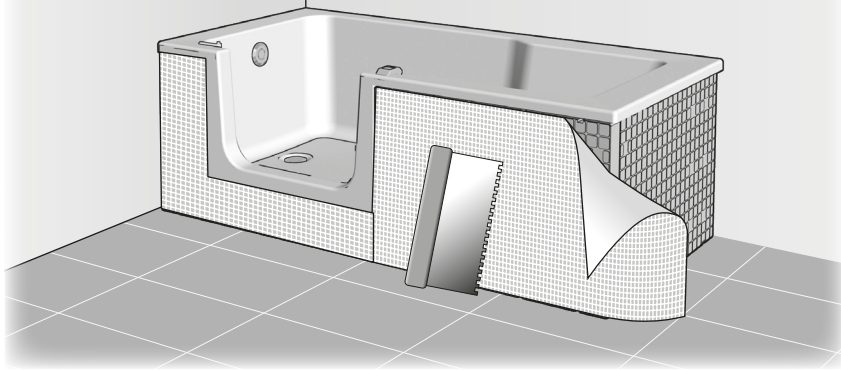

**DE** Armierungsgewebe mittels **Dispersionskleber** aufbringen.

**EN** Apply front lattice by means of **dispersion adhesive**.

**FR** Appliquer la grille de facade à l' aide d' une **colle à dispersion**.

**NL** Voorkantraster met **dispersielijm** aanbrengen.

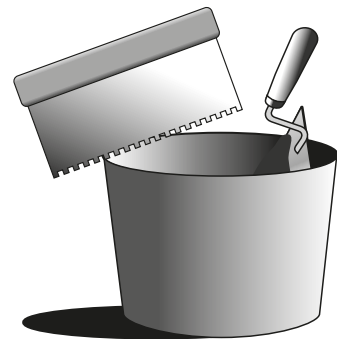

13

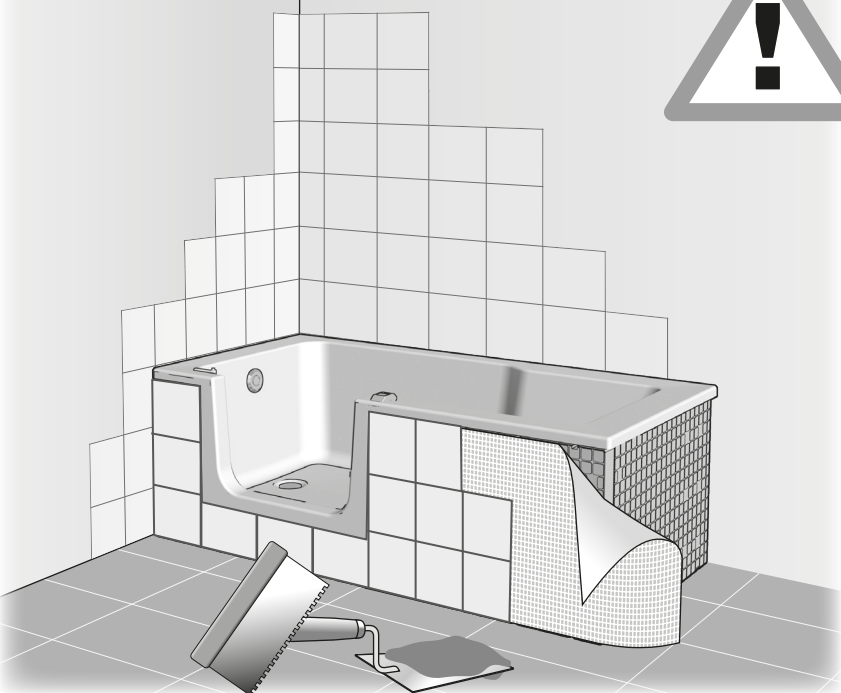
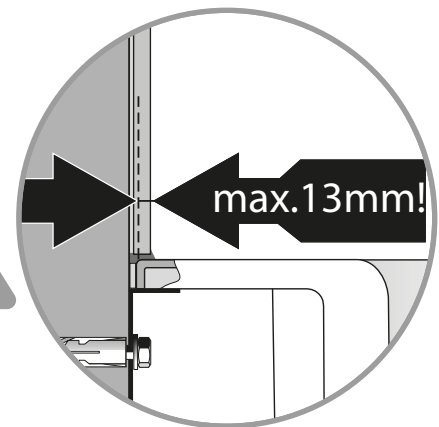



14

VARIANTE B

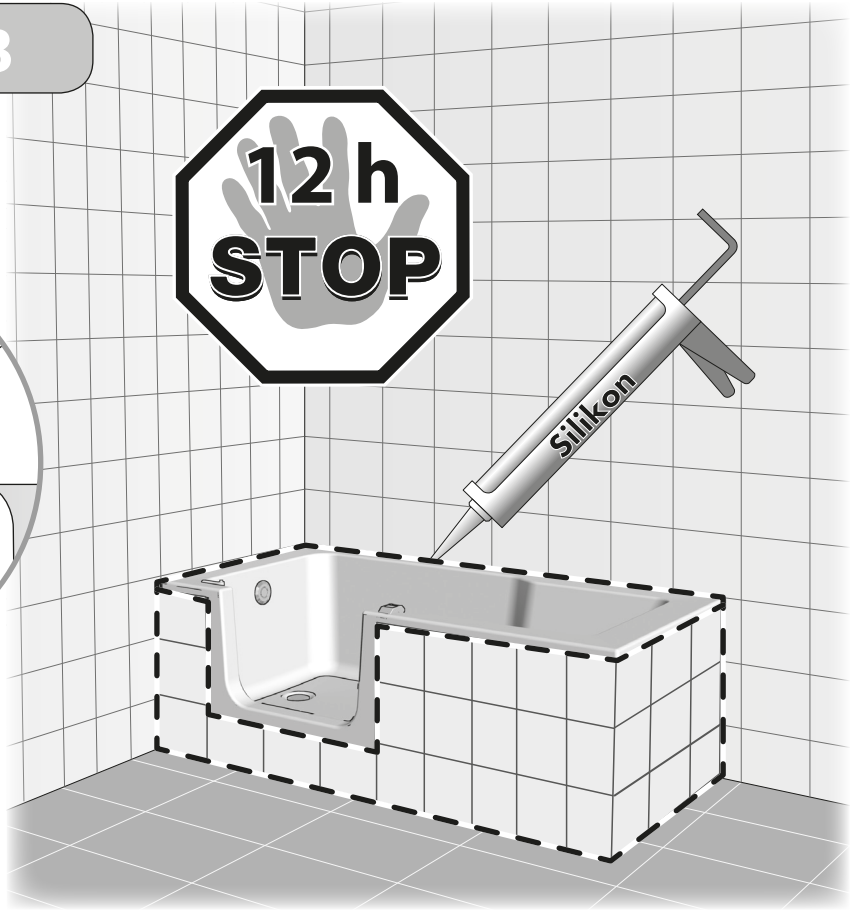

15

VARIANTE A

