

Artweger®
TWINLINE

The one-two punch
for your bathroom



„I like showers!“

„I prefer baths!“

PRE-INSTALLATION-DOCUMENTS

TWINLINE

CONTENTS

CONTENTS	2
» PRE-INSTALLATION - NOTES	3
» PROTECTED AREAS.....	3
ARTWEGER TWINLINE 1.....	4
» INSTALLATION - on completed floor	5
» INSTALLATION ON STRAIGHT WALL - on completed floor.....	5
» INSTALLATION - on raw concrete (casing dimensions)	6
» ODOUR-TRAP installation area	7
ARTWEGER TWINLINE 1 AIR / Coloured light.....	8
» INSTALLATION - on completed floor	9
» INSTALLATION ON STRAIGHT WALL - on completed floor.....	9
» NOTES.....	10
» WIRING diagram.....	11
ARTWEGER TWINLINE 2.....	12
» INSTALLATION - on completed floor	13
» INSTALLATION ON STRAIGHT WALL - on completed floor.....	13
» INSTALLATION - on raw concrete (casing dimensions)	14
» ODOUR-TRAP installation area	14
» For installation on tiled walls	15
ARTWEGER TWINLINE 2 AIR / Coloured light.....	16
» INSTALLATION - on completed floor	17
» INSTALLATION ON STRAIGHT WALL - on completed floor.....	17
» ODOUR-TRAP installation area	18
» WIRING diagram.....	19

*All the pictures refer to installing TWINLINE models with entry on the left.
For models with entry on the right, install symmetrically to the pictures.*

PRE-INSTALLATION - NOTES

Water inlet and outlet according to DIN 1986 and DIN 1988 as with a normal bathtub.
In case of the integrated tub inlet (optional equipment) a pipe interrupter (type A2) according to EN 1717 is to be installed.

A pipe interrupter must be installed in accordance with the valid local standards and regulations! Ensure that on-site preparations adhere to country-specific standards, e.g. ÖNORM B 2207 or DIN 18515-1 (standards for tiling/sealing against dampness). (Seal the splash area and the entire floor area with liquid sealing foil!)

The two walls that the TWINLINE tub is mounted on must be at an exact 90-degree angle to one another.



Electrical installation may only be carried out by a qualified, registered company in compliance with legislation guidelines as well as the currently valid edition of national installation regulations (e.g.; Austria OVE-E-8101; Germany DIN VDE 0100-701). Cable duct from above or below (min. 20 mm Ø, min. installation depth 5 cm). Separate mains supply line H05-VV-F (flexible line) over a RCD $\Delta I_N \leq 30$ mA. For connection a cable of approx. 3 m should be provided. Take care to comply with current regulations about potential equalization! Potential equalization line, 4 mm² (Cu) for connection to the standard ground terminal.

The line has to have a double-pole cut-off, with a min. 3 mm contact opening (outside of protected zone 2, e.g. protection switched over light switch with control indicator) in accordance with VDE 0100-701 respectively OVE-E-8101.

PROTECTED AREAS

For your personal safety, the protected areas must be adhered to exactly.

 = Protected area 2:
(Height 225 cm) No switches or power outlets allowed!

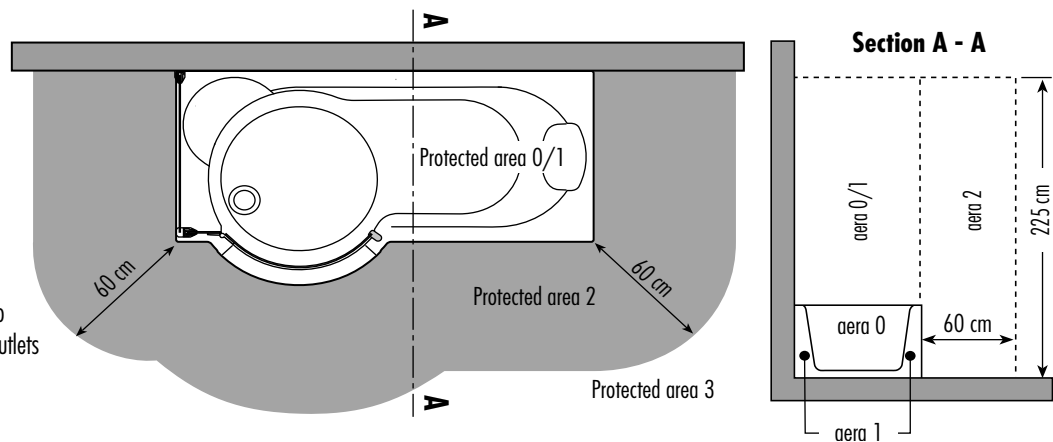

ARTWEGER TWINLINE 1



INSTALLATION - on completed floor

k	160	170	180	180 rounded
	50	50	55	55

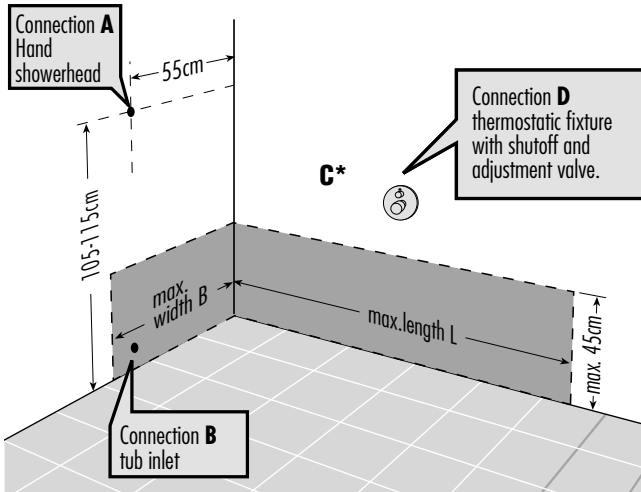

When installing the shower door on the already tiled wall a 0.8 cm compound bracket is required. Do not tile tub **before installation!**

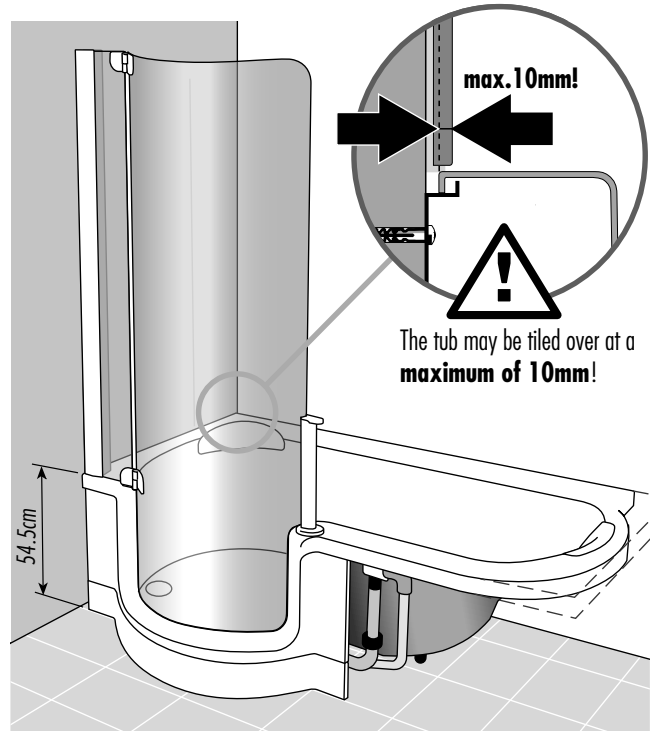

The area **under the tub** must also be **completely tiled!** However, the walls must **not be tiled.**

INSTALLATION ON STRAIGHT WALL - on completed floor

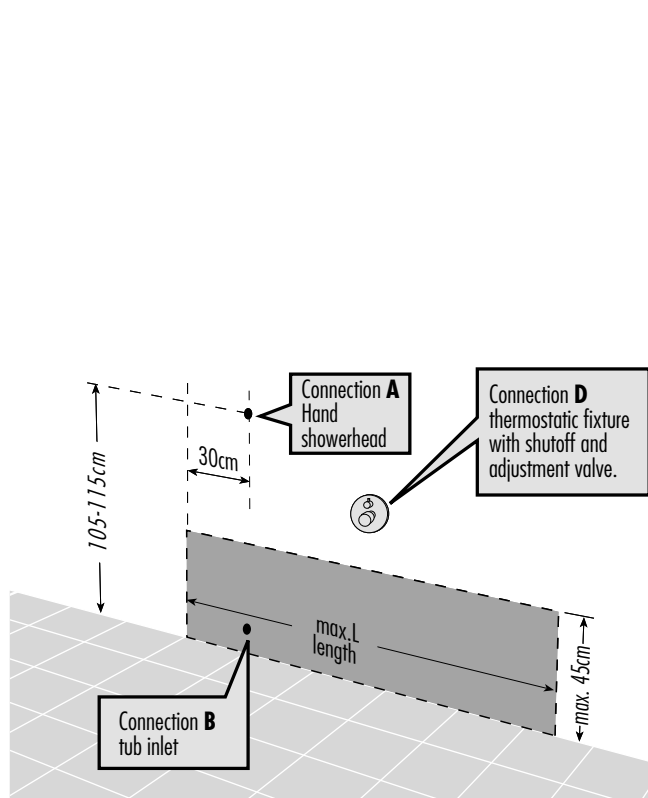

When installing the shower door on the already tiled wall a 0.8 cm compound bracket is required. Do not tile tub **before installation!**

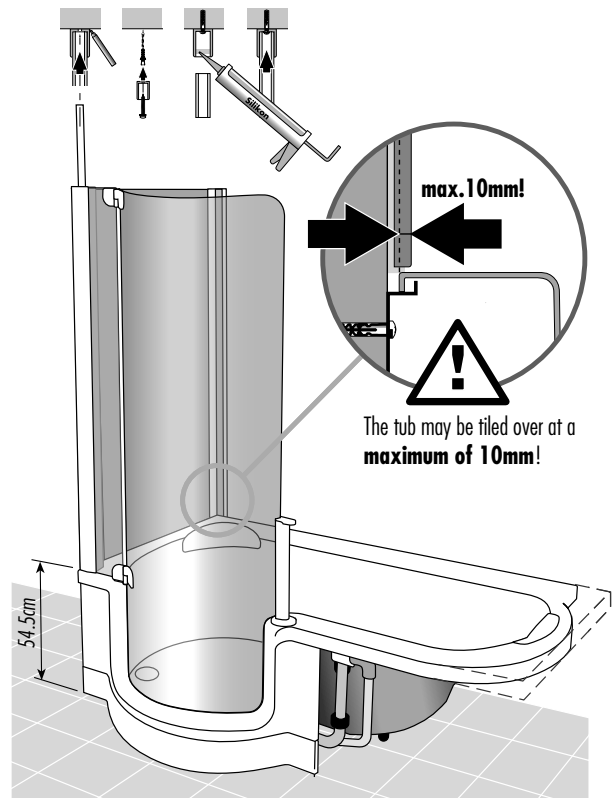

The area **under the tub** must also be **completely tiled!** However, the walls must **not be tiled.**

INSTALLATION - on raw concrete (casing dimensions)

Water (B) connections possible only within designated areas!

IMPORTANT!The dimensions of the casing must be **observed exactly!**

The tub can be set **exactly 11cm lower!**

The skirting (glass/Artwall) has to be ordered as a custom-made article!

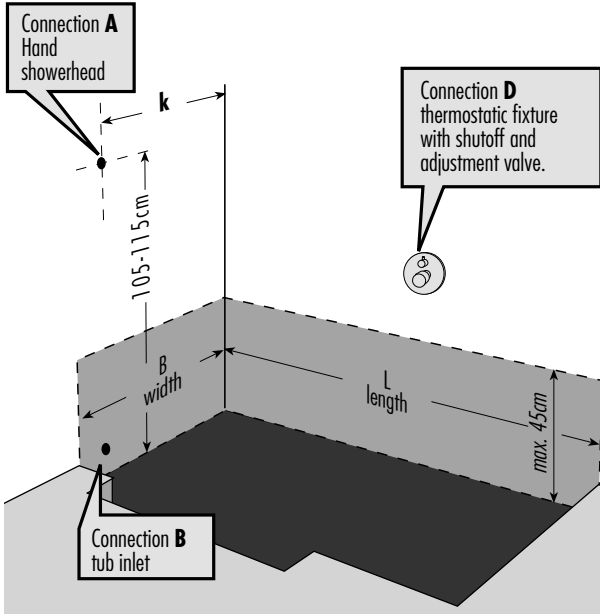

Connection D
thermostatic fixture
with shutoff and
adjustment valve.

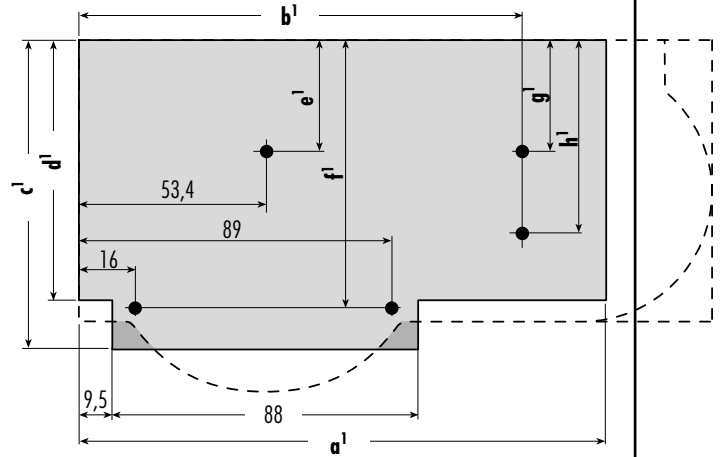

Twinline Badewanne	a ¹	b ¹	c ¹	d ¹	e ¹	f ¹	g ¹	h ¹
160	140	119	83	69	26,7	71,2	26,7	50
170	150	132	83	69	26,7	71,2	26,7	50
180	150	132	88	74	27,7	76,2	28,6	52
180 rond	150	132	88	74	31,7	76,2	31,7	55

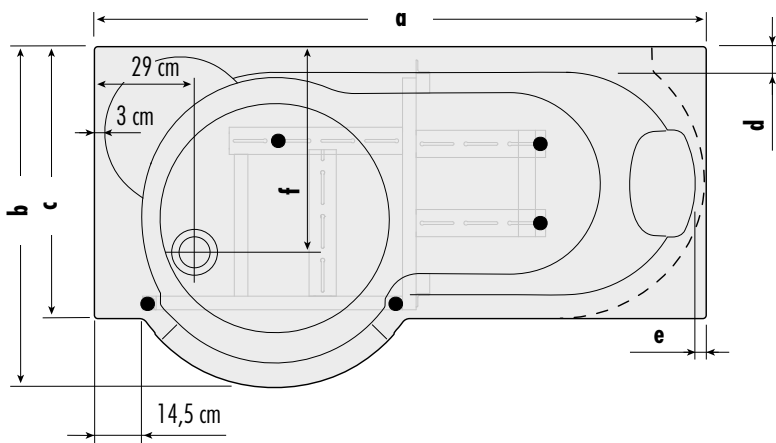

Total shower height	190/204,5
Room height required	+4,0
Entry height	17,5(11)
drain	50mm diam.

a	b	c	d	e	f	max.B	max.L
160	95	75	8,8	4	58	max.65	max.140
170	95	75	8,5	4	58	max.65	max.150
180	100	80	8	4	60,5	mac.70	max.160
180 gerundet	100	80	13,5	4	63	max.70	max.160

**All dimensions
in cm!**

ODOUR-TRAP installation area

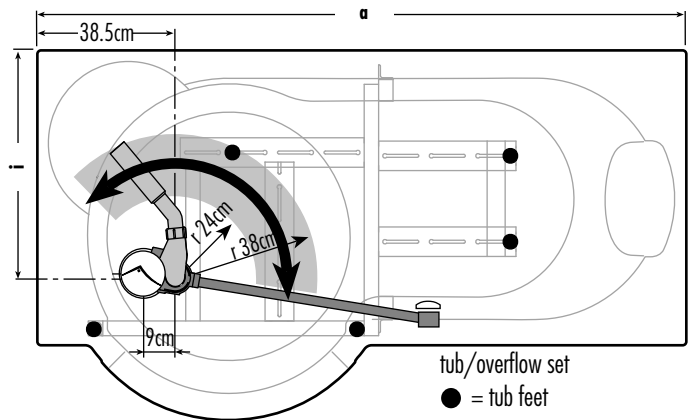
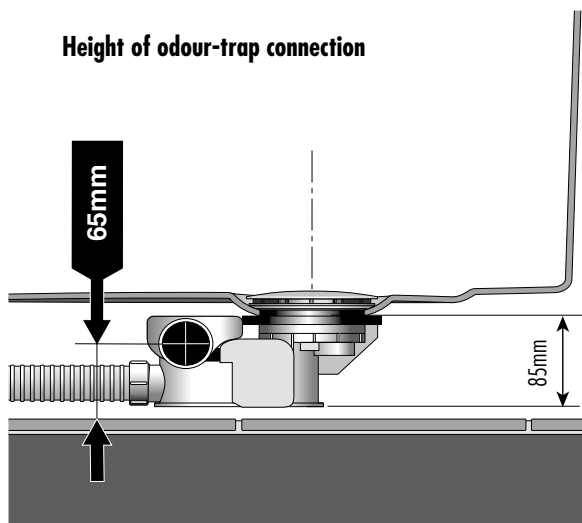

a	160	170	180	180 rounded
i	59	59	61	64

Artweger
TWIN:LINE

ARTWEGER TWINLINE 1 AIR / Coloured light



INSTALLATION - on completed floor

k	160	170	180	180 rounded
	50	50	55	55

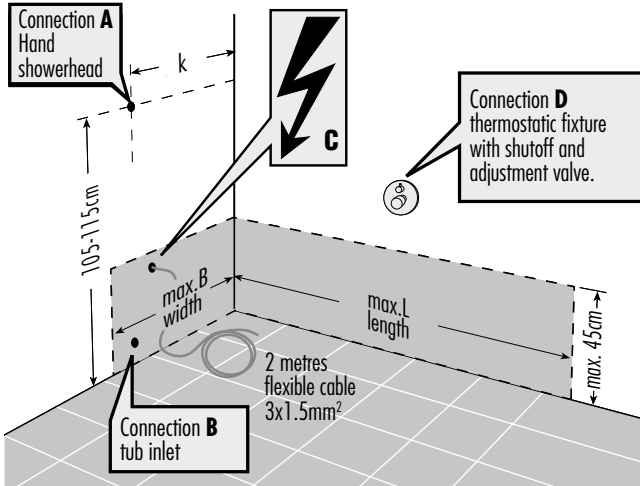

When installing the shower door on the already tiled wall a 0.8 cm compound bracket is required. Do not tile tub **before installation!**

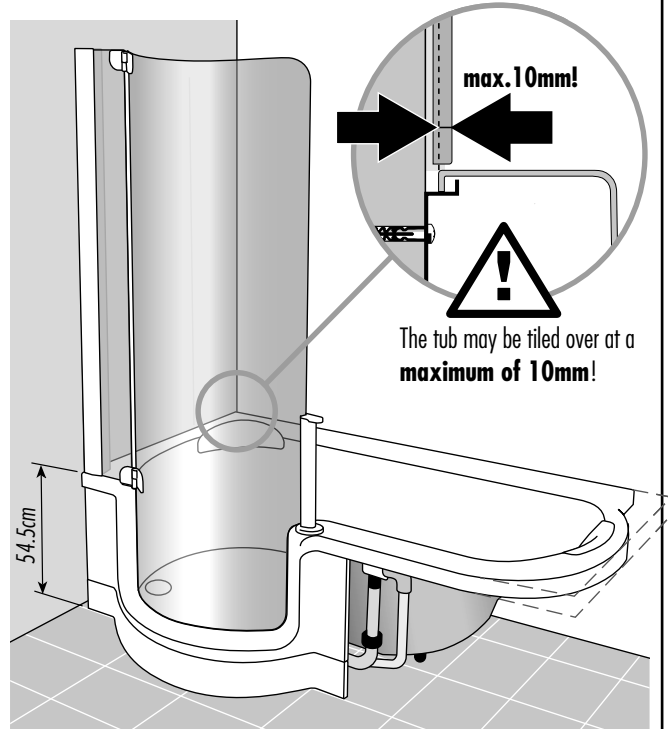

The area **under the tub** must also be **completely tiled!** However, the walls must not be tiled.

INSTALLATION ON STRAIGHT WALL - on completed floor

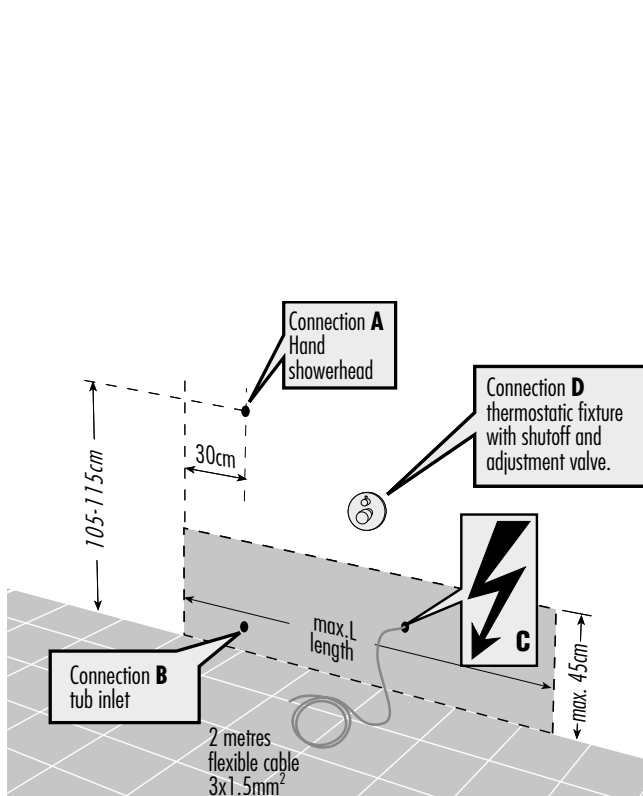

When installing the shower door on the already tiled wall a 0.8 cm compound bracket is required. Do not tile tub **before installation!**

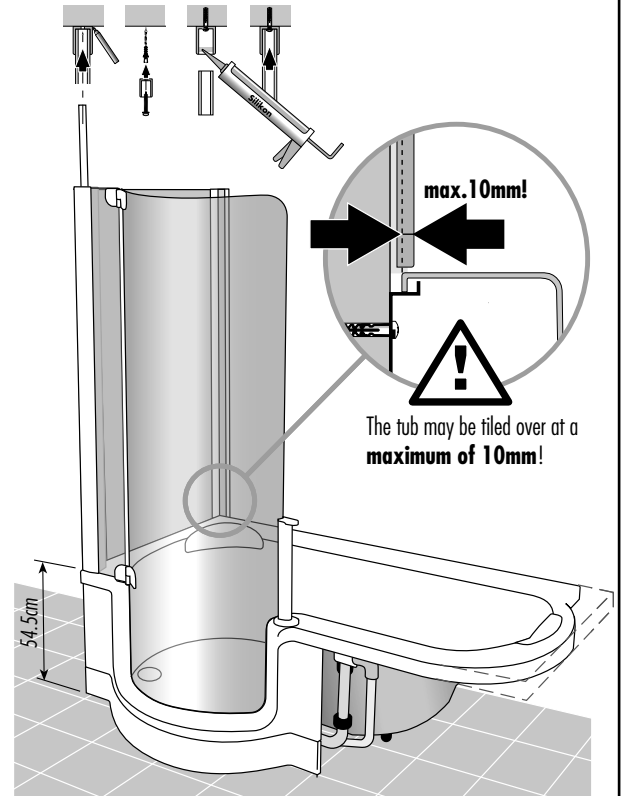

The area **under the tub** must also be **completely tiled!** However, the walls must not be tiled.

NOTES

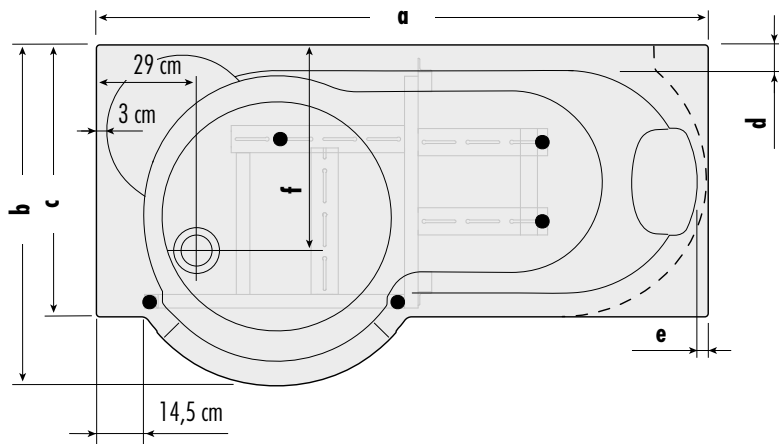

Total shower height	190/204,5
Room height required	+4,0
Entry height	17,5(11)
drain	50mm diam.

a	b	c	d	e	f	max.B	max.L
160	95	75	8,8	4	58	max.65	max.140
170	95	75	8,5	4	58	max.65	max.150
180	100	80	8	4	60,5	mac.70	max.160
180 rounded	100	80	13,5	4	63	max.70	max.160

**All dimensions
in cm!**

WIRING diagram

Possible combinations	Voltage	Maximum power
TWINLINE 1 Tub + Light	230V ~ 50Hz	7 Watt
TWINLINE 1 AIR	230V ~ 50Hz	50 Watt

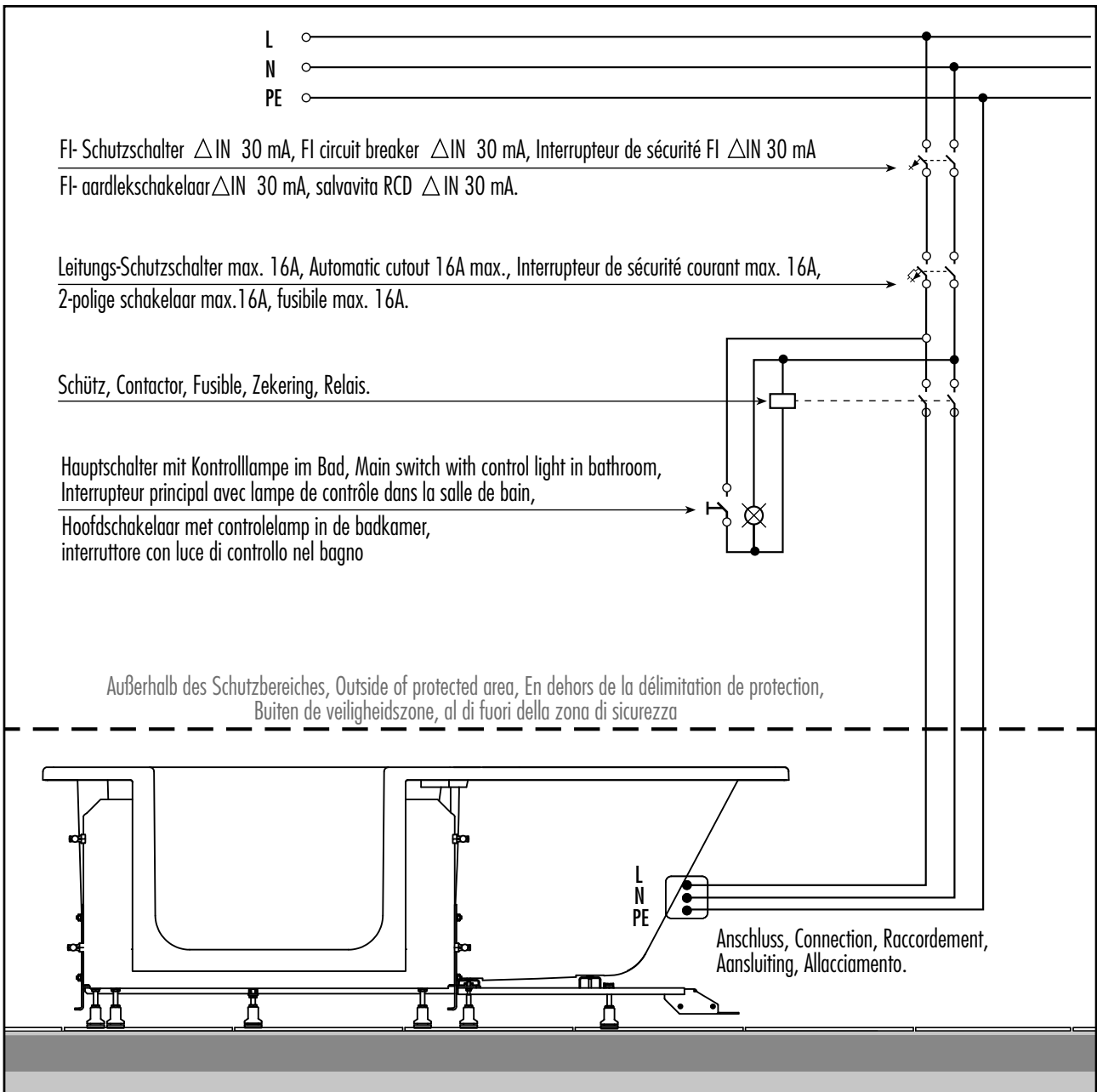

ARTWEGER TWINLINE 2



INSTALLATION - on completed floor

	160/75	170/75	170/80	180/80
k	55	55	60	60

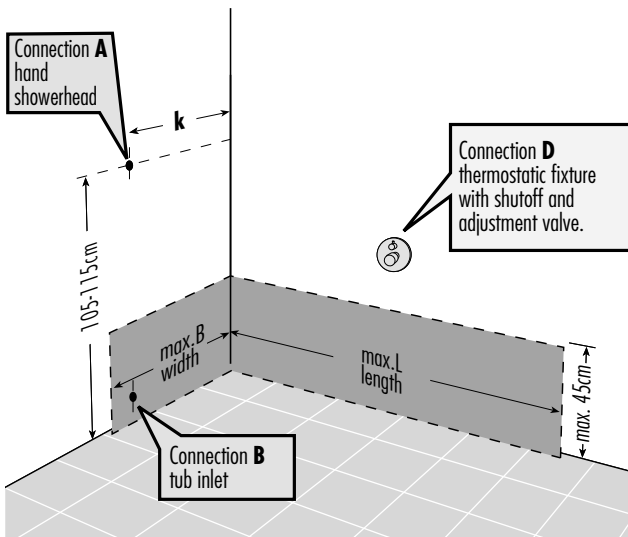

When installing the shower door on the already tiled wall a 1.2 cm compound bracket is required. Do not tile tub **before installation!**

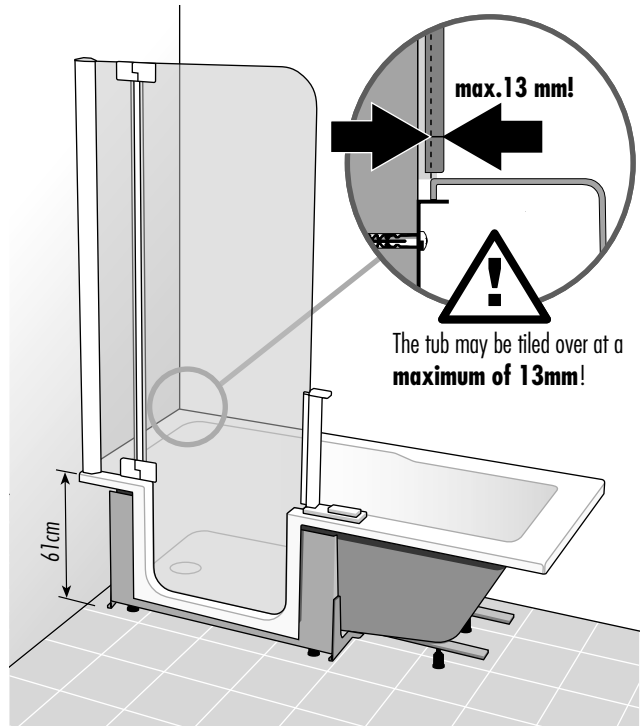

The area **under the tub** must also be **completely tiled!** However, the walls must not be tiled.

INSTALLATION ON STRAIGHT WALL - on completed floor

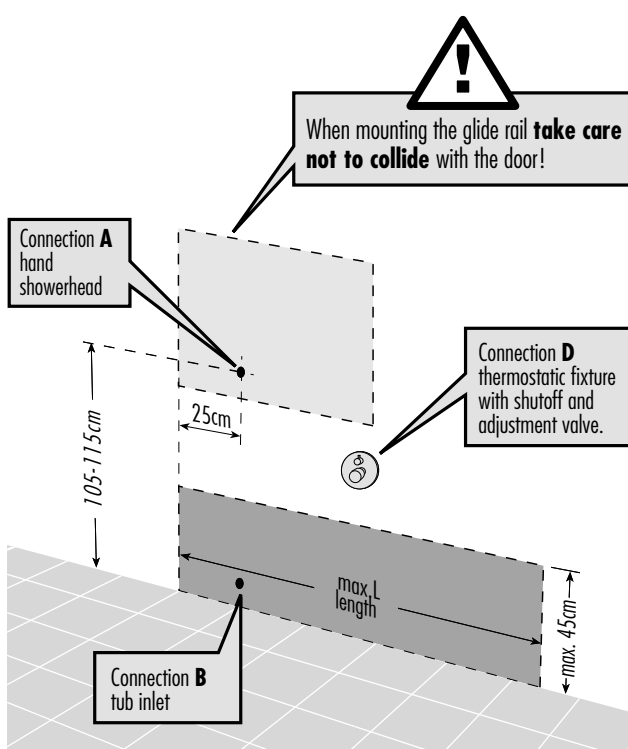

When installing the shower door on the already tiled wall a 1.2 cm compound bracket is required. Do not tile tub **before installation!**

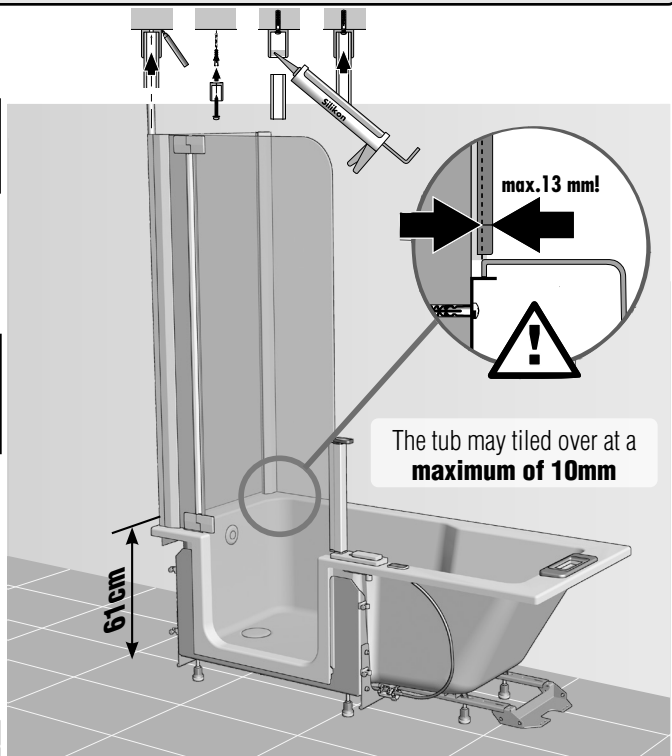

The area **under the tub** must also be **completely tiled!** However, the walls must not be tiled.

INSTALLATION - on raw concrete (casing dimensions)

Water (B) connections possible only within designated areas!

IMPORTANT! The dimensions of the casing must be observed exactly!

The tub can be set **exactly 13cm lower!**

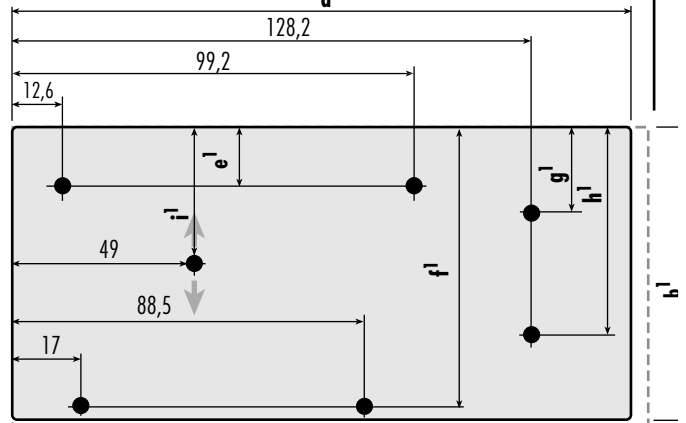
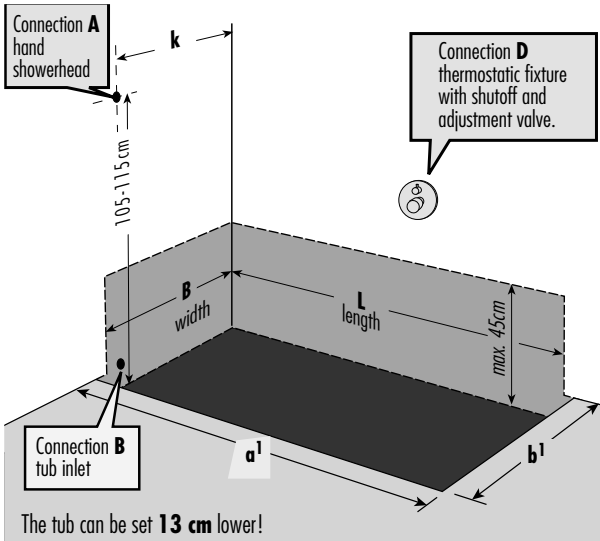

Twinline tub	a ¹	b ¹	e ¹	f ¹	g ¹	h ¹	i ¹
160x75	158	73,5	14,5	68,7	21,2	51	37,5
170x75	168	73,5	14,5	68,7	21,2	51	37,5
170x80	168	78,5	19,5	73,7	26,2	56	40
180x80	178	78,5	19,5	73,7	26,2	56	40

ODOUR-TRAP installation area

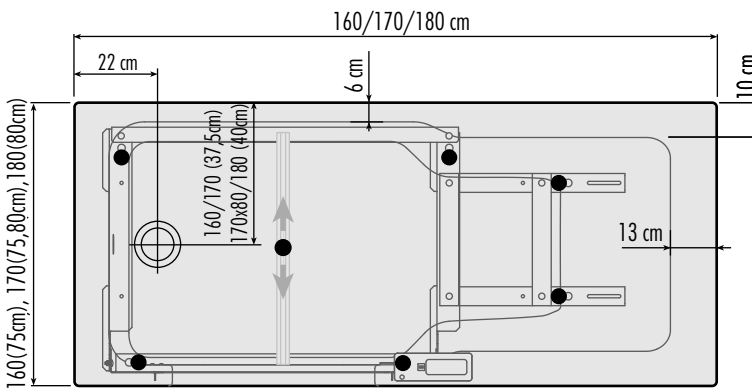

	B	L
160/75	70	155
170/75	70	165
170/80	75	165
180/80	75	175

Total shower height	211
Room height required	+4,0
Entry height	18,5
Drain	Ø50mm

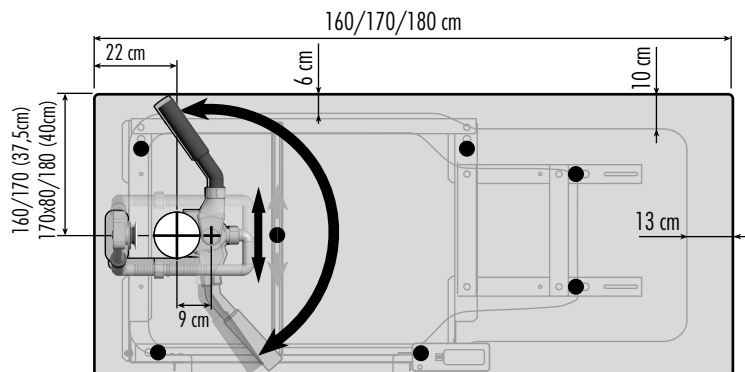
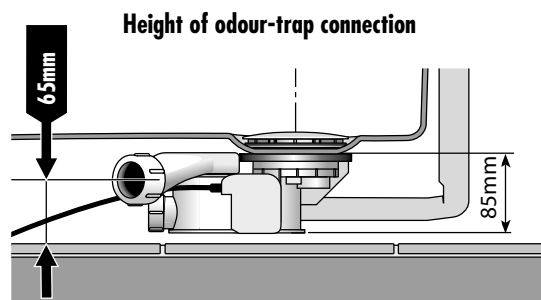

For installation on tiled walls

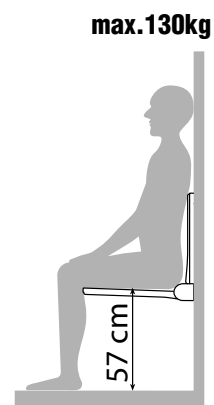
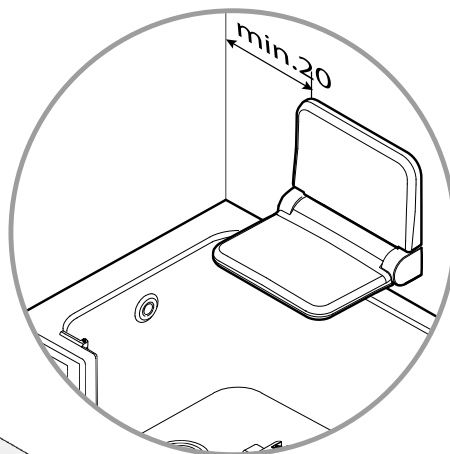
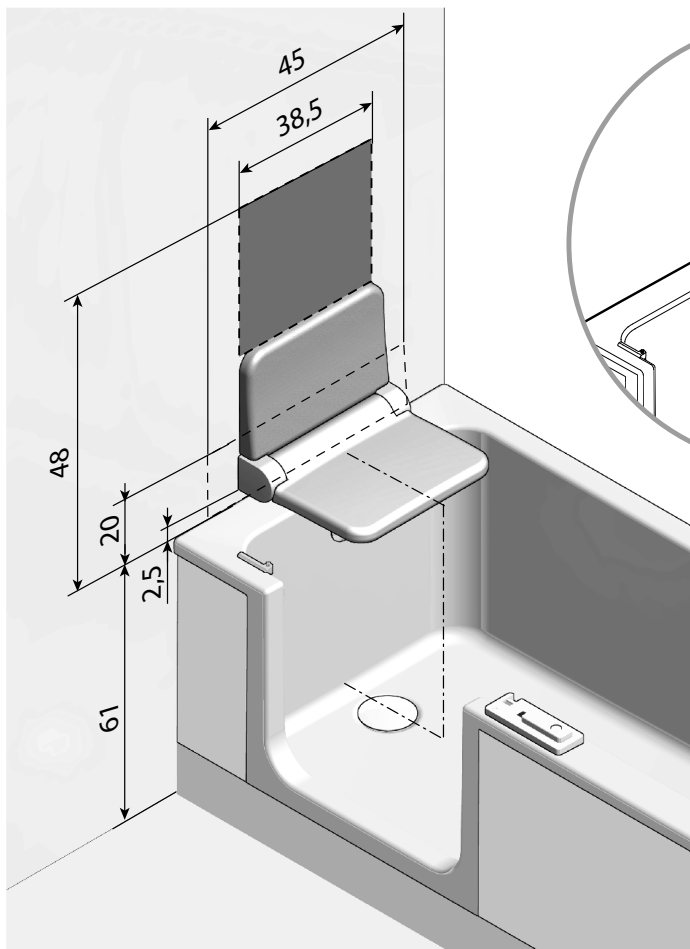

Checking the assembly positions.

*...dimensions from standing surface with seat height 57cm!



Free surface



Mounting area for seats.

A load-bearing wall must be present for attaching the seat!

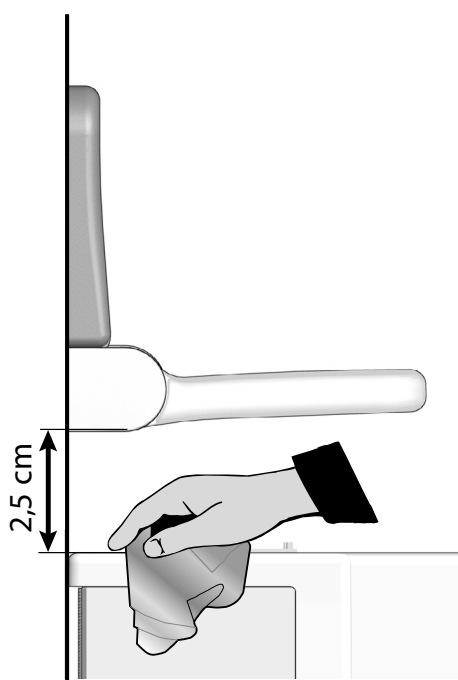

Artweger
TWIN:LINE

ARTWEGER TWINLINE 2 AIR / Coloured light



INSTALLATION - on completed floor

	160/75	170/75	170/80	180/80
k	55	55	60	60

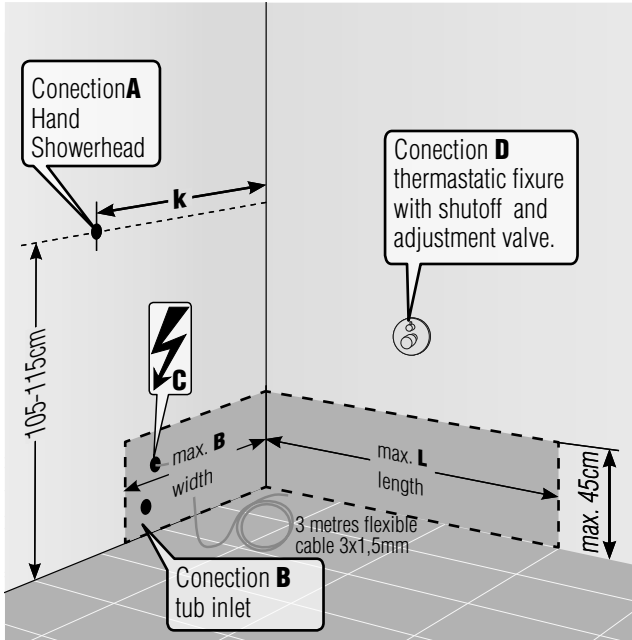

When installing the shower door on the already tiled wall a 1.2 cm compound bracket is required. Do not tile tub **before installation!**

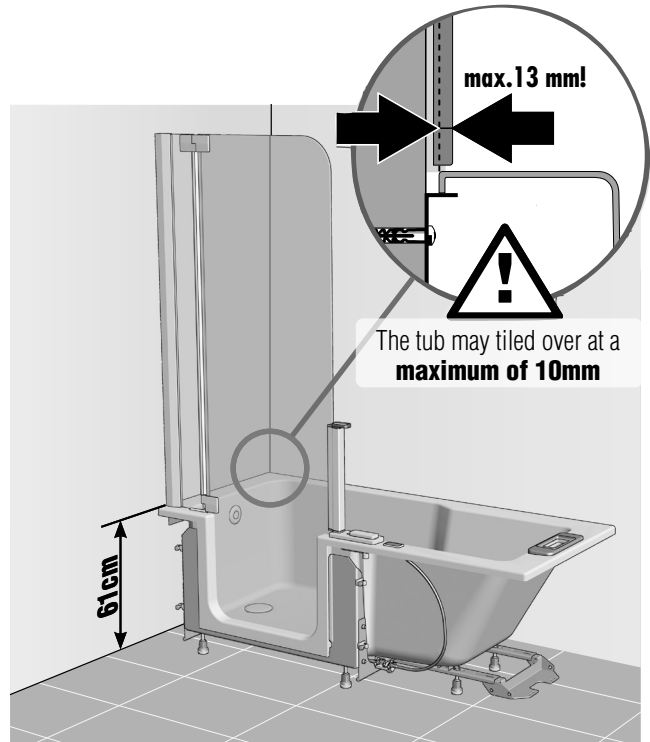

The area **under the tub** must also be **completely tiled!** However, the walls must **not be tiled**

INSTALLATION ON STRAIGHT WALL - on completed floor

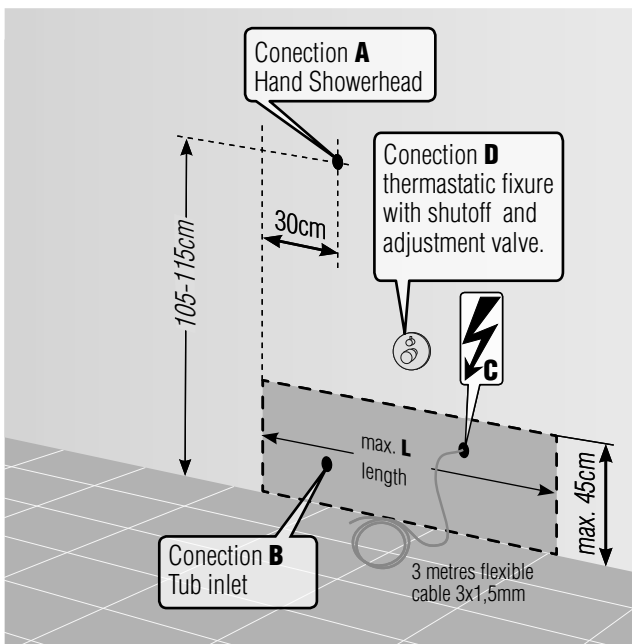

When installing the shower door on the already tiled wall a 1.2 cm compound bracket is required. Do not tile tub **before installation!**

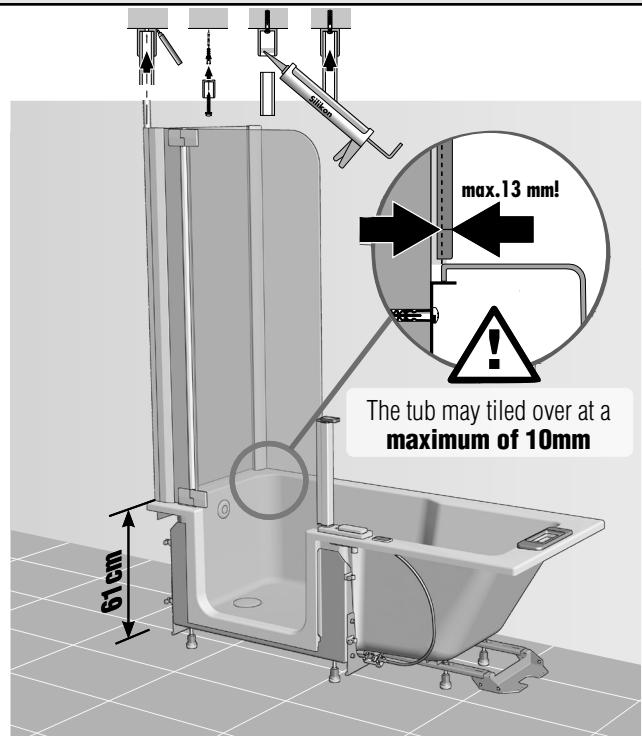

The area **under the tub** must also be **completely tiled!** However, the walls must **not be tiled**

ODOUR-TRAP installation area

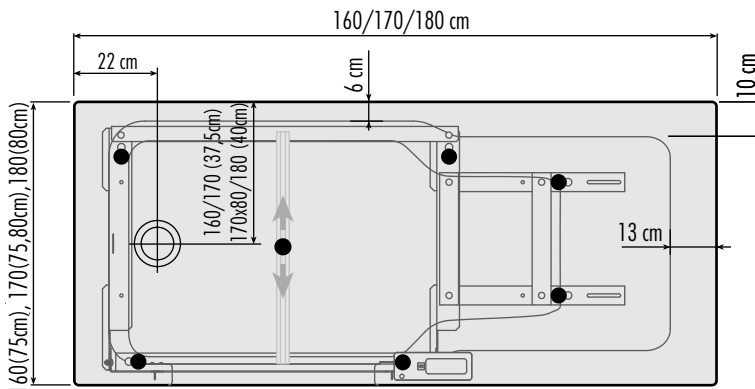

	B	L
160/75	70	155
170/75	70	165
170/80	75	165
180/80	75	175

Total shower height	211
Room height required	+4,0
Entry height	18,5
drain	50mm diam.

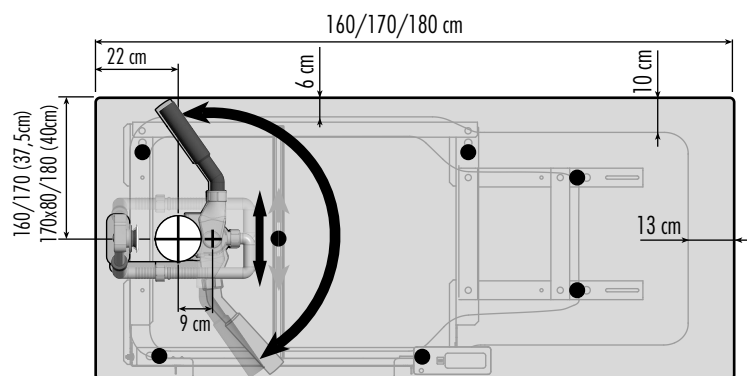
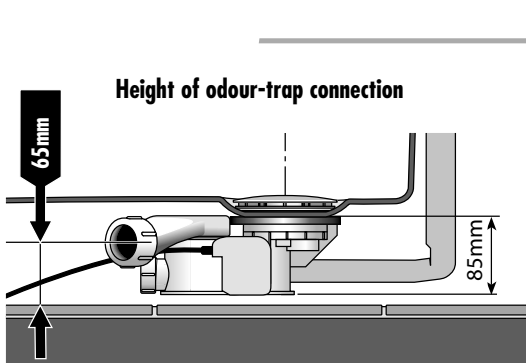

WIRING diagram

Possible combinations	Voltage	Maximum power
TWINLINE 2 Tub + Light	230V ~ 50Hz	7 Watt
TWINLINE 2 AIR	230V ~ 50Hz	50 Watt

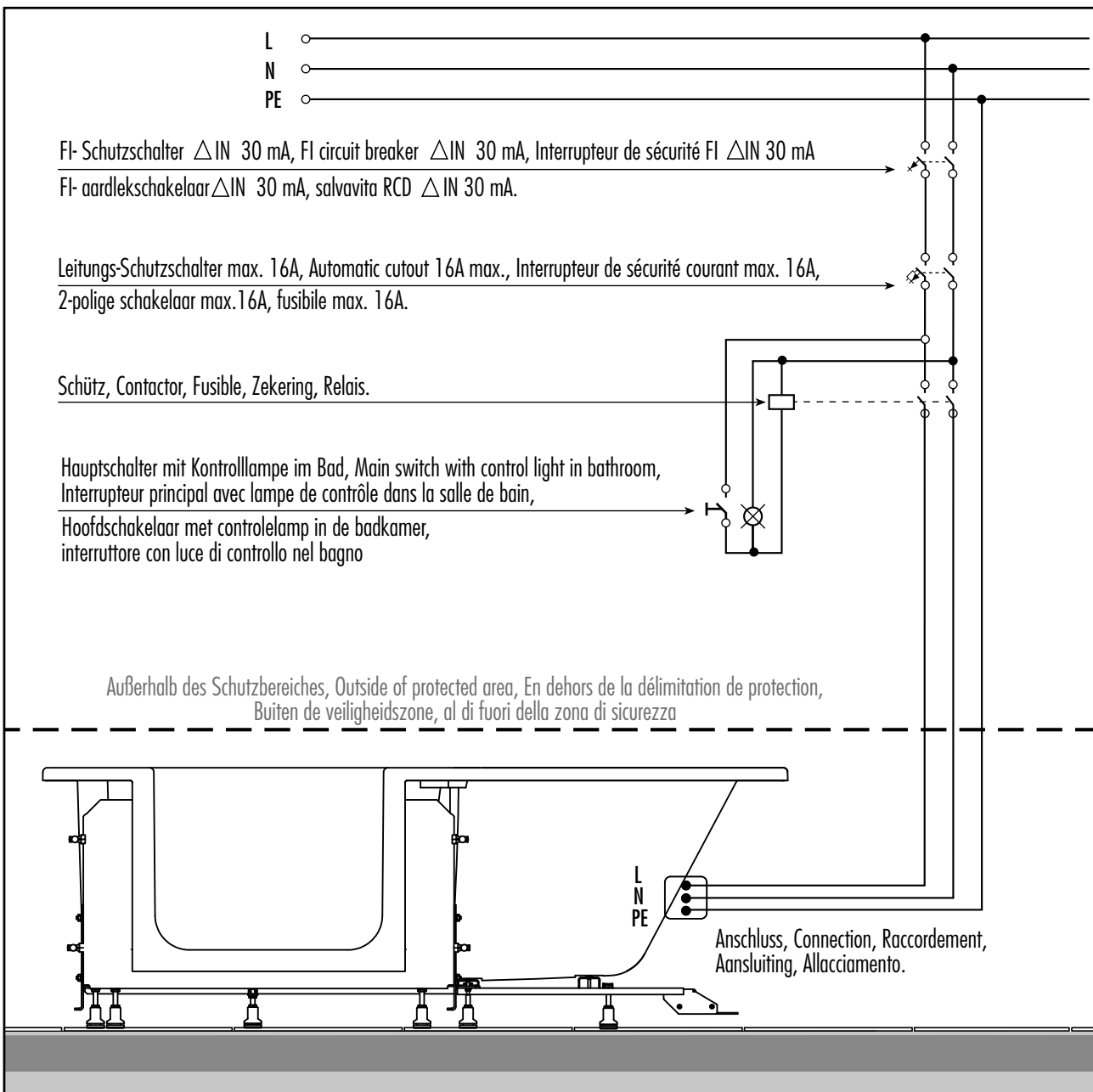

Artweger GmbH. & Co. KG

Sulzbacherstraße 60 | 4820 Bad Ischl | Austria
Tel. +43 6132 205-0 | Fax +43 6132 25034
info@artweger.at | www.artweger.at

Verkauf Deutschland

Artweger GmbH. & Co. KG
Postfach 1169 | 83402 Ainring | Deutschland
Tel. 0800 1114442-0 | Fax 0800 1114442-41
info@artweger.de | www.artweger.de

Verkauf Schweiz

Artweger GmbH. & Co. KG
Postfach 16 | CH-4202 Duggingen
Tel. + 41 61 751 90 91
info@artweger.com | www.artweger.com



Druck- und Satzfehler sowie technische Änderungen vorbehalten.
Typographical errors and technical changes reserved.
Sous réserve d'erreurs d'impression ou de syntaxe ainsi que de modifications techniques.
Drukfouten, maatwijzingen en technische veranderingen voorbehouden.
Ci riserviamo errori di stampa e variazioni di misure e specifiche tecniche.