

MONTAGEANLEITUNG

ZWEITEILIGE SCHIEBETÜR, gerahmt

9 G 5 S...

ASSEMBLY INSTRUCTIONS

TWO PART - SLIDING DOOR, with frame

NOTICE DE MONTAGE

PORTE COULISSANTE À 2 PANNEAUX, avec cadre

MONTAGEVOORSCHRIFT

2 - DELIGE SCHUIFDEUR, met profiel

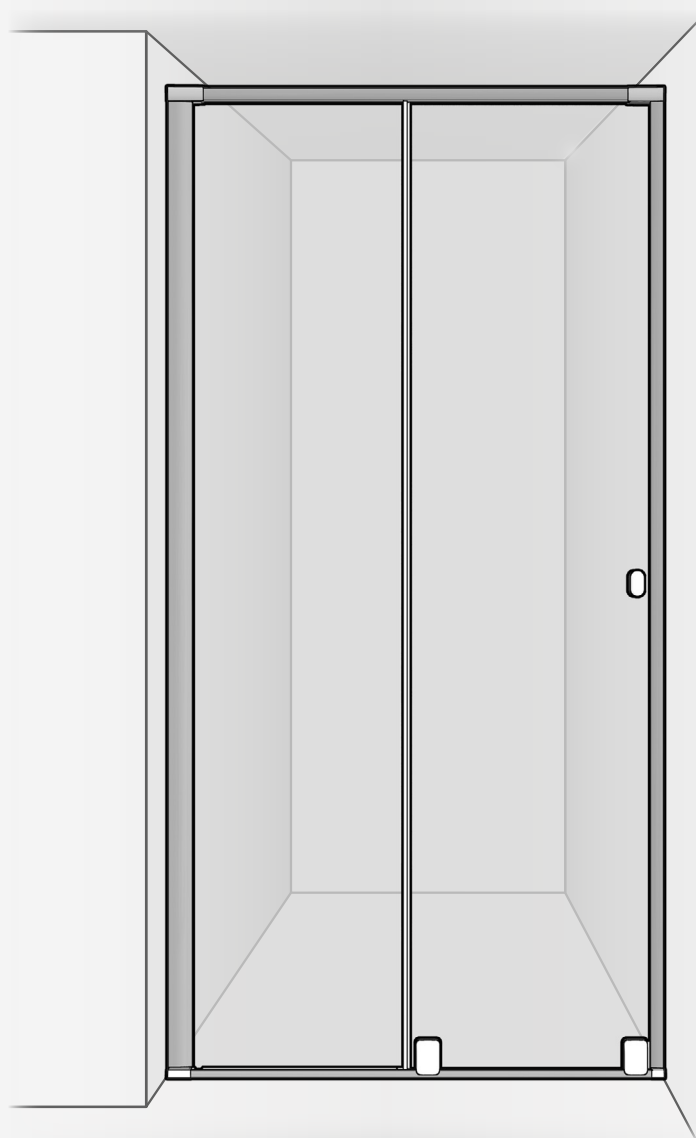

Vor Gebrauch sorgfältig lesen! Zum Nachschlagen und Aufbewahren dem Endkunden übergeben!

Read carefully before use! Hand over to the customer for looking up and storage!

Avant emploi lire soigneusement! Remettez le au client pour la recherche et le stockage!

Voordien gebruik zorgvuldig lezend! Overhandig de klant voor het kijken omhooggaand en opslag!

DEUTSCH
Originalsprache

ENGLISH
Translation

FRANCAIS
Traduction

NEDERLANDS
Vertaling

INHALTSVERZEICHNIS	OVERVIEW
INHALTSVERZEICHNIS2	OVERVIEW2
SICHERHEITS-HINWEISE.....4	SAFETY INSTRUCTIONS4
BENÖTIGTES WERKZEUG6	NECESSARY TOOLS6
MONTAGESET6	ASSEMBLY KIT6
MONTAGESET7	ASSEMBLY KIT7
MONTAGEVARIANTEN8	ASSEMBLY VARIATIONS8
VERSTELLBEREICH.....8	ADJUSTMENT RANGE8
MONTAGEVARIANTEN9	ASSEMBLY VARIATIONS9
WANNEN- EINBAUMASS9	TRAY INSTALLATION MEASUREMENT9
MONTAGE10	ASSEMBLY10
» MONTAGE FIXTEIL14	» INSTALLATION OF IMMOVABLE ELEMENT14
» MONTAGE TÜR.....16	» INSTALLATION DOOR.....16
» MONTAGE GRIFF16	» INSTALLATION OF HANDLE16
MONTAGEVARIANTEN17	ASSEMBLY VARIATIONS17
MONTAGE19	ASSEMBLY19
» MONTAGE DICHTLEISTEN19	» INSTALLATION OF SEALING STRIP19
» MONTAGE TÜR.....21	» INSTALLATION DOOR.....21
ABDICHTEN MIT SANITÄRSILIKON24	SEALING WITH SANITARY SILICONE24
» TÜR JUSTIEREN.....26	» ADJUST DOOR.....26
ERSATZTEILE31	SPARE PARTS.....31
 Montageanleitung für Einbau LINKS - bei Einbau RECHTS - spiegelgleicher Aufbau.	 Assembly instructions for installation LEFT - for installation RIGHT - assemble in mirror image.

VUE D'ENSEMBLE	OVERZICHT
VUE D'ENSEMBLE3	OVERZICHT3
INSTRUCTIONS SÉCURIT4	VEILIGHEIDS VOORSCHRIFTEN4
OUTILLAGE NECESSAIRE6	BENODIGD GEREEDSCHAP6
SET DE MONTAGE.....6	MONTAGESET6
SET DE MONTAGE.....7	MONTAGESET7
VARIANTES DE MONTAGE8	MONTAGEVARIANTEN8
POSITIONNEMENT8	VERSTELBAARHEID.....8
VARIANTES DE MONTAGE9	MONTAGEVARIANTEN9
MESURES POUR MONTAGE SUR RECEVEUR.....9	DOUCHEBAK- INBOUWMAAT.....9
MONTAGE 10	MONTAGE 10
» MONTAGE PARTIE FIXE 14	» MONTAGE VAST DEEL 14
» MONTAGE DE LA PORTE 16	» MONTAGE DEUR..... 16
» MONTAGE POIGNÉE..... 16	» MONTAGE GREEP 16
VARIANTES DE MONTAGE 17	MONTAGEVARIANTEN 17
MONTAGE 19	MONTAGE 19
» MONTAGE BAGUETTES D'ÉTANCHÉITÉ 19	» MONTAGE AFDICHTINGEN 19
» MONTAGE DE LA PORTE 21	» MONTAGE DEUR..... 21
ETANCHER AVEC DU SILICONE SANITAIRE.....24	AFDICHTEN MET SANITAIR-SILICONEN.....24
» AJUSTEZ DE LA PORTE 26	» DEUR AAN TE PASSEN..... 26
PIÈCES DÉTACHÉES31	ONDERDELEN31

C'est prévue pour une installation à GAUCHE –
en cas d'une installation à DROITE -A inverser pour partie fixe en GAUCHE.

Montagevoorschrift voor inbouw LINKS -
bij inbouw RECHTS - montage in spiegelbeeld.

SICHERHEITS-HINWEISE

SAFETY INSTRUCTIONS

INSTRUCTIONS SÉCURIT

VEILIGHEIDS VOORSCHRIFTEN

DE Vor dem Einbau bitte unbedingt beachten!

- Produkt **vor dem Einbau**, auf Richtigkeit, Beschädigungen und das Zubehör auf Vollständigkeit **überprüfen**.
- **Bei sichtbarem Schaden Produkt keinesfalls einbauen!**
- **Beachten Sie beim Hantieren das teilweise hohe Gewicht und/oder die großen Abmessungen von Einzelteilen.**
- **Beachten Sie beim Bohren der Löcher, dass Sie keine Leitungen (Elektro, Gas, Wasser) beschädigen.**



Unsere Haftung beschränkt sich alleine auf unsere Produkte und kann daher nicht auf den Ein- und Ausbau ausgedehnt werden. Die Kosten für einen nachträglichen Aus- und Einbau eines Produkts und die damit verursachten Schäden sind **kein** Bestandteil der Garantie.

EN Please note carefully before installing

- Before installing, check for correctness and damage and the accessories for completeness.
- **Do not under any circumstances install product with visible damage!**
- **Take the great weight and/or the large dimensions into consideration when handling individual parts!**
- **When drilling holes do not damage hidden pipes and wiring.**

Our liability is limited to our products alone and therefore cannot be extended to installation and dismantling. Costs for subsequent dismantling and installation of a product and damage caused thereby are not part of the guarantee.

FR A respecter impérativement avant le Montage

- Avant le montage de vérifier qu'il s'agit du bon modèle, qu'elle n'est pas endommagée et que les accessoires sont complets.
- **En cas de dommages visibles, ne pas monter le produit!**
- **Lors de la manutention, merci de prêter attention au poids parfois très élevé et/ou aux dimensions de certaines pièces!**
- **Faites attention en perçant les trous de ne pas endommager les tuyauteries (cables électriques, canalisations de gaz, d'eau, etc).**

Notre responsabilité se limite à nos produits et ne peut être étendue sur l'installation et le démontage. Les coûts générés lors d'un démontage après installation et d'une ré-installation d'un produit et les dommages qui en résultent ne pourront être pris en charge par la garantie.

NL Voor inbouw beslist in acht nemen!

- Bad voor het inbouwen op juistheid, beschadigingen en toebehoren op volledigheid controleren.
- **Bij zichtbare beschadiging product in geen geval inbouwen!**
- **Let u bij het gebruik om het gedeeltelijk grote gewicht en/of de grote afmetingen van enkele onderdelen!**
- **bij het boren van gaten er op letten, dat U geen leidingen (elektro, gas of water) beschadigt!**

Wanneer het bad betegeld wordt, beslist de inbouwmaten van de badkuip en van de doucheafscheiding in acht nemen. Onze aansprakelijkheid is beperkt tot onze producten en kan daarom niet op de in- en uitbouw uitgebreid worden. De kosten voor een latere uit- en inbouw van een product en de daaruit voortvloeiende schade zijn geen onderdeel van de garantie.



DE ACHTUNG! Beim Hantieren mit Glas Schutz- kleidung tragen!

Bitte untersuchen Sie nach dem Auspacken das Einscheiben-Sicherheitsglas (ESG) unverzüglich auf mögliche Transportschäden, wie abgesprungene Kanten oder Ecken. Wird ein Schaden festgestellt bitte umgehend Schadensmeldung machen und die Scheibe nicht einbauen, da dieser Fehler auch später zu einem Bruch führen kann! Alle Gläser werden vor dem Verpacken sorgfältig kontrolliert. Spätere Reklamationen, auch bei Bruch, können daher nicht anerkannt werden.

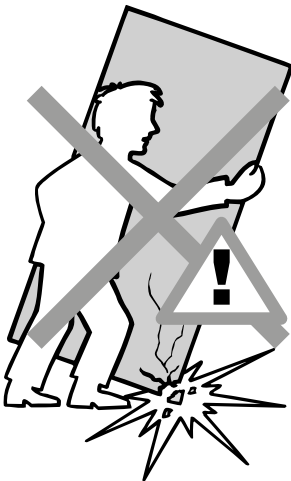

EN ATTENTION! Wear protective clothing when handling glass!

Please examine the single-pane safety glass for possible transport damage such as chipped edges or corners immediately after unpacking. If damage is detected do not install the pane because a defect can lead to breakage later! Please make a damage report without delay! All glass panes are controlled with utmost care before packing. Therefore later complaints cannot be acknowledged, even in case of breakage.

FR ATTENTION ! Portez des vêtements protecteurs en manipulant du verre.

Merci de vérifier immédiatement le verre de sécurité monofeuille au déballage sur d'éventuels dommages survenus au transport, tels que chants et angles écaillés. Si toutefois un défaut a été constaté, merci d'en faire la déclaration au plus vite et ne pas monter la vitre, car ce défaut peut être, par la suite, à

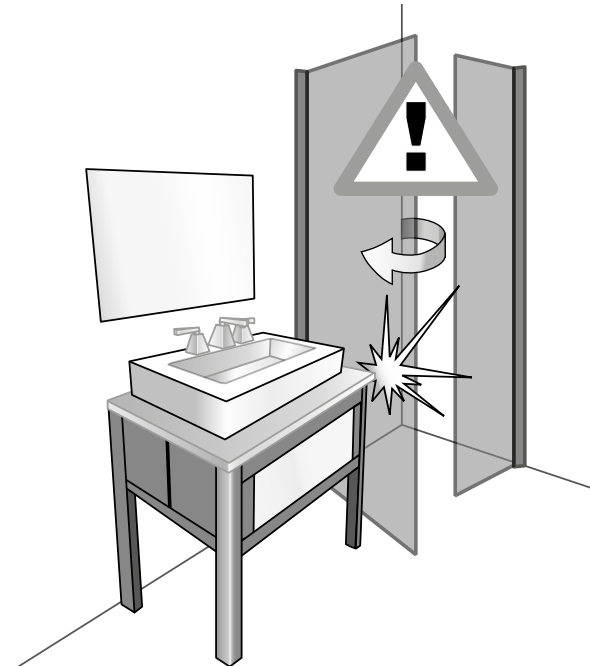

l'origine d'une casse! Tous les verres sont contrôlés minutieusement avant le conditionnement. Pour cette raison, aucune réclamation ultérieure, même en cas de casse, ne pourra être prise en compte.

Na het uitpakken het enkel veiligheidsglas (ESG) onmiddellijk op mogelijke transport- beschadigingen, zoals afgesprongen kanten of hoeken, controleren. Wordt een beschadiging vastgesteld, dan mag het glas niet worden ingebouwd, omdat deze schade ook later tot een breuk kan leiden! Bij een vastgestelde schade, meldt dit onmiddellijk! Al het glas wordt voor het verpakken zorgvuldig gecontroleerd. Latere reclames, ook bij breuk, kunnen daarom niet geaccepteerd worden.

NL ATTENTIE ! Bij het hanteren van glas be- schermde kle- ding dragen!

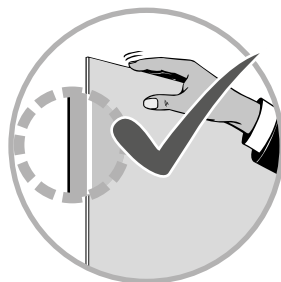

BENÖTIGTES WERKZEUG	NECESSARY TOOLS	OUTILLAGE NECESSAIRE	BENODIGD GEREEDSCHAP
---------------------	-----------------	----------------------	----------------------

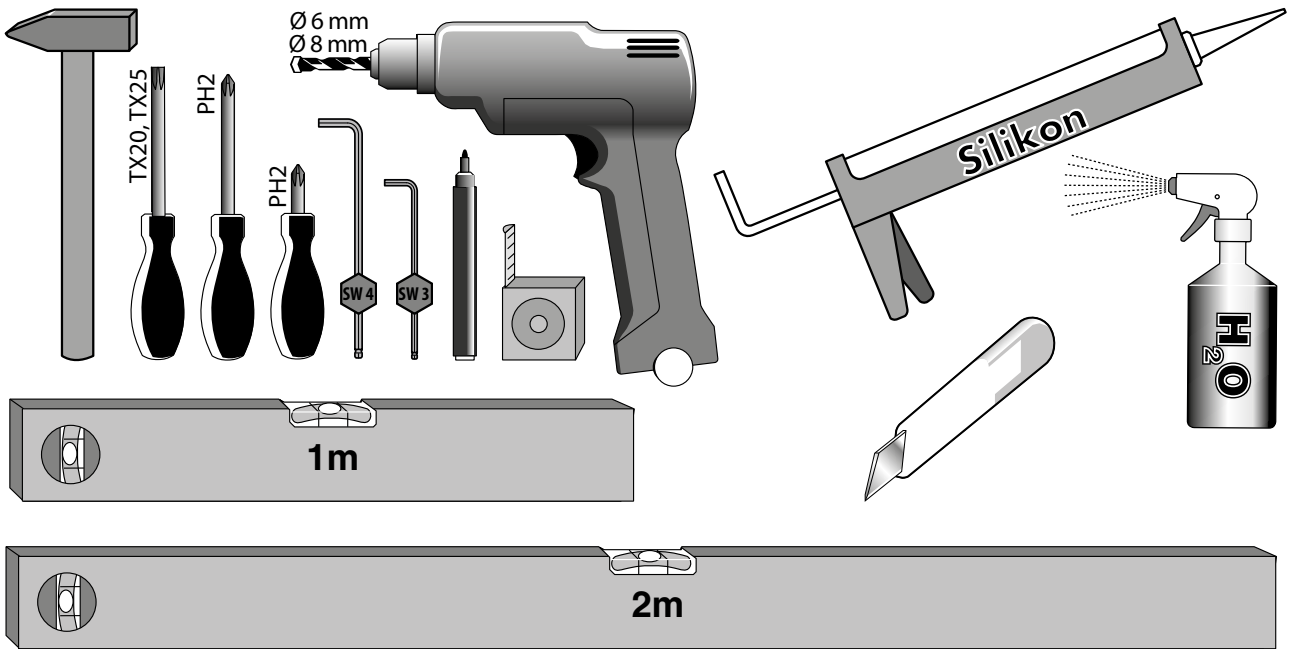

MONTAGESET	ASSEMBLY KIT	SET DE MONTAGE	MONTAGESET
------------	--------------	----------------	------------

1x

MatNr: 705650

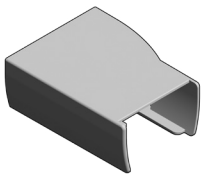

1x

MatNr: 705651

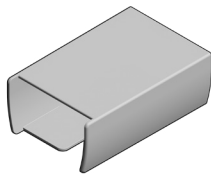

1x

MatNr: 705655

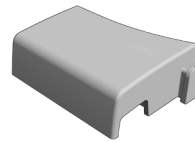

1x

MatNr: 705659

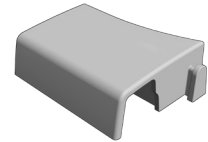

2x

MatNr: 705652



1x

MatNr: 705656

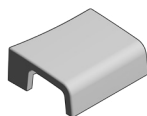

1x

MatNr: 705660

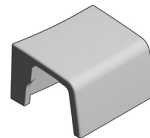

1x



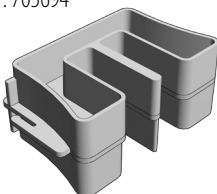





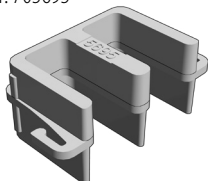

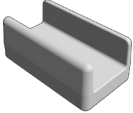
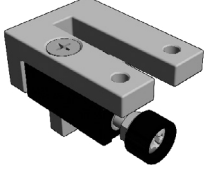
MatNr: 705694

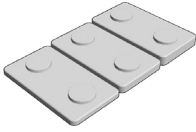
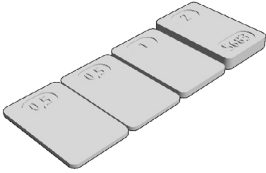
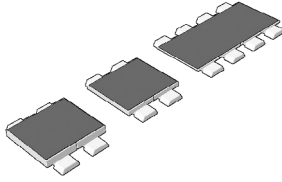
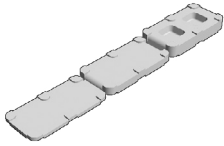

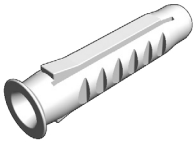
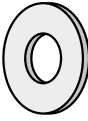
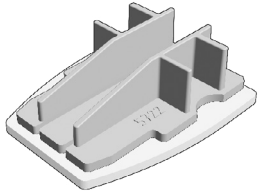
1x

MatNr: 705695

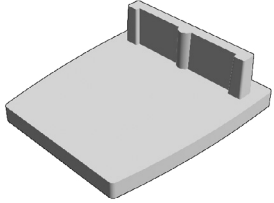

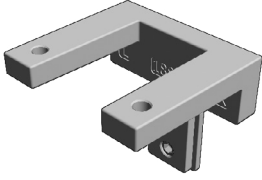
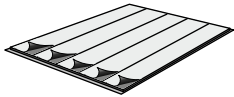
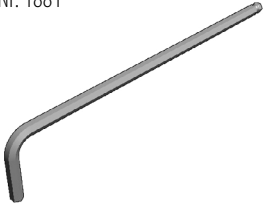
MONTAGESET	ASSEMBLY KIT	SET DE MONTAGE	MONTAGESET
<p>1x MatNr: 705684</p> 	<p>1x MatNr: 809G05L</p> 	<p>1x MatNr: 705693</p> 	<p>3x M5 × 10 mm MatNr: 24194</p> 
<p>2x MatNr: 705681</p> 	<p>2x MatNr: 705683</p> 	<p>1x MatNr: 809G06</p> 	<p>1x MatNr: 709510</p> 
<p>5x 4,8 × 60 mm MatNr: 24466</p> 	<p>5x Ø 8 mm MatNr: 24409</p> 	<p>10x MatNr: 2430</p> 	<p>1x MatNr: 809G07</p> 
<p>2x MatNr: 705723</p> 	<p>5x 4,2x38mm MatNr: 24467</p> 	<p>5x Ø 6mm MatNr: 24410</p> 	<p>1x MatNr: 705674</p> 
<p>2x MatNr: 705675</p> 	<p>1x MatNr: 809G02L</p> 	<p>1x (5 Stk.) MatNr: 10150</p> 	
<p>1x SW 2,5 MatNr: 1881</p> 			

MONTAGEVARIANTEN

ASSEMBLY VARIATIONS

VARIANTES DE MONTAGE

MONTAGEVARIANTEN

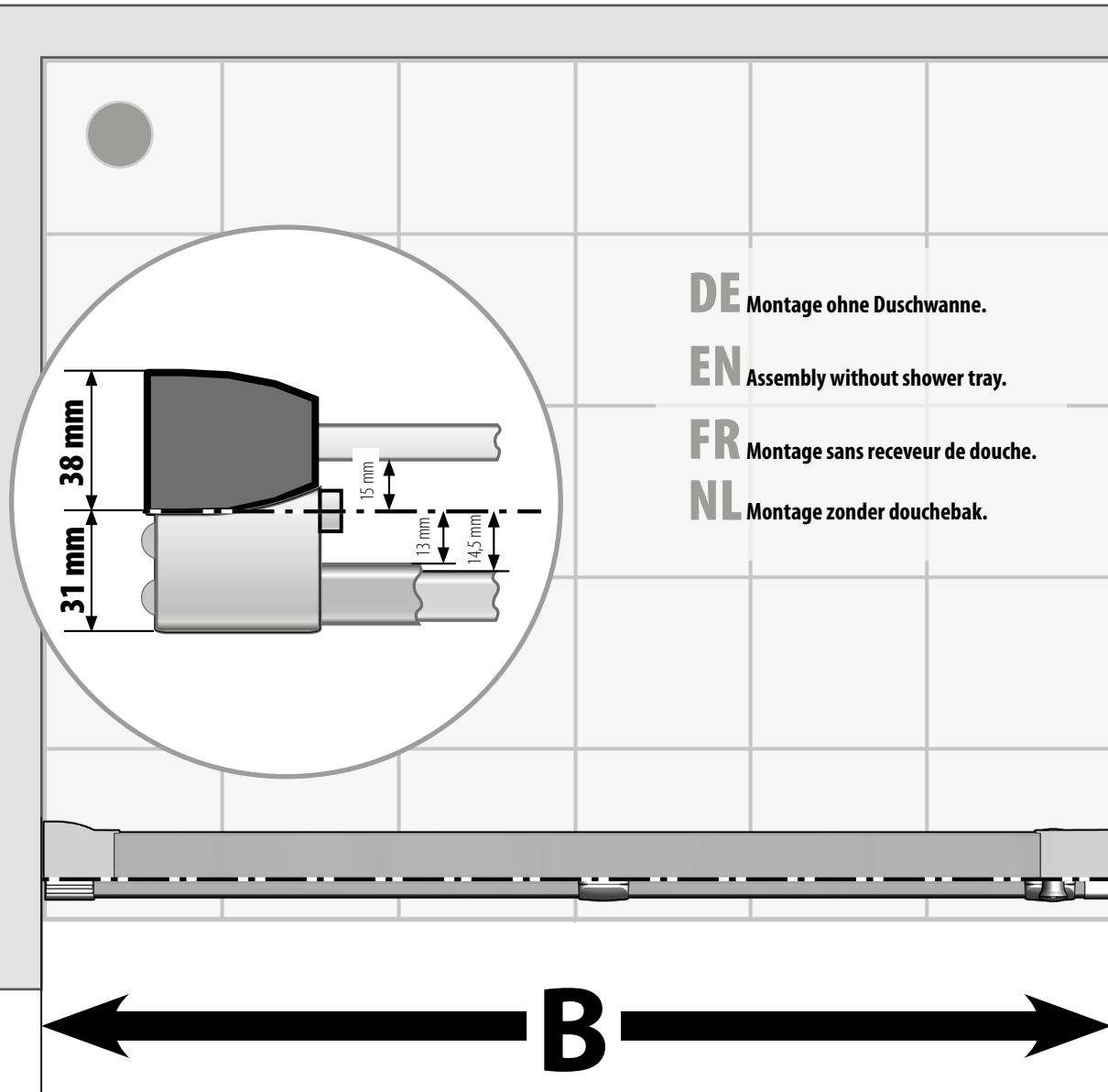

DE Montage ohne Duschwanne.

EN Assembly without shower tray.

FR Montage sans receveur de douche.

NL Montage zonder douchebak.

VERSTELLBEREICH

ADJUSTMENT RANGE

POSITIONNEMENT

VERSTELBAARHEID

Auftrag Nr.: /

Sondergrößen • special sizes • mesures spéciales • speciale maten

B= mm

Serie

B

1000

990 ± 20mm

1200

1190 ± 20mm

1400

1390 ± 20mm

1600

1590 ± 20mm

MONTAGEVARIANTEN

ASSEMBLY VARIATIONS

VARIANTES DE MONTAGE

MONTAGEVARIANTEN

DE Montage auf Duschwanne.

FR Montage sur un receveur de douche.

EN Assembly on shower tray.

NL Montage op douchebak.

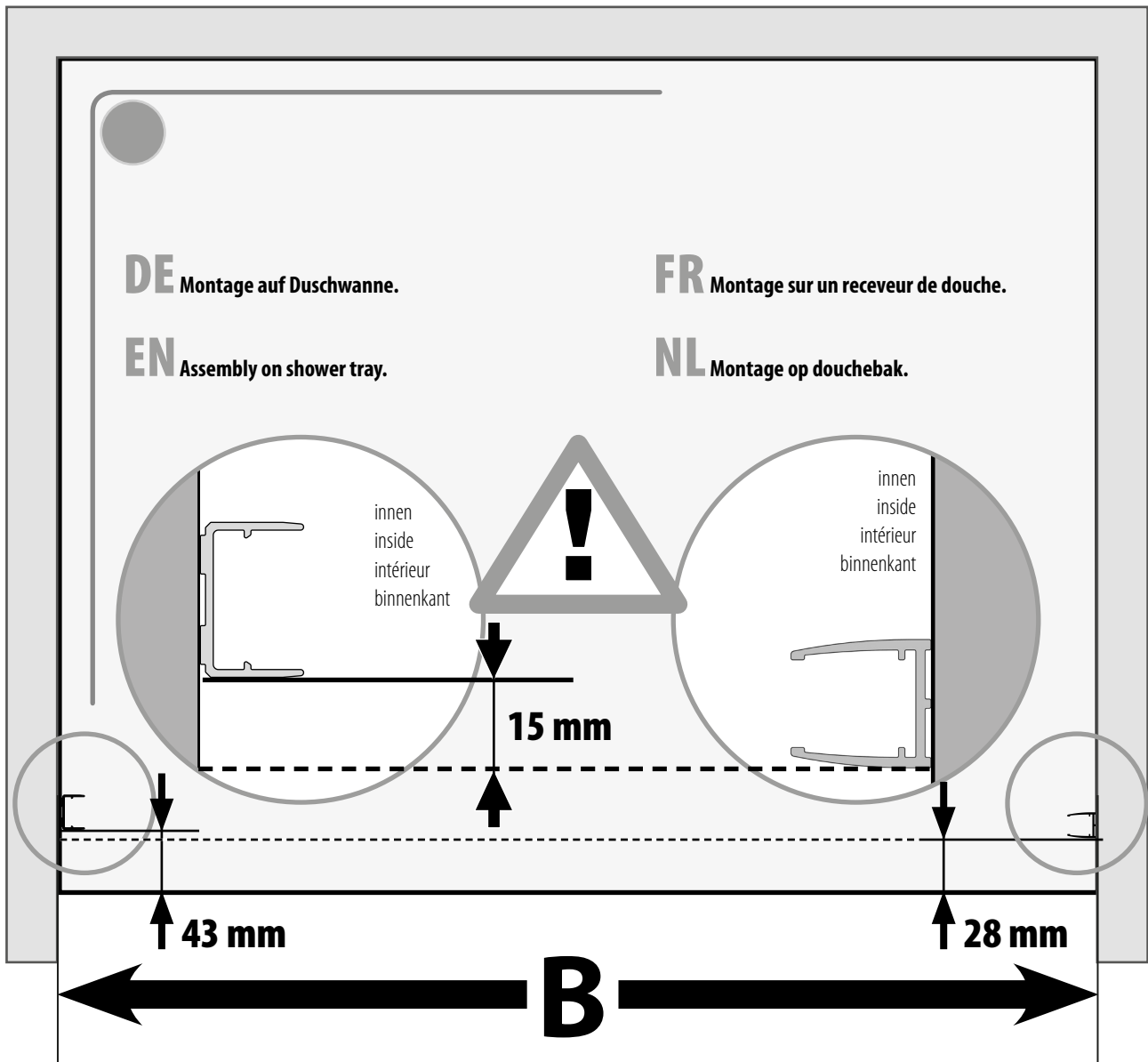

WANNEN-
EINBAUMASS

TRAY INSTALLATION
MEASUREMENT

MESURES POUR MONTAGE
SUR RECEVEUR

DOUCHEBAK-
INBOUWMAAT

Serie		
1000	970 - 1010mm	
1200	1170 - 1210mm	
1400	1370 - 1410mm	
1600	1570 - 1610mm	

1

DE ACHTUNG! Eine **einwandfreie** Montage ist nur möglich wenn der Boden **waagrecht** und die Wände **senkrecht** sind. Bei Bedarf beiliegende **Unterlagsplättchen** verwenden!

EN Attention: Correct installation is only possible if the floor is horizontal and the walls are vertical. If needed use the enclosed spacing plates!

FR Attention: Un montage impeccable n'est possible que si le sol est parfaitement plan et le murs droits. En cas de besoin utiliser les cales fournies !

NL Let op: Een perfecte montage is alleen mogelijk, als de bodem horizontaal en de wanden verticaal t.o.v. elkaar staan. Indien nodig, bijgevoegde onderlegplaatjes gebruiken.

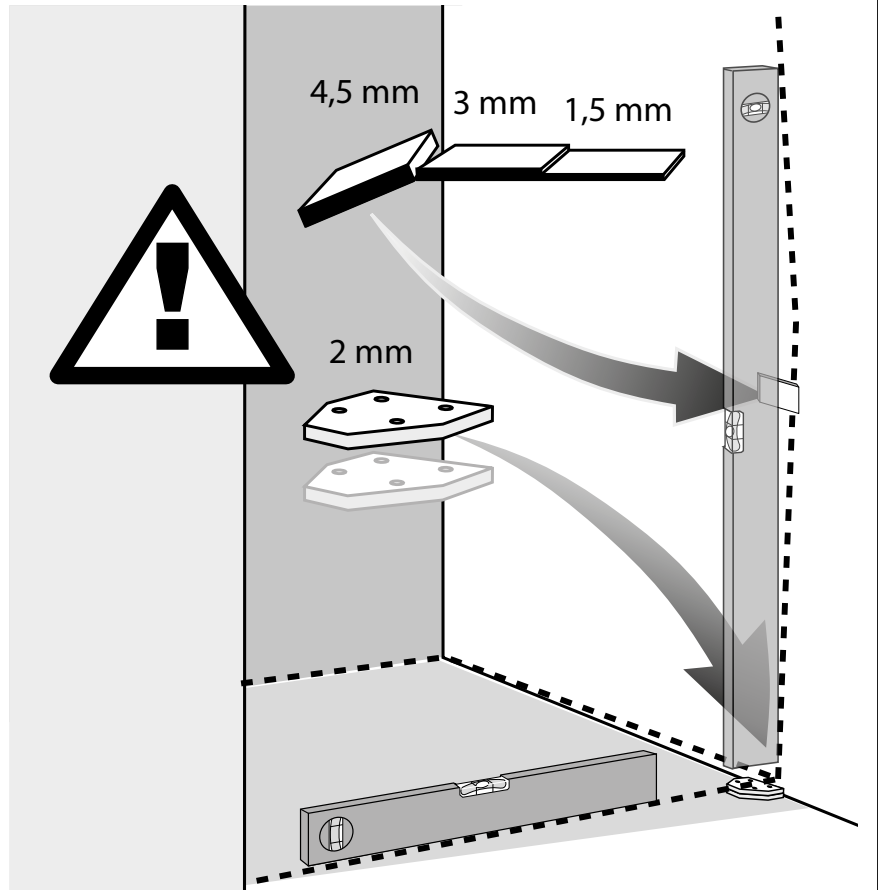

2

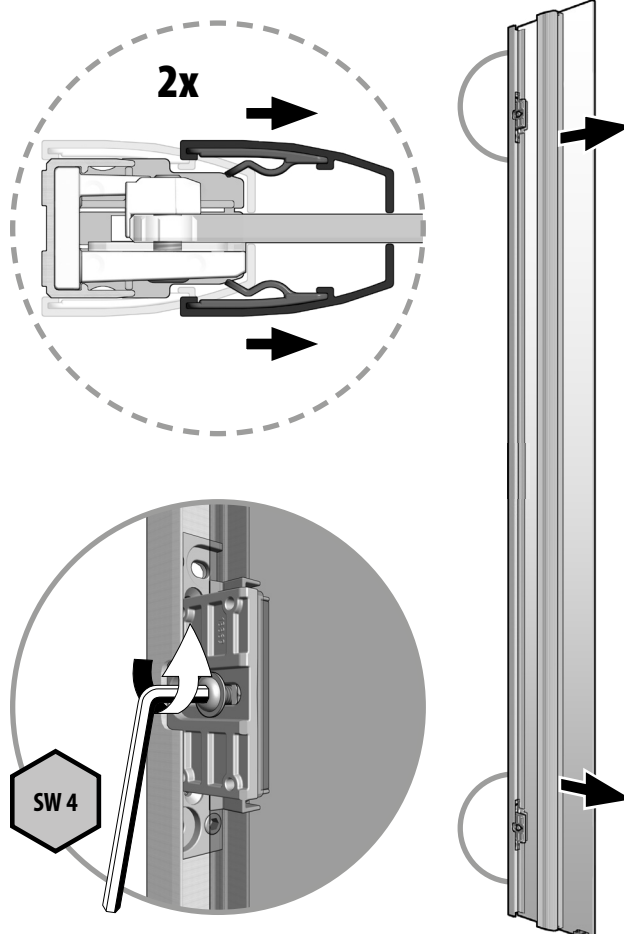

3

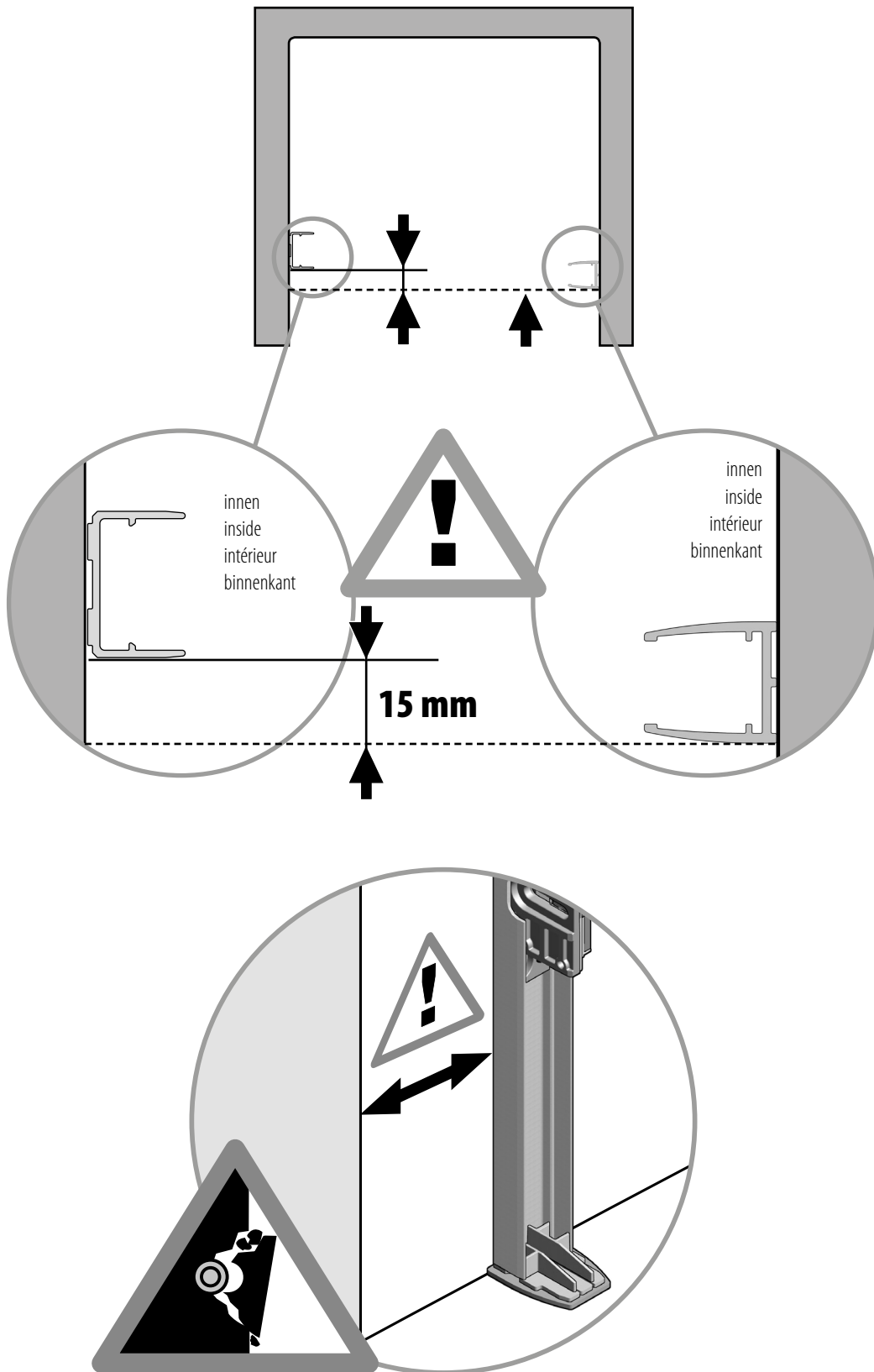

4

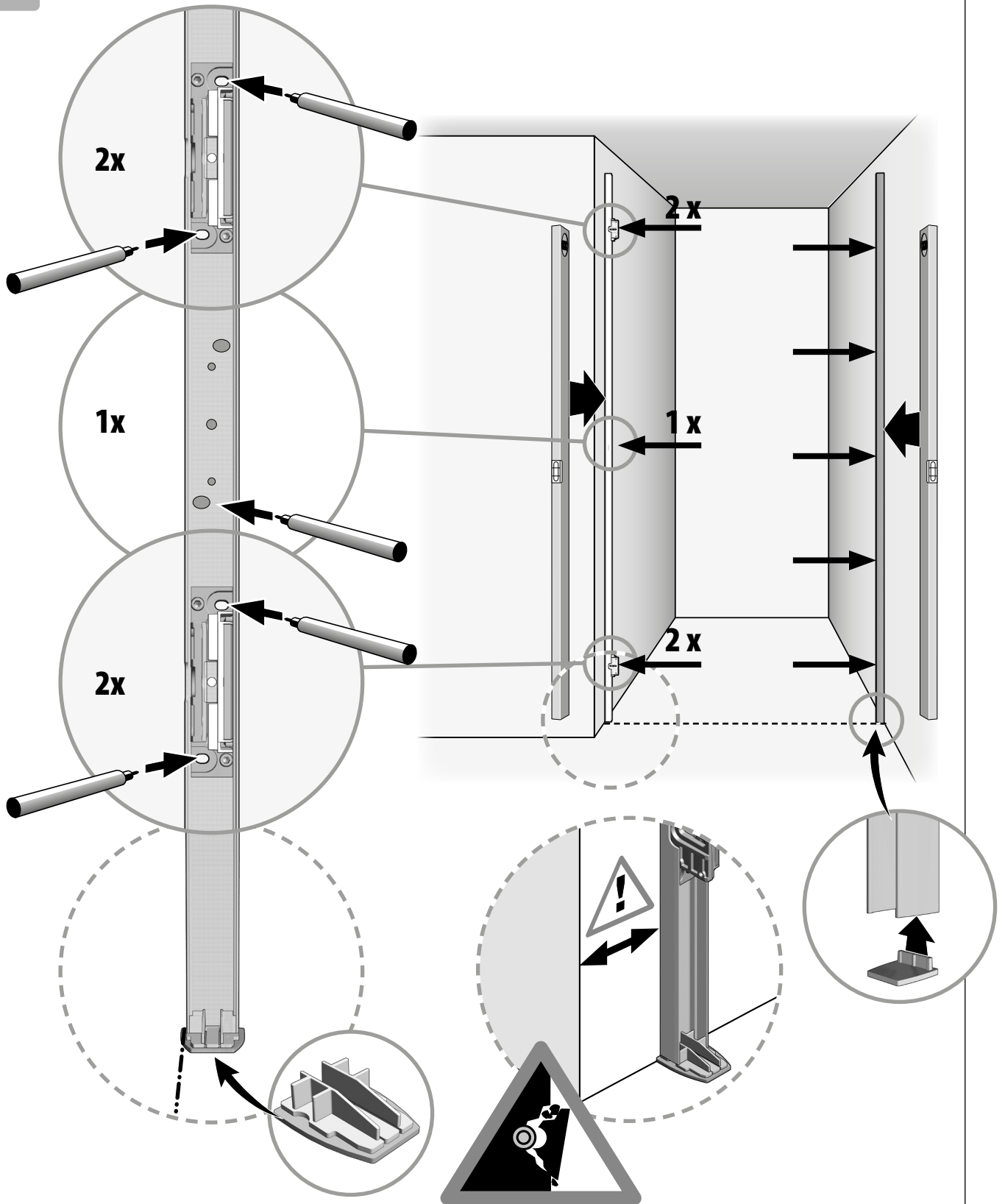

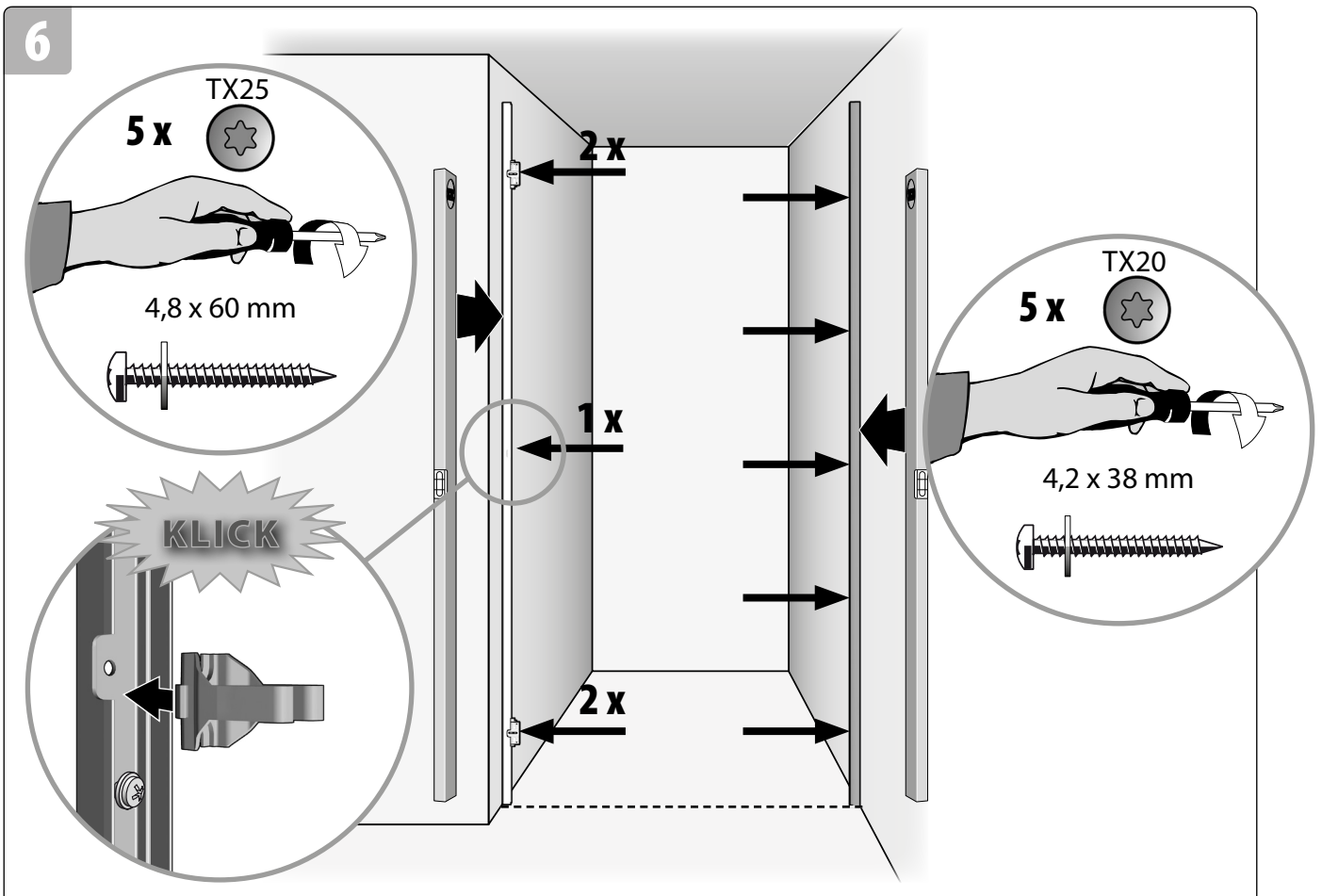
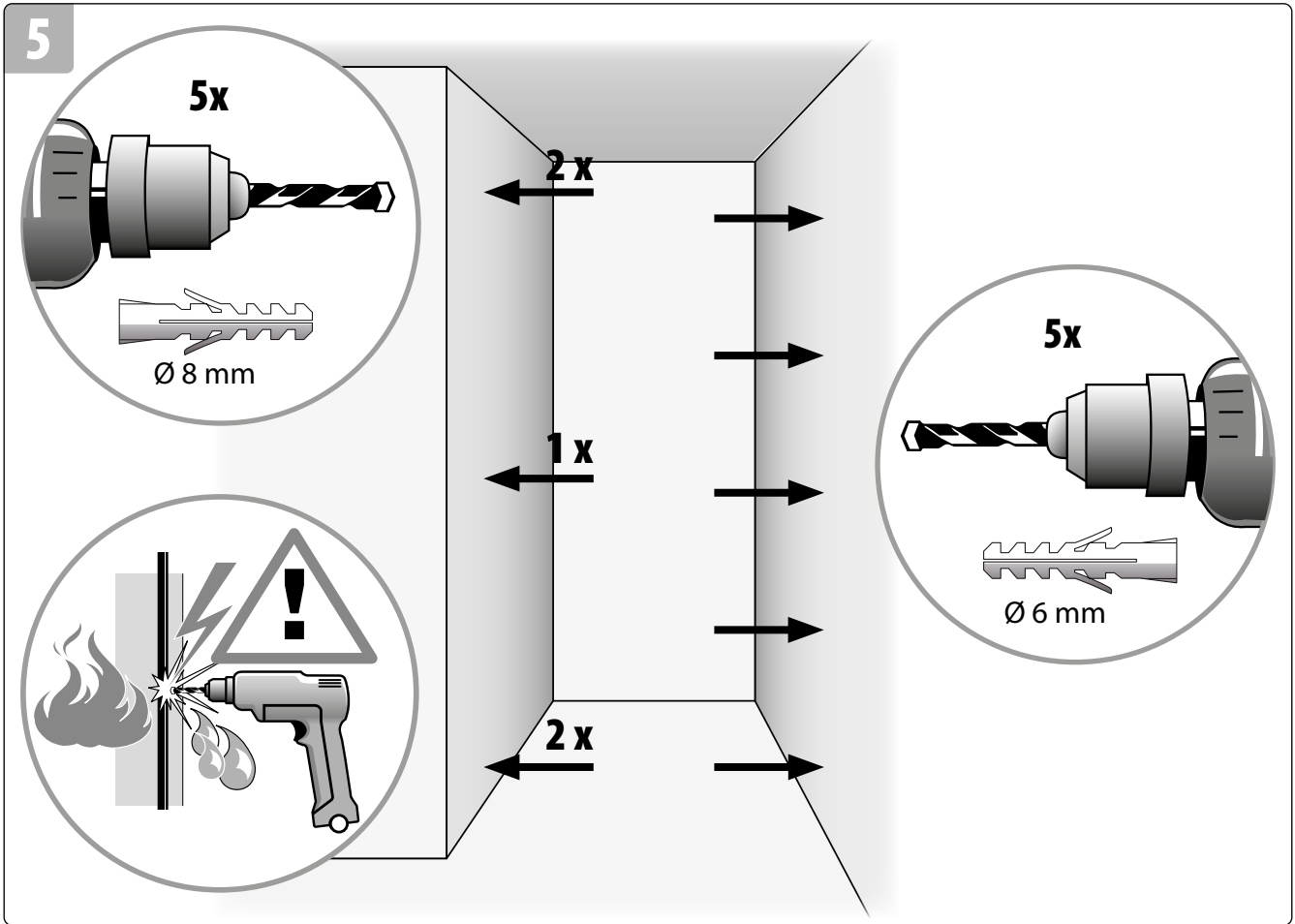

OPTIONAL	OPTIONAL	EN OPTION	OPTIONEEL
----------	----------	-----------	-----------

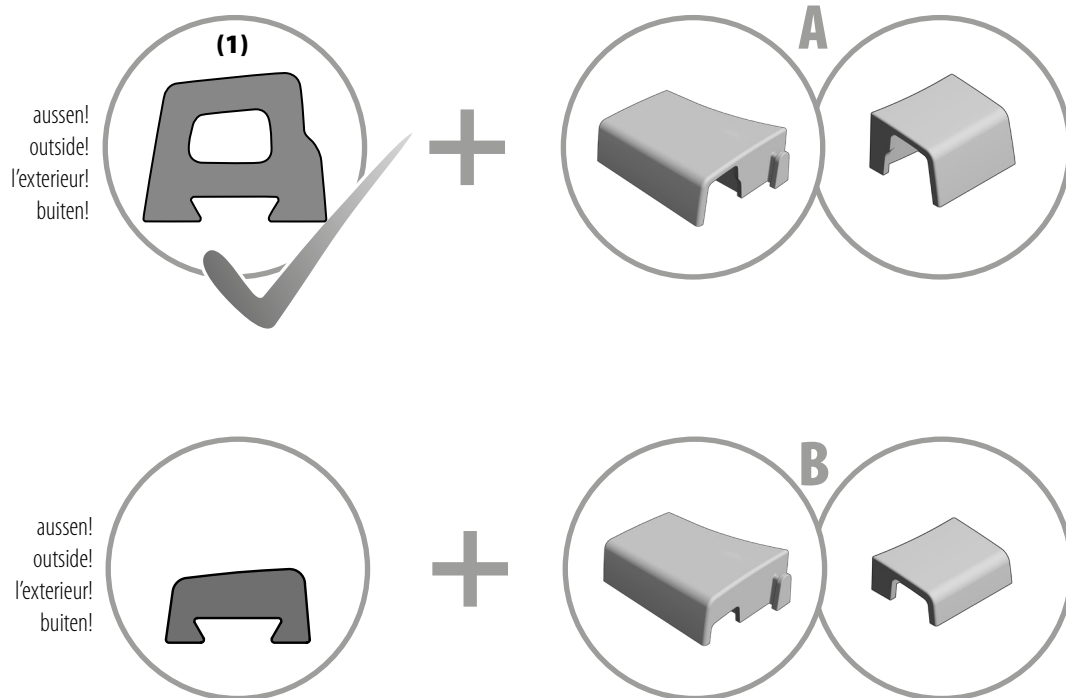

DE Der Hersteller weist an dieser Stelle ausdrücklich darauf hin, dass die Montage der im Lieferumfang enthaltenen Schwalleiste (1) zur Erreichung der Dichtungsanforderungen nach Norm (DIN 14428) erforderlich ist. Wird auf die Schwalleiste (1) verzichtet, übernimmt der Hersteller keinerlei Haftung für daraus resultierende Schäden.

Eine spätere Montage der Schwalleiste (1) ist ohne bauliche Veränderungen an der Duschtrennung möglich. Für diesen Fall bitte das nicht verwendete Montagematerial dem Endkunden zur Aufbewahrung übergeben.

EN At this stage the manufacturer makes a point of expressly informing you that mounting of the solid sealing strip (1) delivered is necessary to achieve the degree of sealing required under the standard DIN 14428.

If you dispense with the sealing strip (1), the manufacturer accepts no liability whatsoever for resulting damages.

It is possible to mount the surge strip (1) at a later date without any changes to the shower side wall. In this case please hand over the unused fixation materials to the customer for storage.

FR A cet endroit, le fabricant indique expressément que le montage de la baguette de refoulement (1) est indispensable pour obtenir l'étanchéité requise par la Norme (DIN 14428). Si toutefois cette baguette de refoulement (1) n'est pas installée, le fabricant ne peut, en aucun cas, être tenu pour responsable des dégâts qui en résulteraient.

Le montage de la baguette de refoulement (1) est toujours possible sans modification de la cabine de douche. Dans ce cas merci de remettre le matériel de montage non utilisé au client final pour le conserver.

NL De producent maakt u er op dit punt op attent, dat de montage van de in de levering opgenomen spatrand (1) nodig is om aan de dichtheidseisen naar norm DIN 14428 te voldoen. Wanneer u afziet van montage van de spatrand (1), is de producent niet aansprakelijk voor eventuele daaruit vloeiende schade.

Een latere montage van de spatrand (1) is mogelijk zonder dat een bouwkundige verandering van de doucheafdeling nodig is. In dit geval het niet het gebruikte montagemateriaal aan de eindklant geven om te bewaren.

7

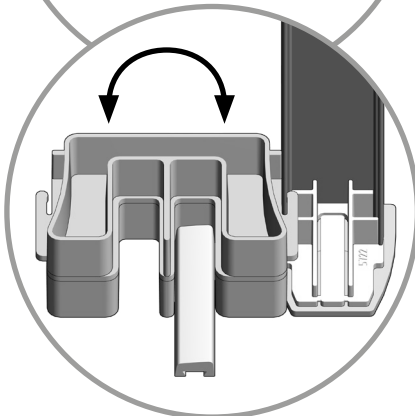
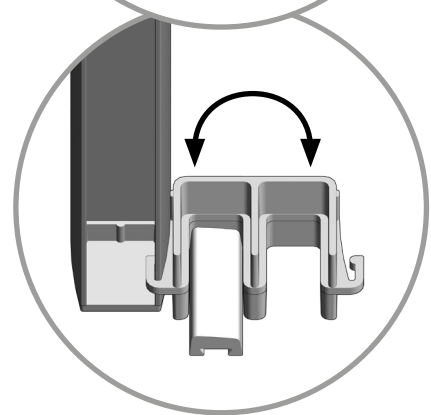
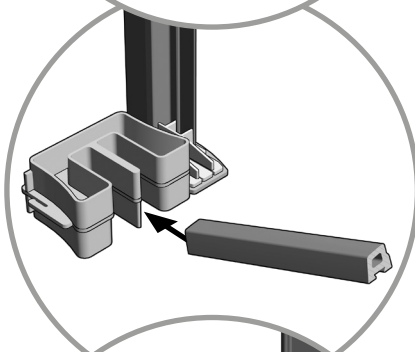
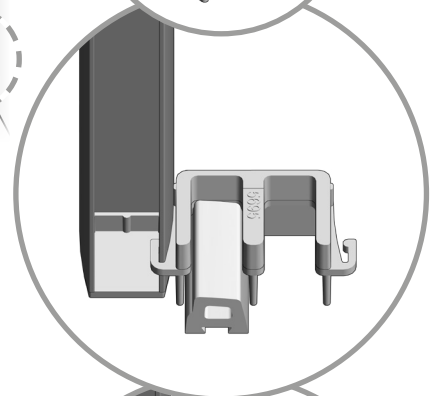
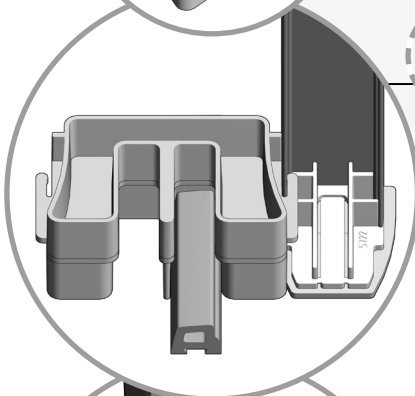
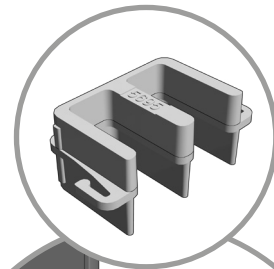
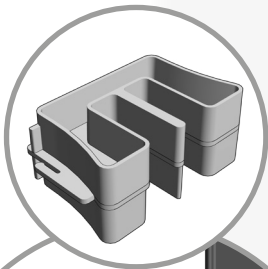

8

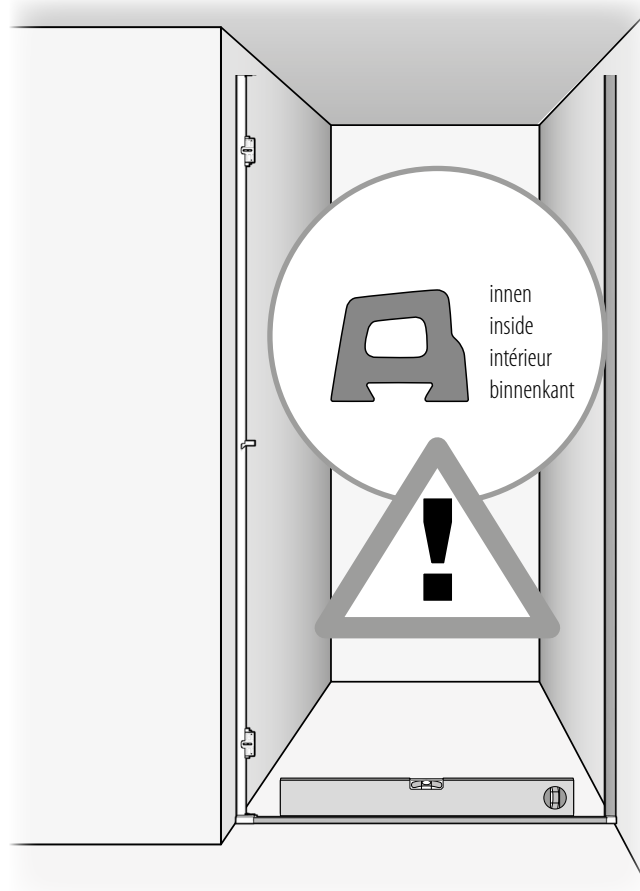

innen
inside
intérieur
binnenkant

OPTIONAL,
OPTIONAL, EN OPTION,
OPTIONEEL

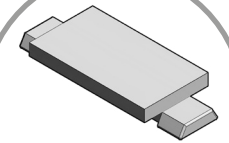
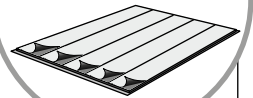

0,5mm • 1,5mm • 2,5mm

1

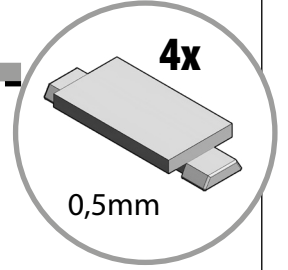
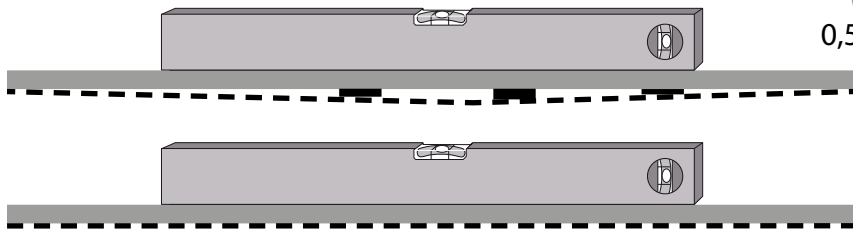

2x

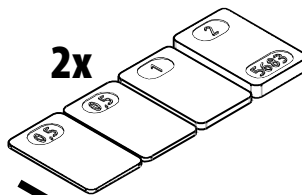

Silikon

3

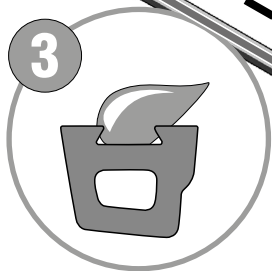

4x

2

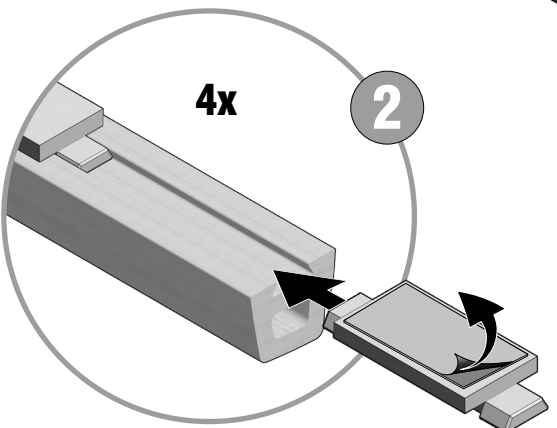

MONTAGEVARIANTEN

ASSEMBLY VARIATIONS

VARIANTES DE MONTAGE

MONTAGEVARIANTEN

DE Montage auf Duschwanne.

FR Montage sur un receveur de douche.

EN Assembly on shower tray

NL Montage op douchebak.

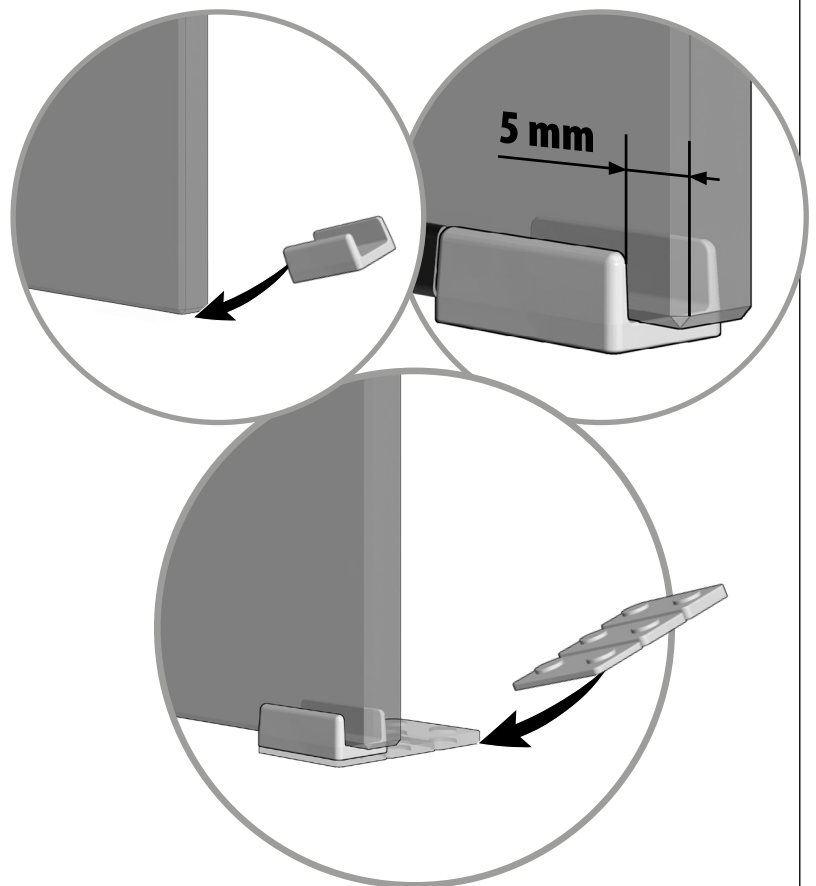
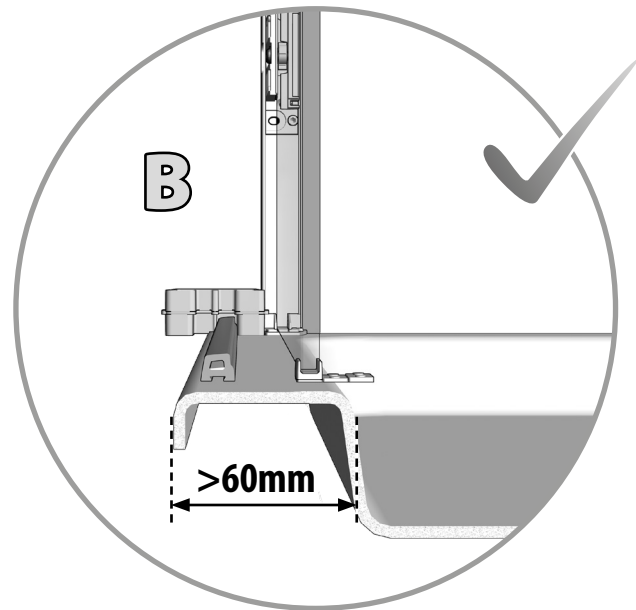
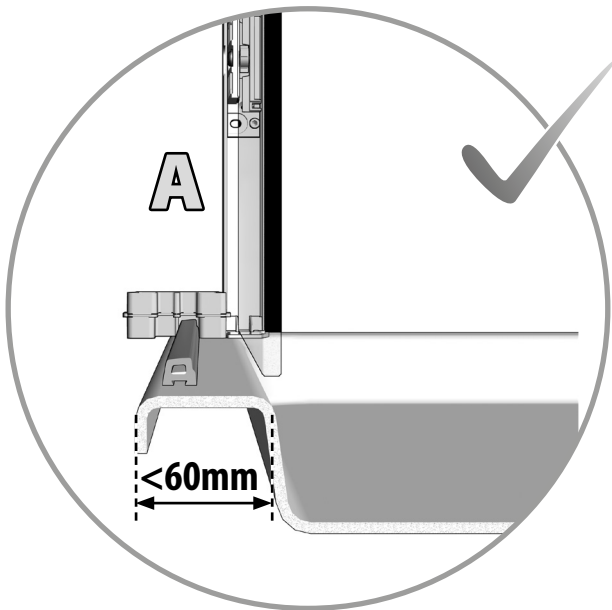

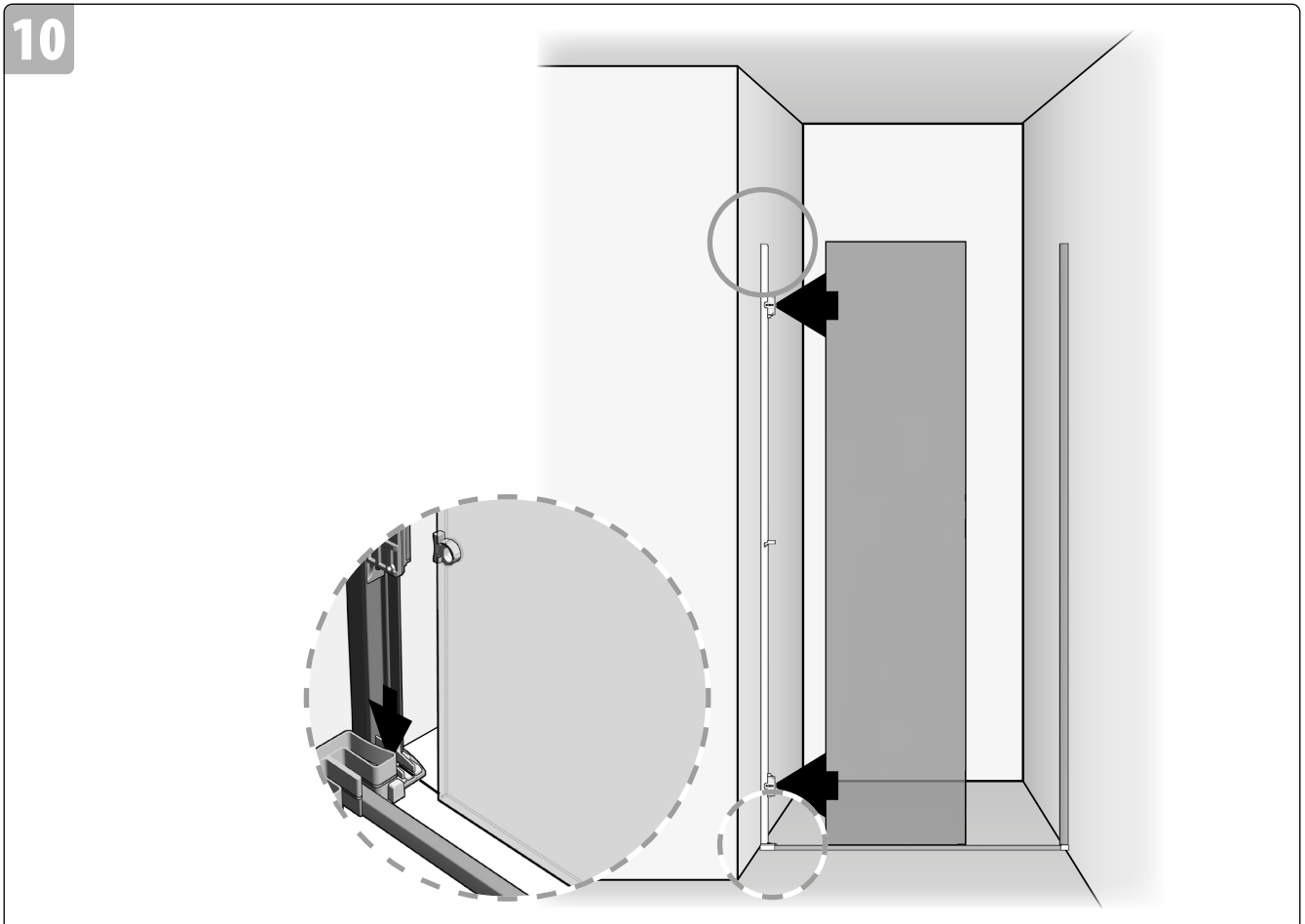
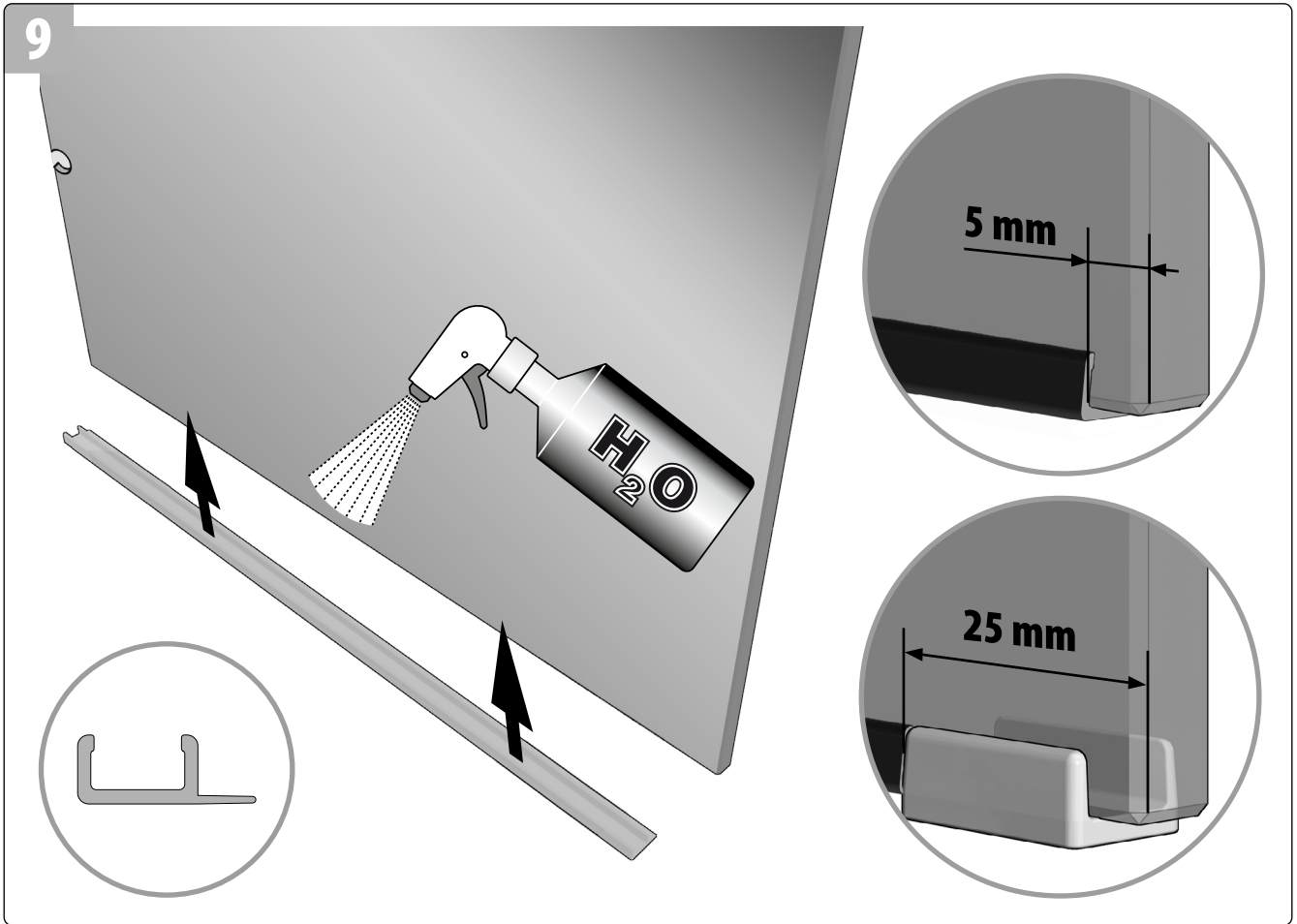

11

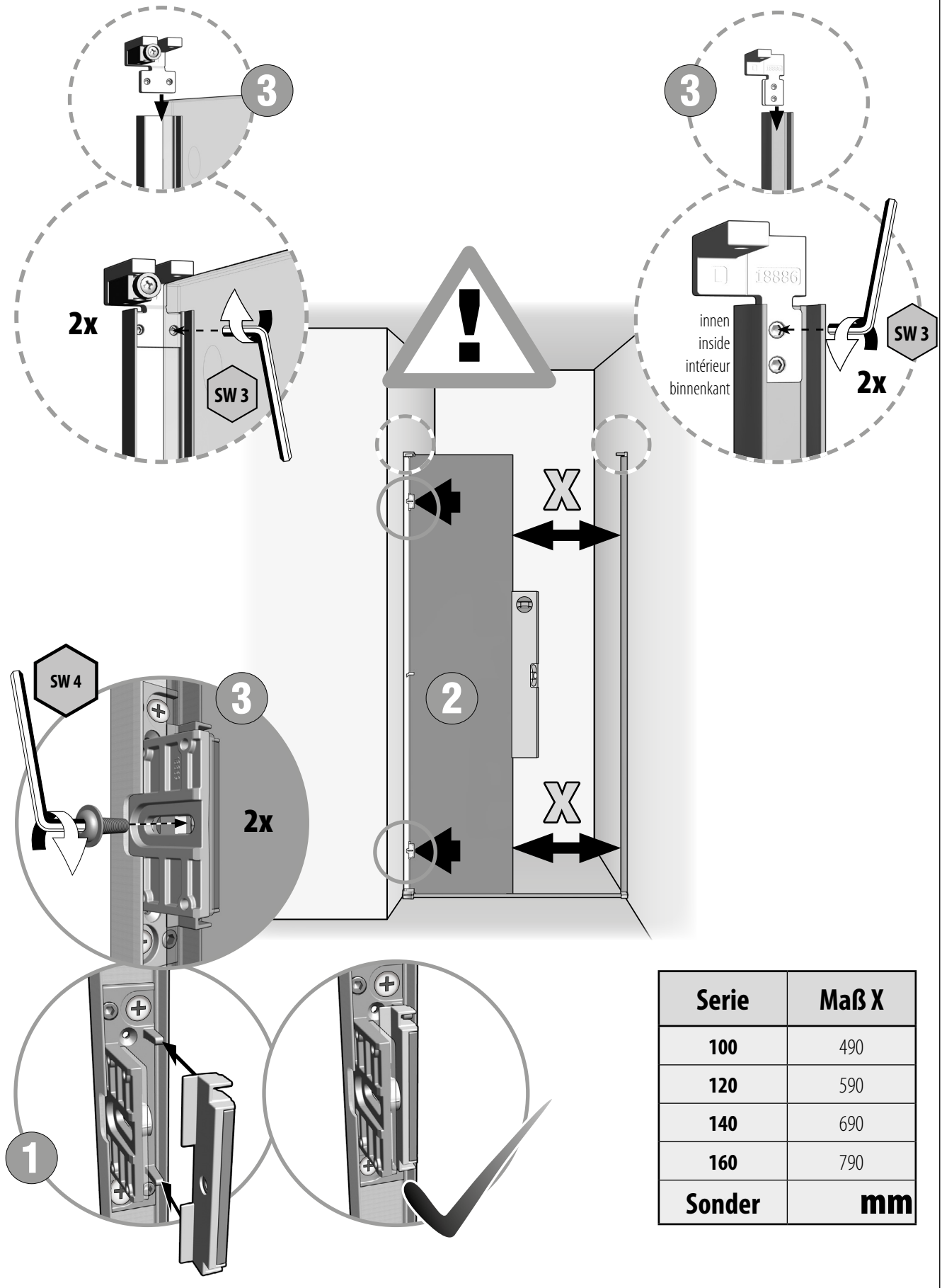

12

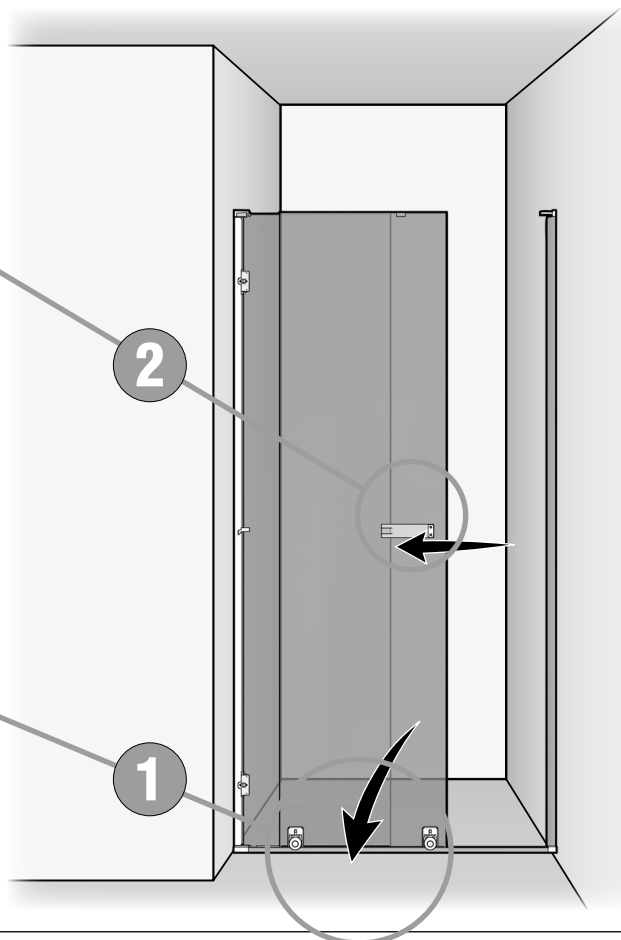
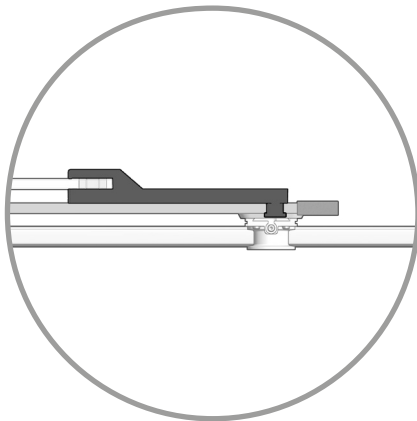
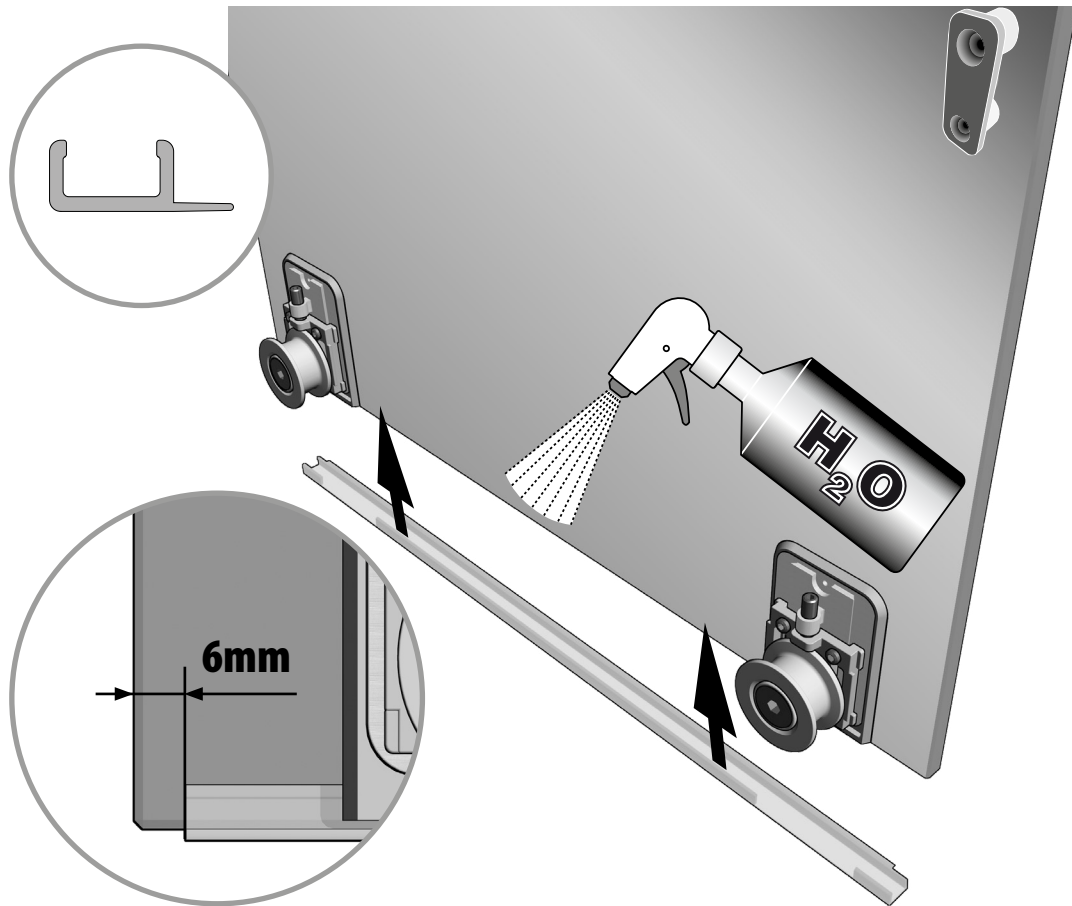

13

Ansicht von unten
View from below
Vue ci-dessous
Van onderen bekijken

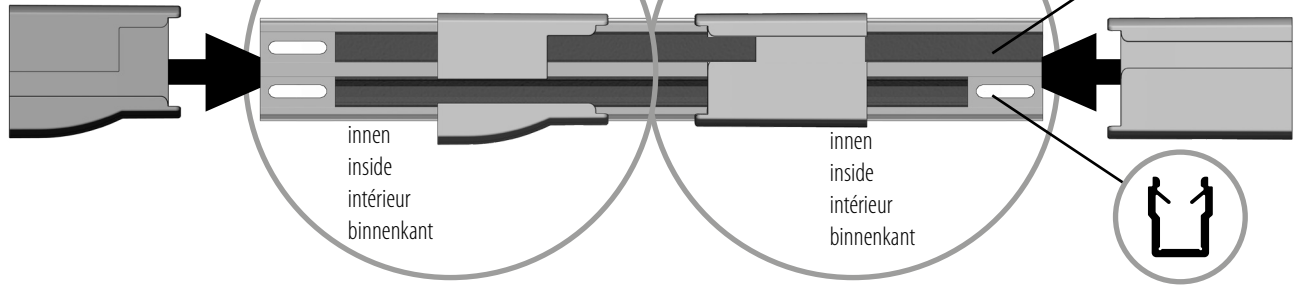

innen
inside
intérieur
binnenkant

innen
inside
intérieur
binnenkant

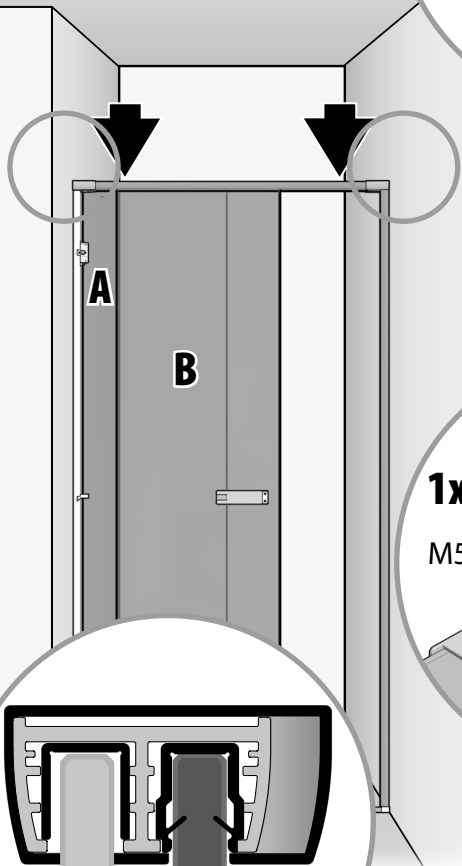
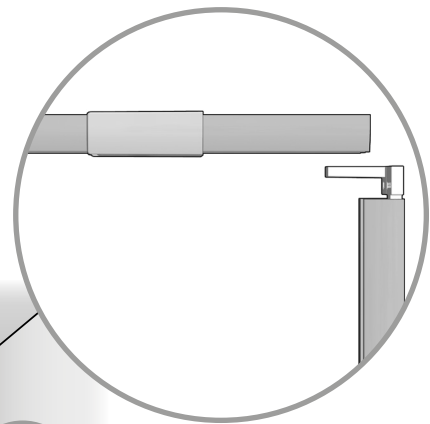
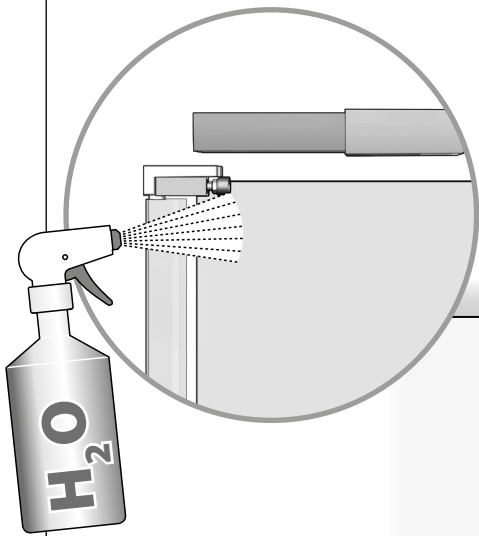

A

B

SW 3

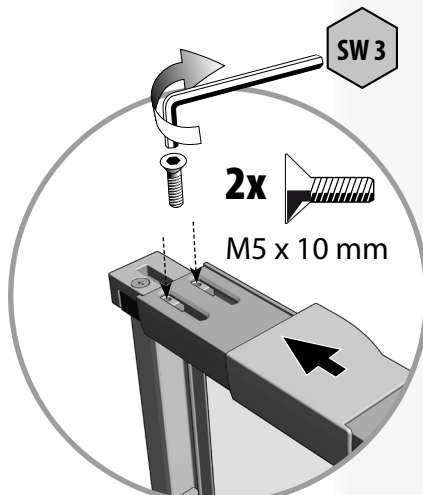

2x
M5 x 10 mm

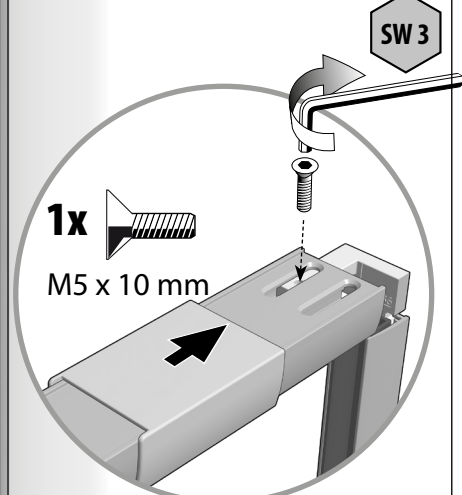

1x
M5 x 10 mm

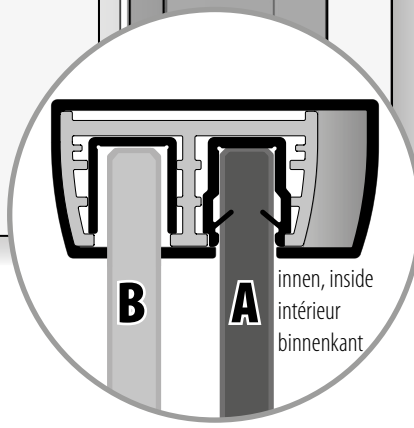

innen, inside
intérieur
binnenkant

14

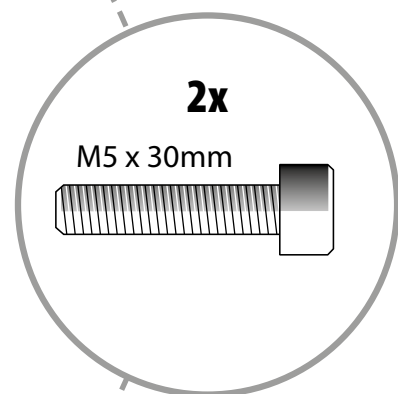
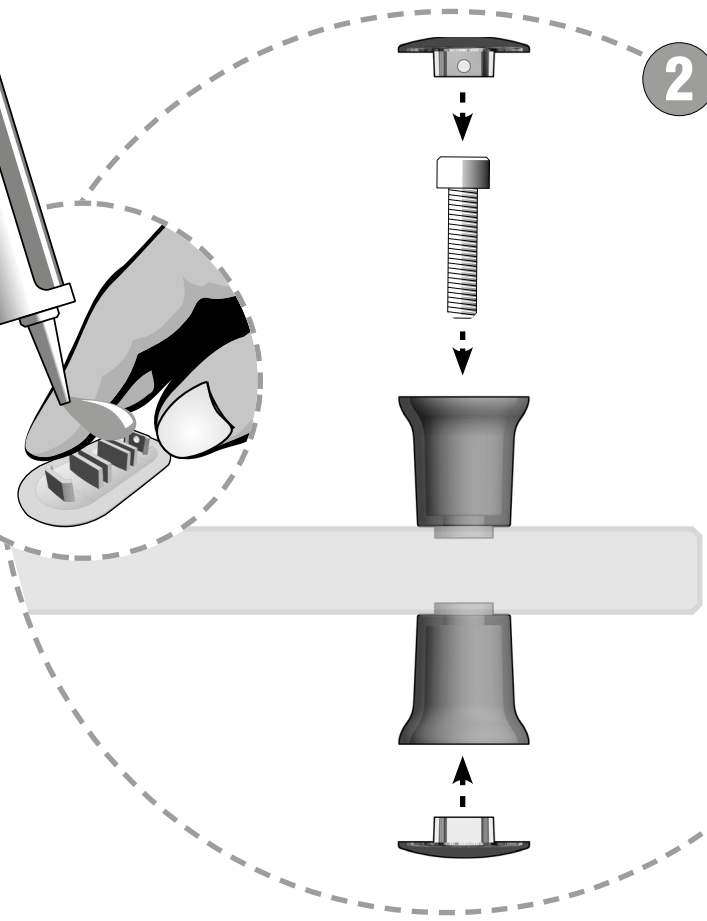
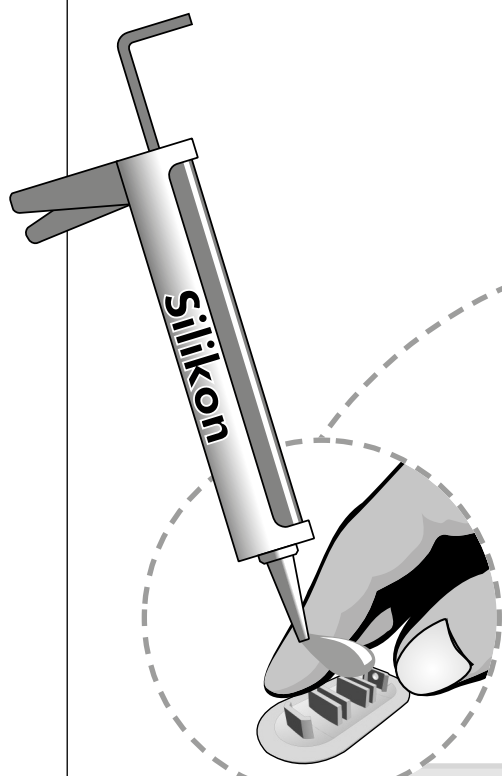
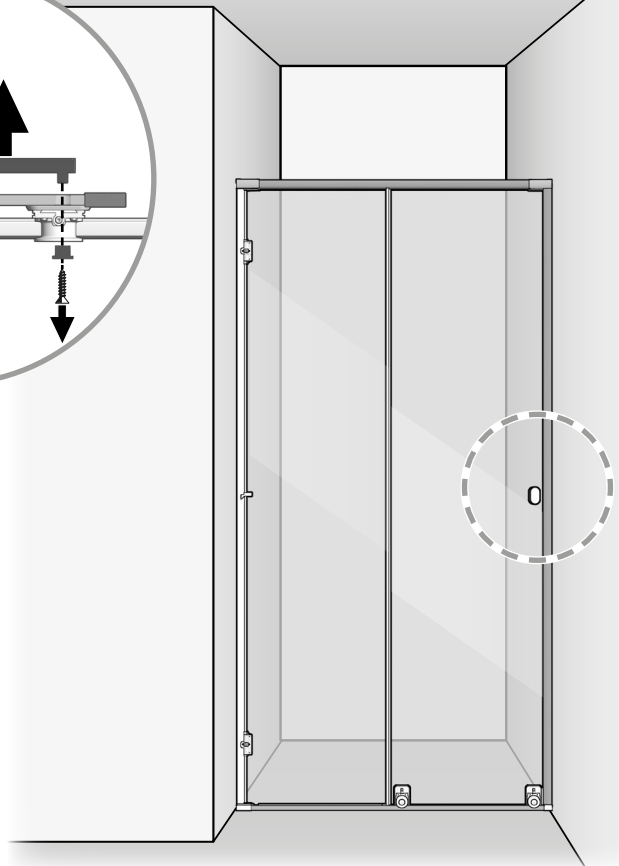
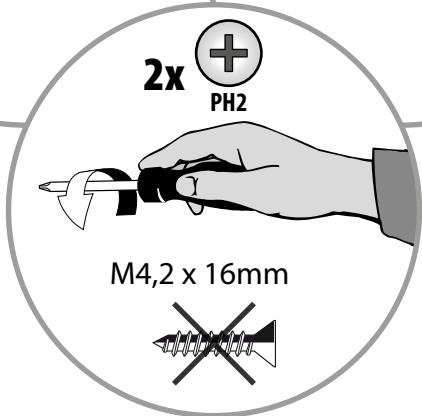
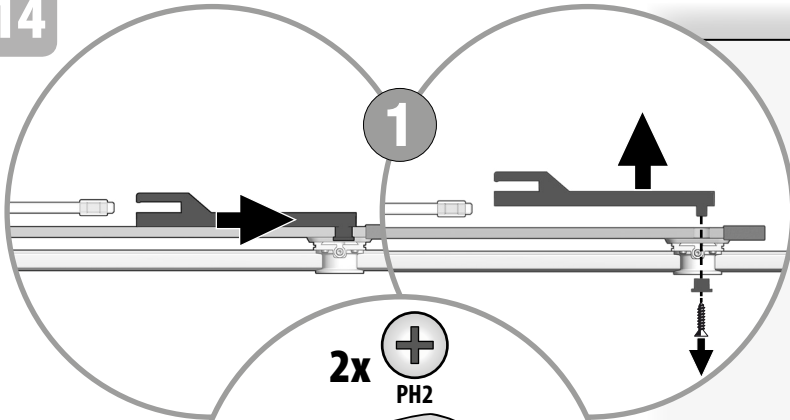

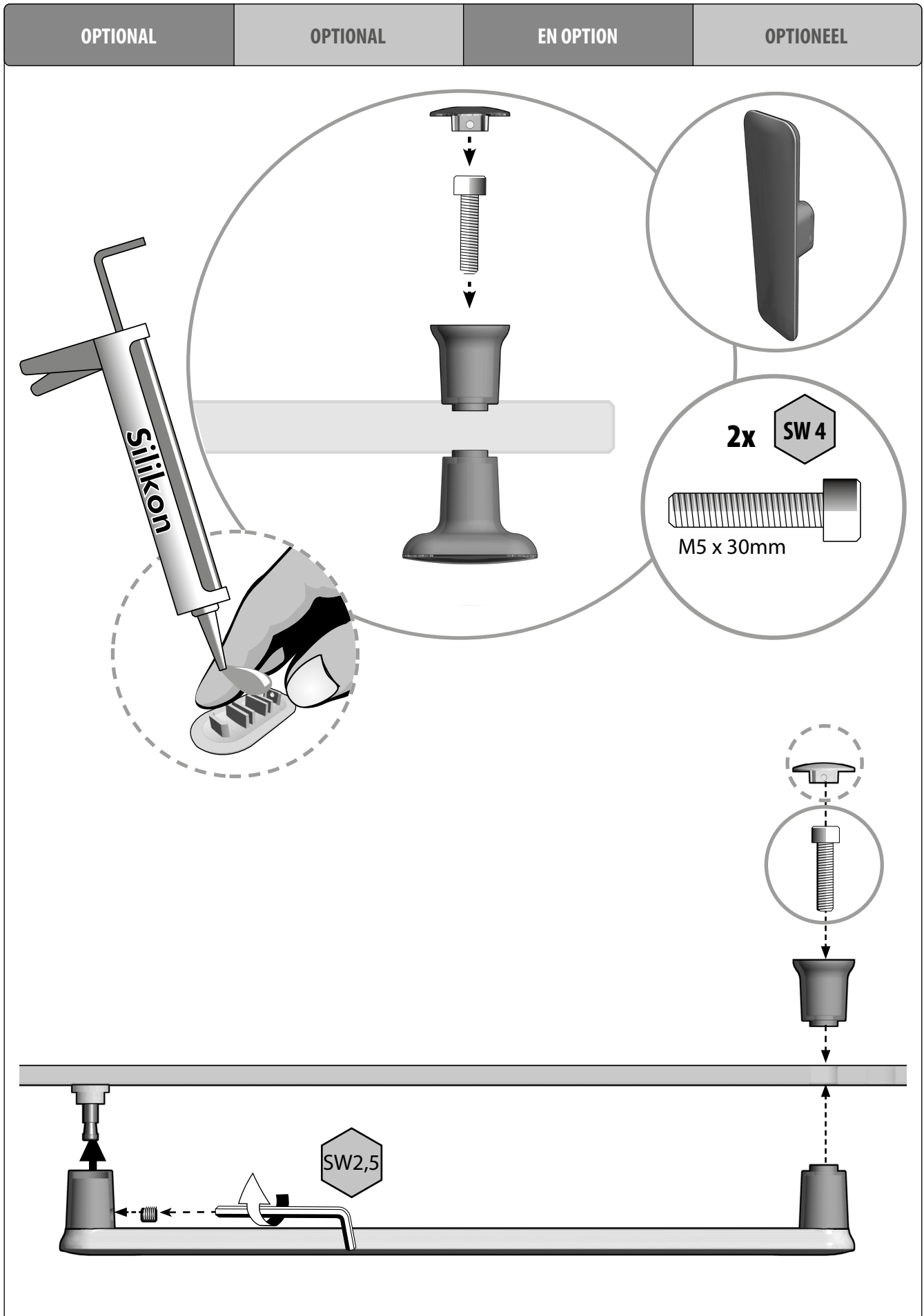

15

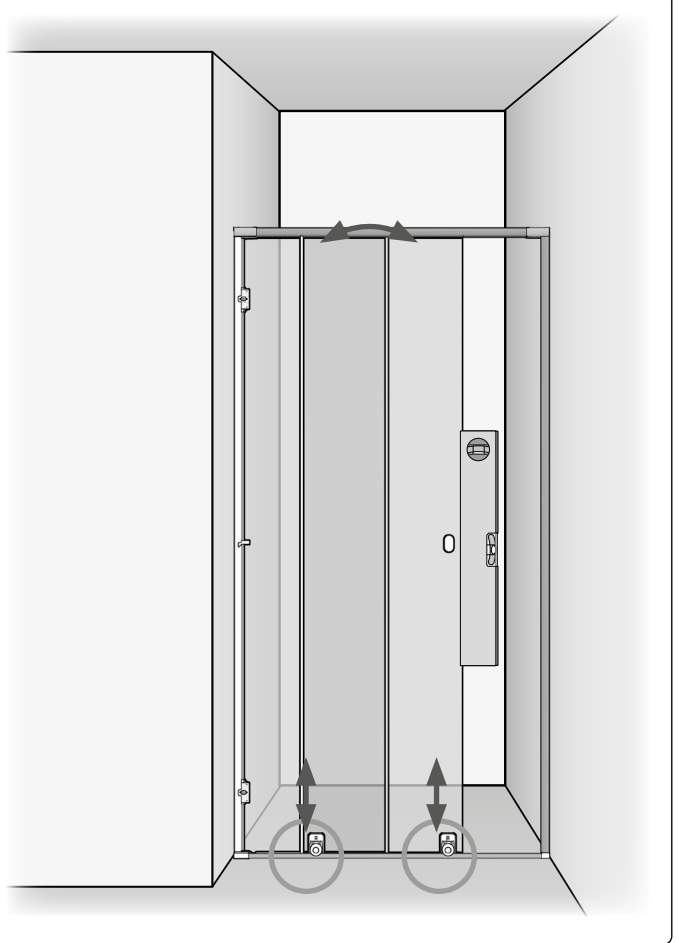
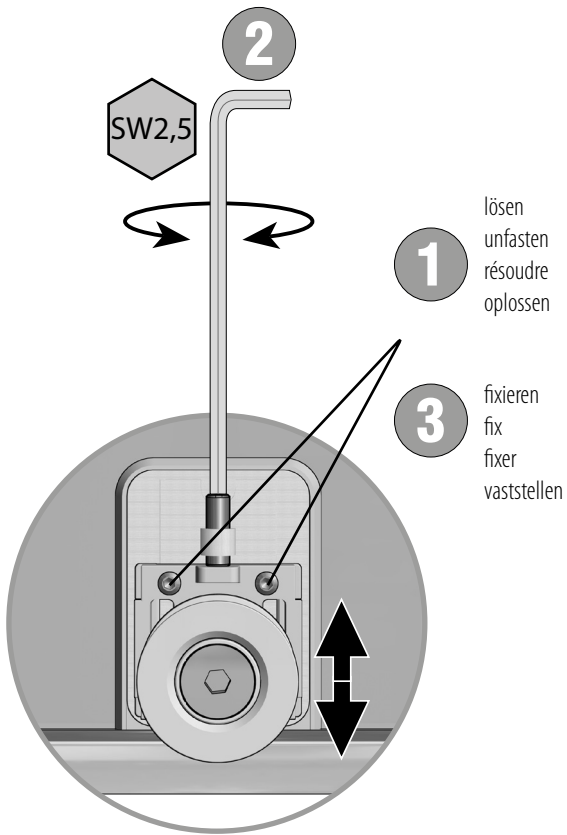

16

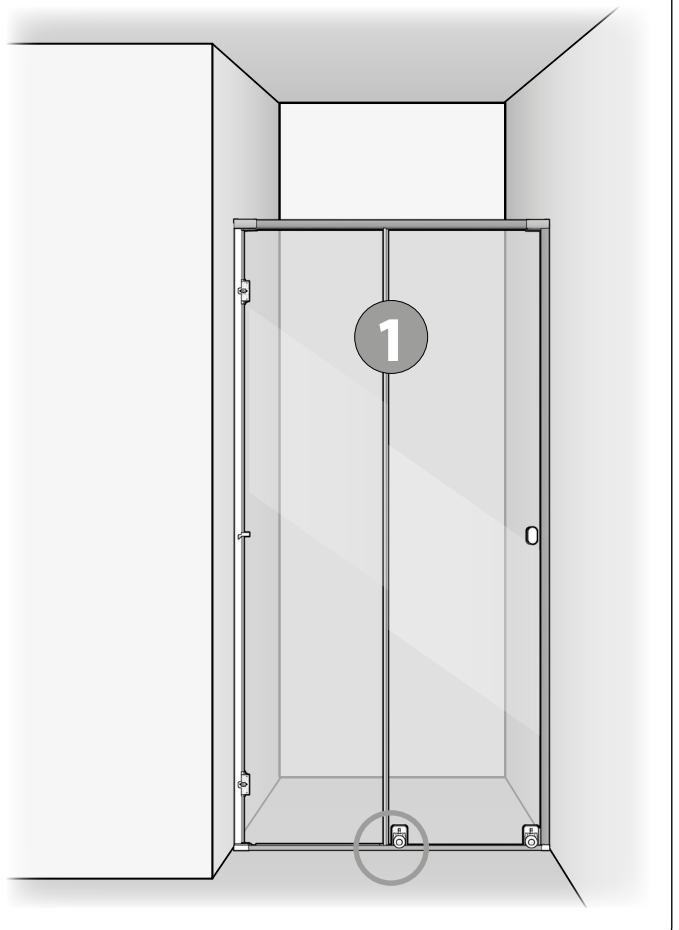
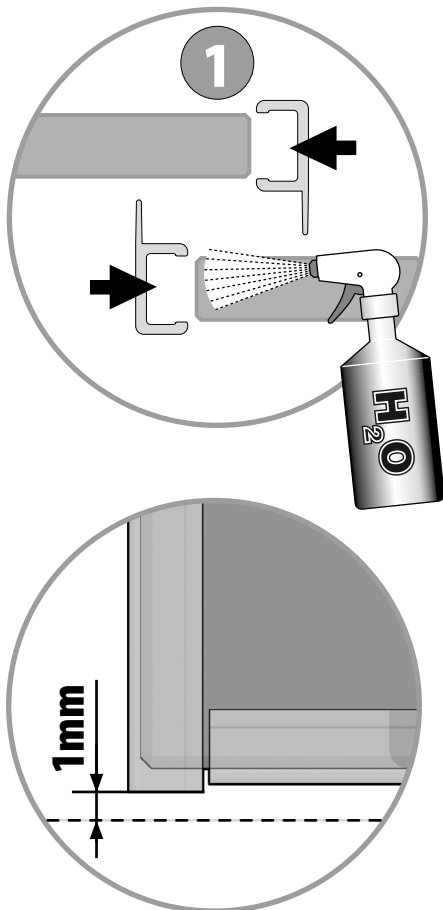

17

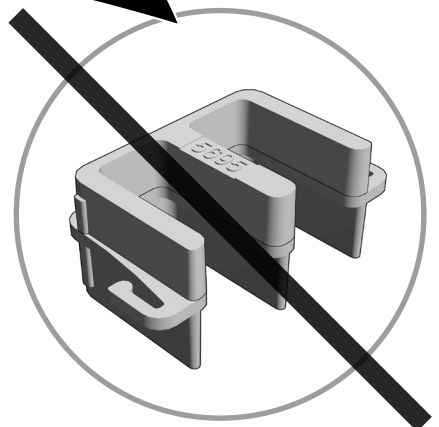
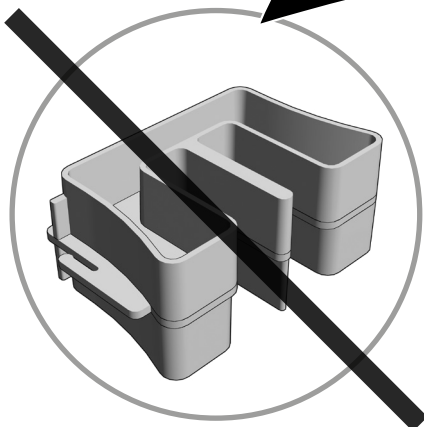
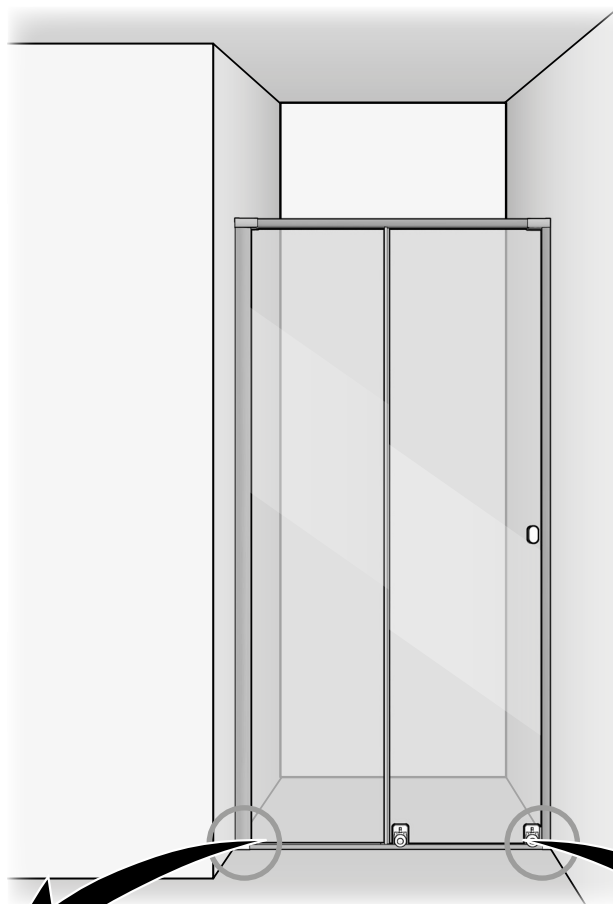

18

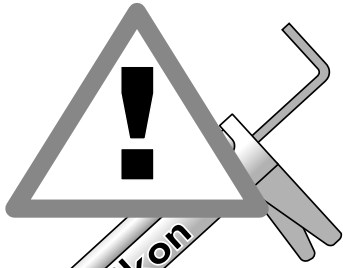

Silikon
innen
inside
intérieur
binnenkant

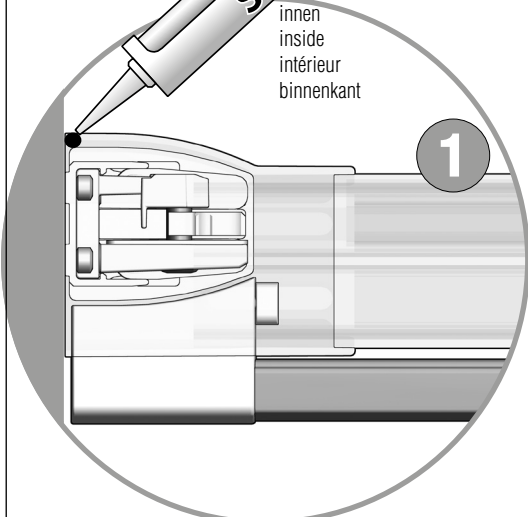

innen
inside
intérieur
binnenkant

2

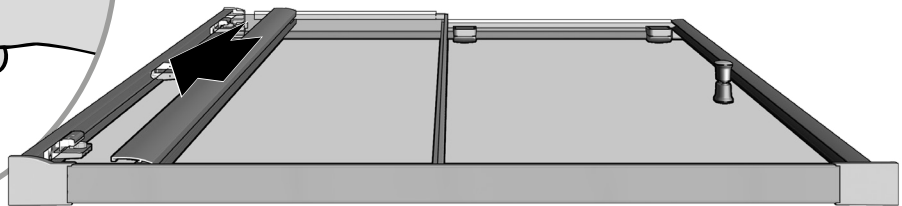
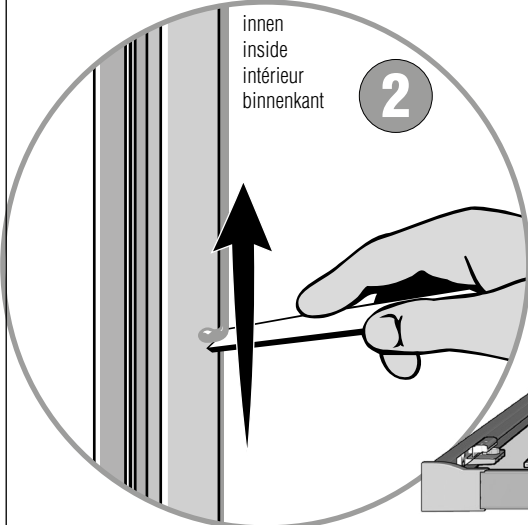

innen
inside
intérieur
binnenkant

3

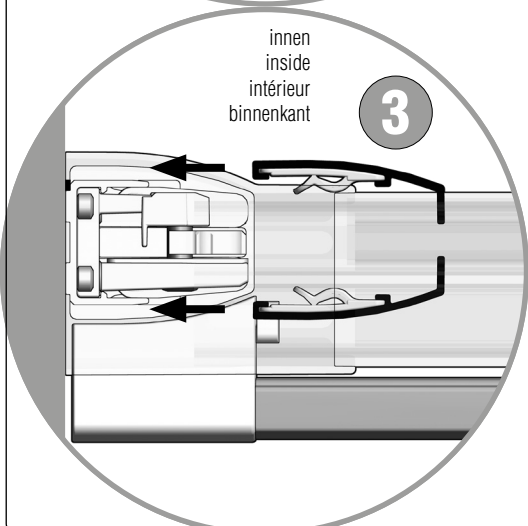

innen
inside
intérieur
binnenkant

4

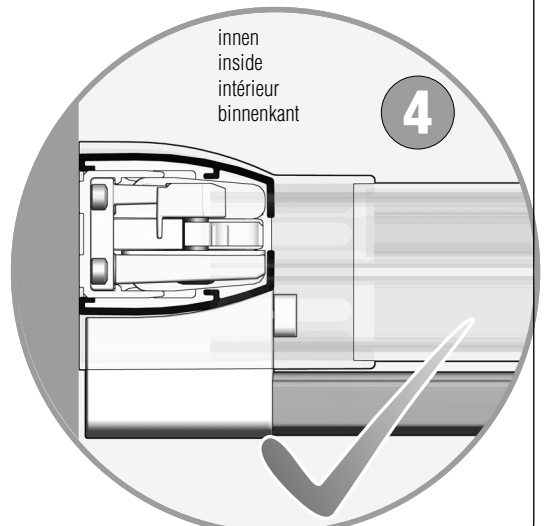

19

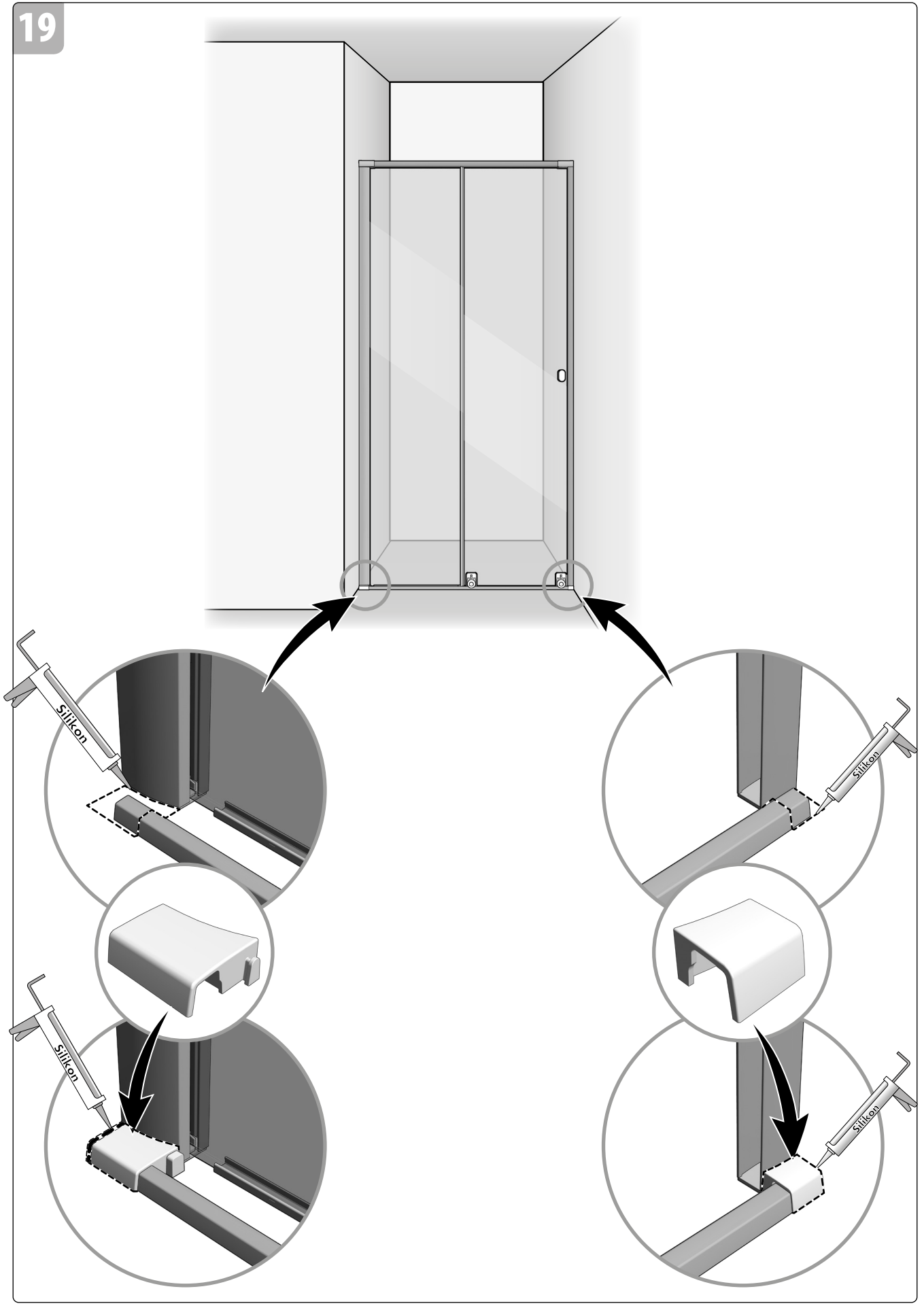

20

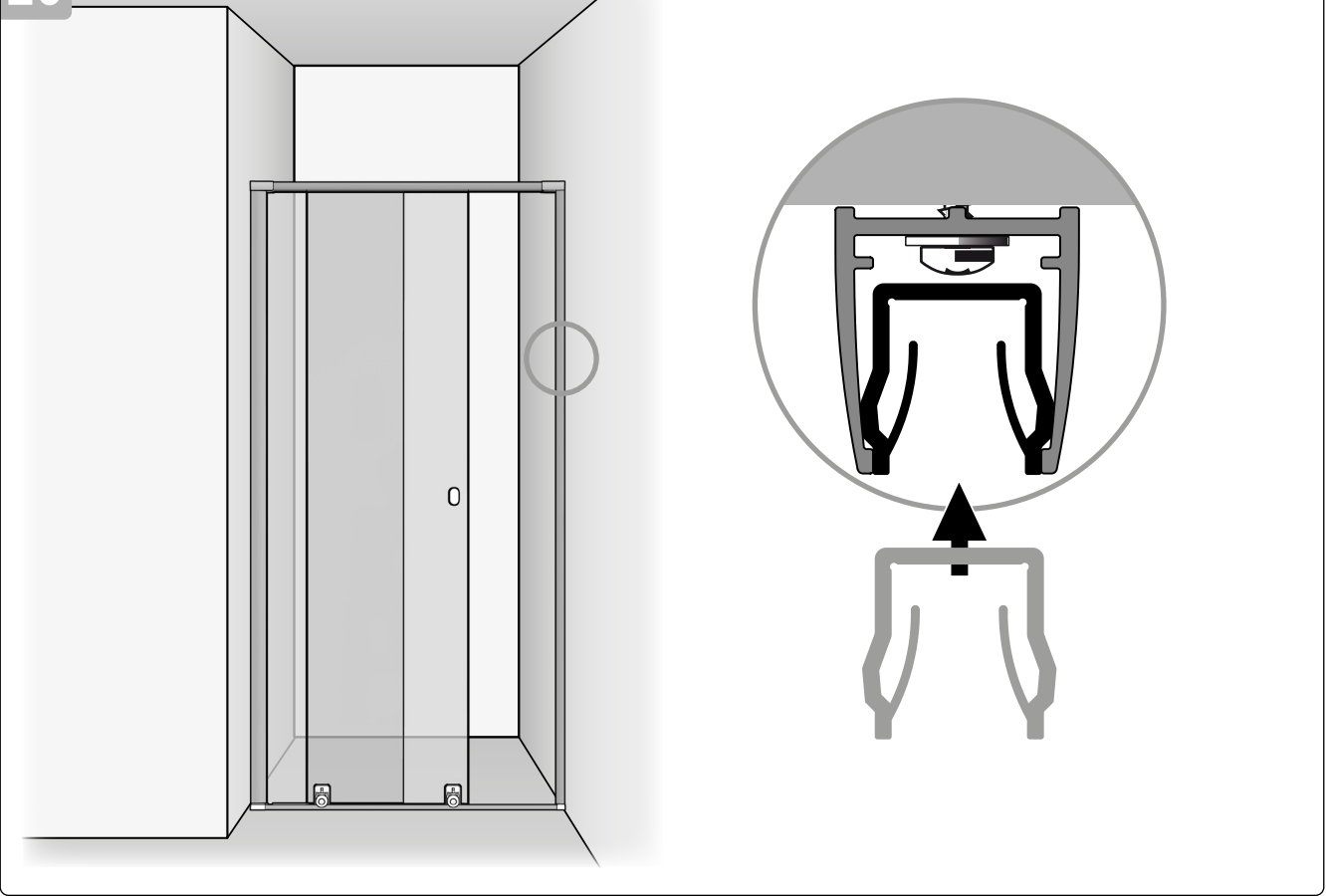

21

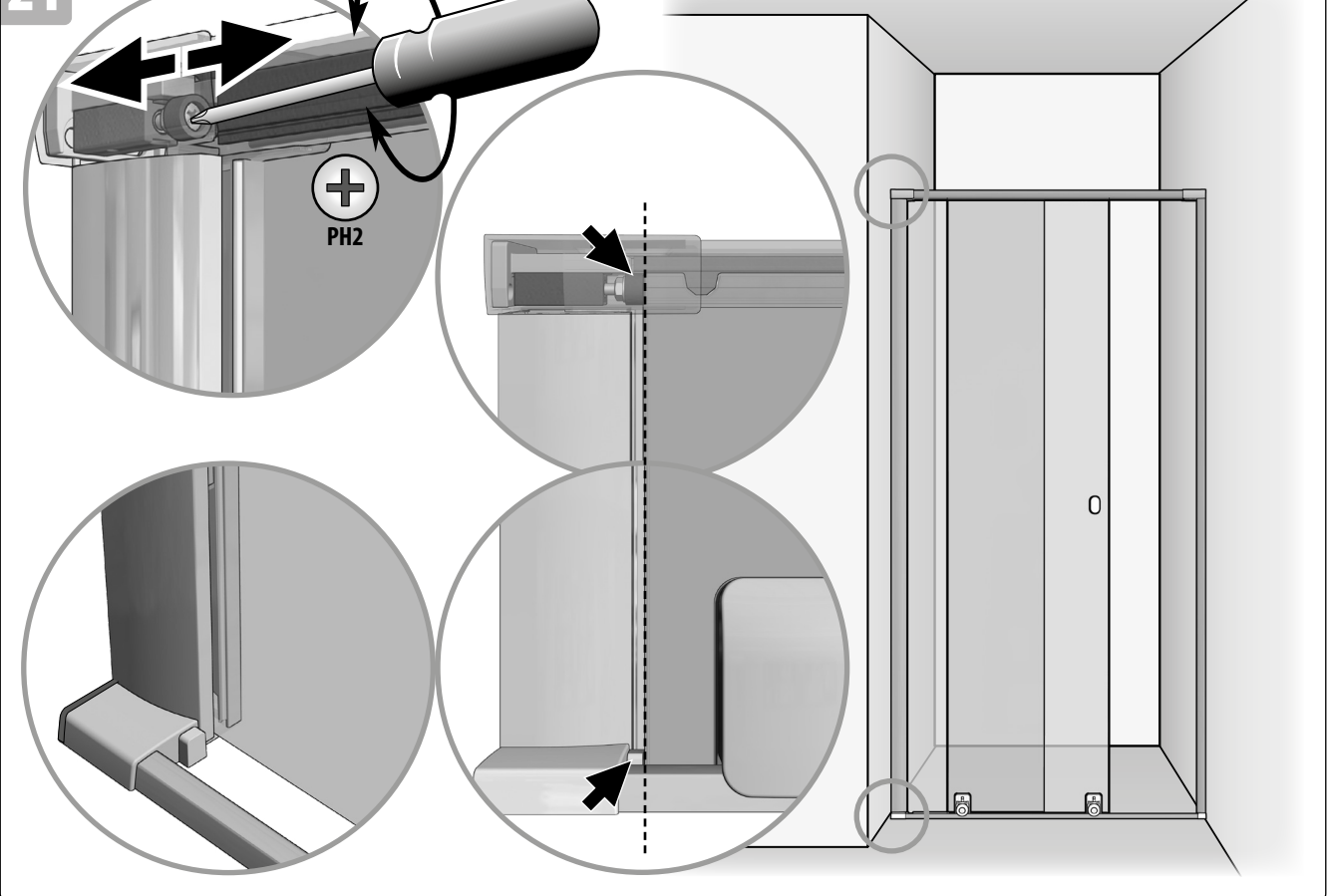

22

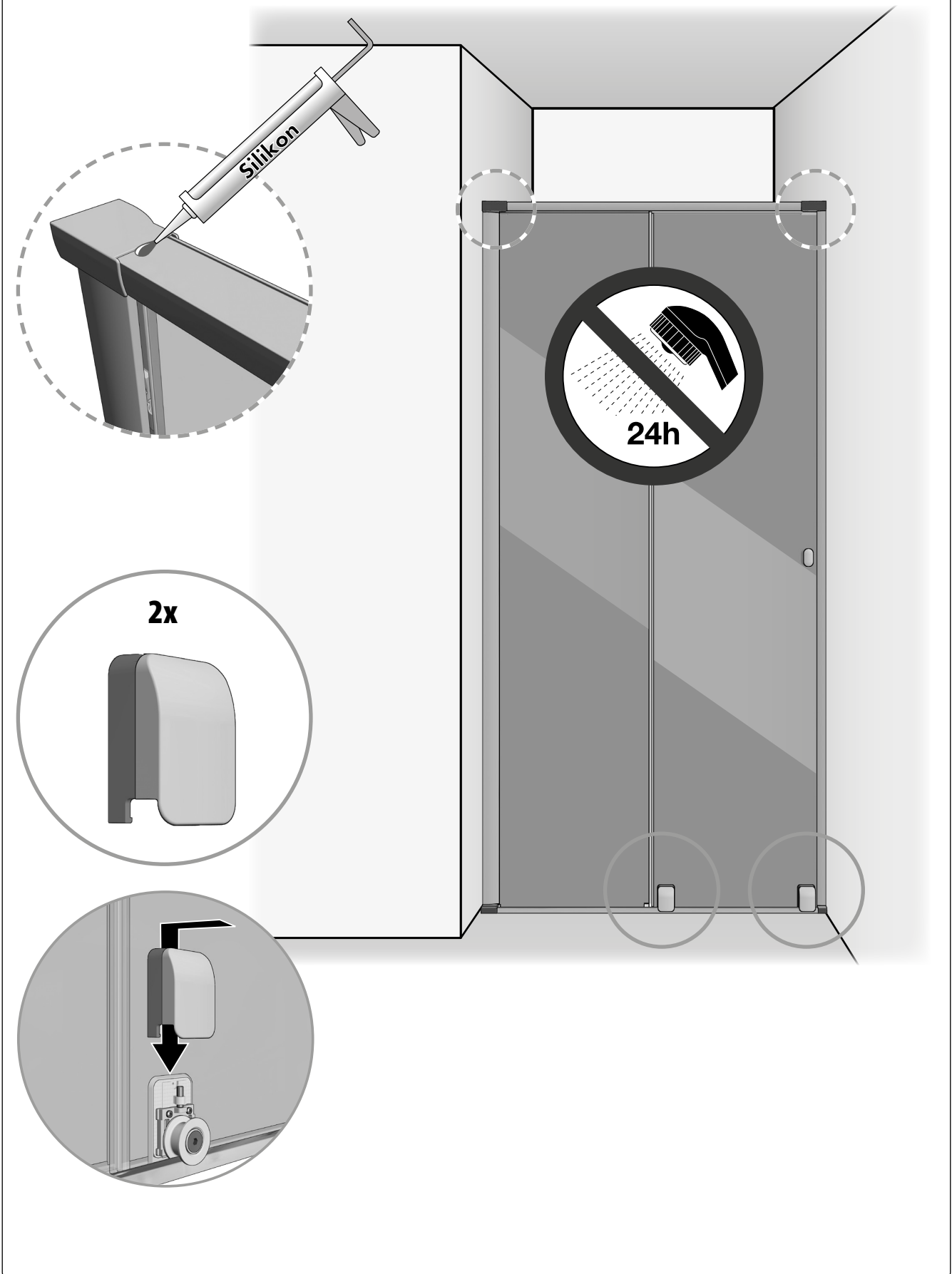

2-tlg. Schiebetür in Nische, 1 Türteil und 1 Fixteil

K 9Z317

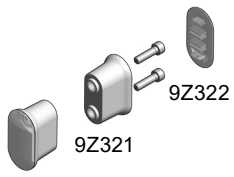

R 9Z316

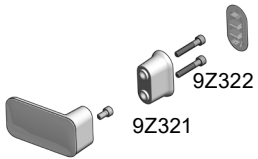

H 9Z315

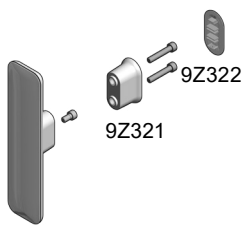

G 9Z318

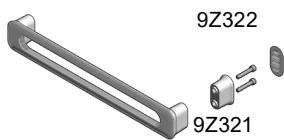

9Z804

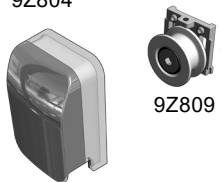

9Z711

9Z703, 9Z705, 9Z706

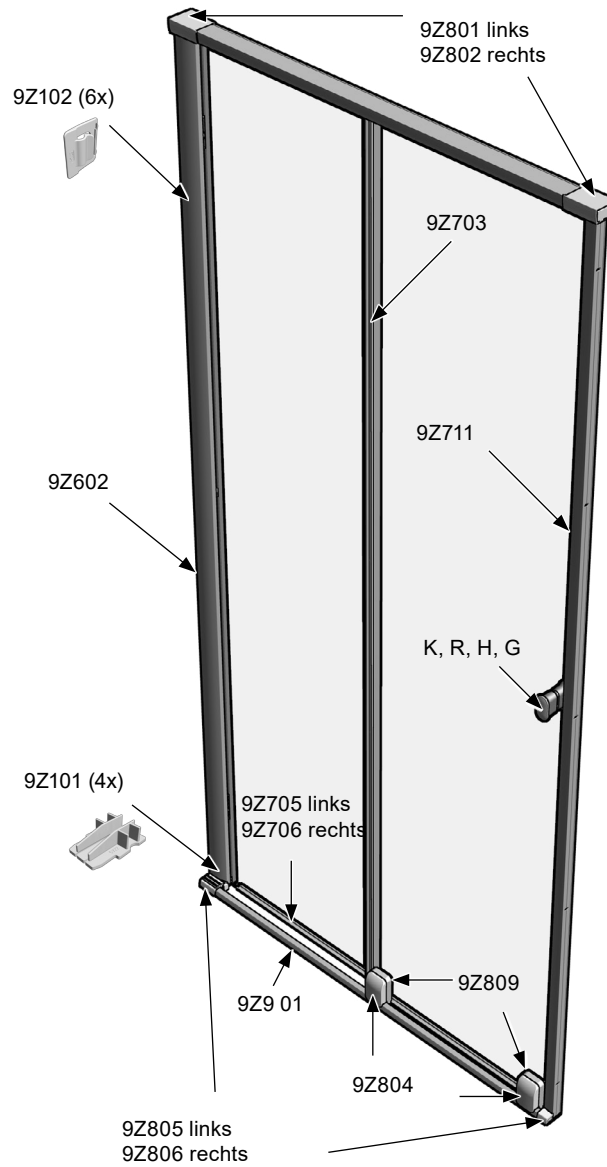

Artweger GmbH. & Co. KG
Sulzbacherstraße 60 | 4820 Bad Ischl | Austria
Tel. +43 6132 205-0 | Fax +43 6132 205-5001
info@artweger.at | www.artweger.at

Verkauf Deutschland
Artweger GmbH. & Co. KG
Postfach 1169 | 83402 Ainring | Deutschland
Tel. 0800 1114442-0 | Fax 0800 1114442-5002
info@artweger.de | www.artweger.de

Verkauf Schweiz
Artweger GmbH. & Co. KG
Postfach 16 | CH-4202 Duggingen
Tel. + 41 61 751 90 91 | Fax + 41 61 751 63 54
info@artweger.com | www.artweger.com



Druck- und Satzfehler sowie technische Änderungen vorbehalten.
Typographical errors and technical changes reserved.
Sous réserve d'erreurs d'impression ou de syntaxe ainsi que de modifications techniques.
Drukfouten, maatwijzingen en technische veranderingen voorbehouden.
Ci riserviamo errori di stampa e variazioni tecniche.