

MONTAGEANLEITUNG

WALK IN ohne Seitenwand, Anhaltestange (Ausgleich von Wandschrägen)

ASSEMBLY INSTRUCTIONS

WALK IN without side screen, grab Poles (compensation of sloping wall)

NOTICE DE MONTAGE

WALK IN sans paroi fixe, Poignées de relevage (pour rattrapage de défauts d'aplomb au mur)

MONTAGEVOORSCHRIFT

WALK IN zonder zijwand, Vasthoudstangen (voor de vereffening van schuine kanten van de muur)

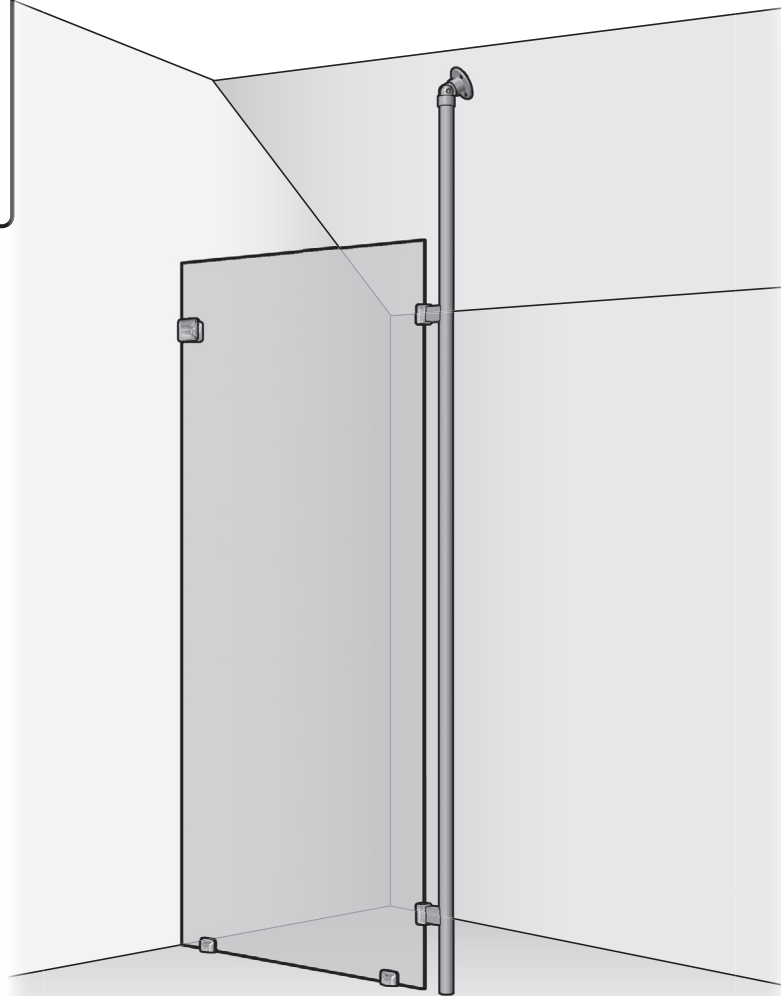

Vor Gebrauch sorgfältig lesen! Zum Nachschlagen und Aufbewahren dem Endkunden überge-

Read carefully before use! Hand over to the customer for looking up and storage!

Avant emploi lire soigneusement! Remettez le au client pour la recherche et le stockage!

Voordien gebruik zorgvuldig lezend! Overhandig de klant voor het kijken omhooggaand en opslag!

DEUTSCH
Originalsprache

ENGLISH
Translation

FRANCAIS
Traduction

NEDERLANDS
Vertaling

INHALTSVERZEICHNIS	OVERVIEW
INHALTSVERZEICHNIS2	OVERVIEW2
SICHERHEITS-HINWEISE.....4	SAFETY INSTRUKTIONEN4
INFORMATION6	INFORMATION6
BENÖTIGTES WERKZEUG6	NECESSARY TOOLS6
MONTAGESET7	ASSEMBLY KIT7
MONTAGEVARIANTEN8	ASSEMBLY VARIATIONS8
MONTAGEVARIANTEN9	ASSEMBLY VARIATIONS9
MONTAGE FIXTEIL..... 11 » JUSTIEREN 13	INSTALLATION OF IMMOVABLE ELEMENT..... 11 » ADJUST 13
MONTAGEVARIANTEN 16	ASSEMBLY VARIATIONS 16
MONTAGEVARIANTEN 17	ASSEMBLY VARIATIONS 17
MONTAGE Anhaltestange22	ASSEMBLY grab pole22
ERSATZTEILE25	SPARE PARTS.....25
<p>Montageanleitung für Einbau LINKS - bei Einbau RECHTS - spiegelgleicher Aufbau.</p>	<p>Assembly instructions for installation LEFT - for installation RIGHT - assemble in mirror image.</p>

VUE D'ENSEMBLE	OVERZICHT
VUE D'ENSEMBLE3	OVERZICHT3
INSTRUCTIONS SÉCURIT4	VEILIGHEIDS VOORSCHRIFTEN4
INFORMATION6	INFORMATION6
OUTILLAGE NECESSAIRE6	BENODIGD GEREEDSCHAP6
SET DE MONTAGE7	MONTAGESET7
VARIANTES DE MONTAGE8	MONTAGEVARIANTEN8
VARIANTES DE MONTAGE9	MONTAGEVARIANTEN9
MONTAGE PARTIE FIXE 11	MONTAGE VAST DEEL 11
» AJUSTER 13	» GOED AFSTELLEN 13
VARIANTES DE MONTAGE 16	MONTAGEVARIANTEN 16
VARIANTES DE MONTAGE 17	MONTAGEVARIANTEN 17
MONTAGE Poignée de relevage22	MONTAGE Vasthoudstange22
PIÈCES DÉTACHÉES25	ONDERDELEN25

C'est prévue pour une installation à GAUCHE –
en cas d'une installation à DROITE -A inverser pour partie fixe en GAUCHE.

Montagevoorschrift voor inbouw LINKS -
bij inbouw RECHTS - montage in spiegelbeeld.

SICHERHEITS-HINWEISE

SAFETY INSTRUCTIONS

INSTRUCTIONS SÉCURIT

VEILIGHEIDS VOORSCHRIFTEN

DE Vor dem Einbau bitte unbedingt beachten!

- Produkt **vor dem Einbau**, auf Richtigkeit, Beschädigungen und das Zubehör auf Vollständigkeit **überprüfen**.
- **Bei sichtbarem Schaden Produkt keinesfalls einbauen!**
- **Beachten Sie beim Hantieren das teilweise hohe Gewicht und/oder die großen Abmessungen von Einzelteilen.**
- **Beachten Sie beim Bohren der Löcher, dass Sie keine Leitungen (Elektro, Gas, Wasser) beschädigen.**



Unsere Haftung beschränkt sich alleine auf unsere Produkte und kann daher nicht auf den Ein- und Ausbau ausgedehnt werden. Die Kosten für einen nachträglichen Aus- und Einbau eines Produkts und die damit verursachten Schäden sind **kein** Bestandteil der Garantie.

EN Please note carefully before installing

- Before installing, check for correctness and damage and the accessories for completeness.
- **Do not under any circumstances install product with visible damage!**
- **Take the great weight and/or the large dimensions into consideration when handling individual parts!**
- **When drilling holes do not damage hidden pipes and wiring.**

Our liability is limited to our products alone and therefore cannot be extended to installation and dismantling. Costs for subsequent dismantling and installation of a product and damage caused thereby are not part of the guarantee.

FR A respecter impérativement avant le Montage

- Avant le montage de vérifier qu'il s'agit du bon modèle, qu'elle n'est pas endommagée et que les accessoires sont complets.
- **En cas de dommages visibles, ne pas monter le produit!**
- **Lors de la manutention, merci de prêter attention au poids parfois très élevé et/ou aux dimensions de certaines pièces!**
- **Faites attention en perçant les trous de ne pas endommager les tuyauteries (cables électriques, canalisations de gaz, d'eau, etc).**

Notre responsabilité se limite à nos produits et ne peut être étendue sur l'installation et le démontage. Les coûts générés lors d'un démontage après installation et d'une ré-installation d'un produit et les dommages qui en résultent ne pourront être pris en charge par la garantie.

NL Voor inbouw beslist in acht nemen!

- Bad voor het inbouwen op juistheid, beschadigingen en toebehoren op volledigheid controleren.
- **Bij zichtbare beschadiging product in geen geval inbouwen!**
- **Let u bij het gebruik om het gedeeltelijk grote gewicht en/of de grote afmetingen van enkele onderdelen!**
- **bij het boren van gaten er op letten, dat U geen leidingen (elektro, gas of water) beschadigt!**

Wanneer het bad betegeld wordt, beslist de inbouwmaten van de badkuip en van de doucheafscheiding in acht nemen. Onze aansprakelijkheid is beperkt tot onze producten en kan daarom niet op de in- en uitbouw uitgebreid worden. De kosten voor een latere uit- en inbouw van een product en de daaruit voortvloeiende schade zijn geen onderdeel van de garantie.

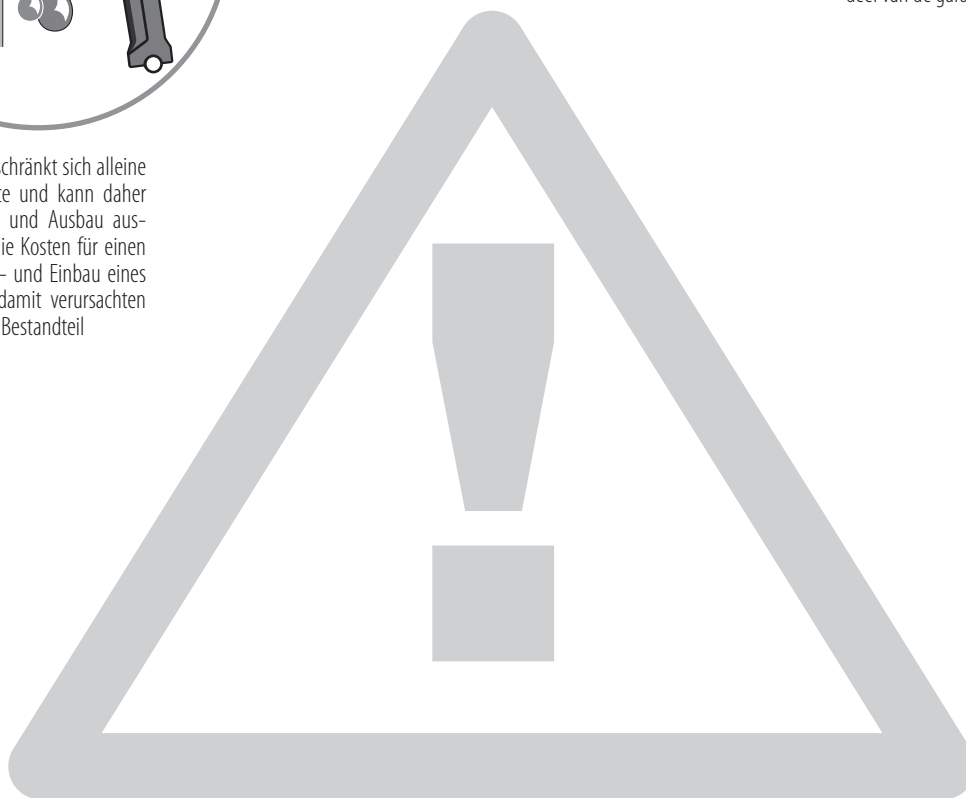



DE ACHTUNG!
Beim Hantieren
mit Glas Schutz-
kleidung tragen!

Bitte untersuchen Sie nach dem Auspacken das Einscheiben-Sicherheitsglas (ESG) unverzüglich auf mögliche Transportschäden, wie abgesprungene Kanten oder Ecken. Wird ein Schaden festgestellt bitte umgehend Schadensmeldung machen und die Scheibe nicht einbauen, da dieser Fehler auch später zu einem Bruch führen kann! Alle Gläser werden vor dem Verpacken sorgfältig kontrolliert. Spätere Reklamationen, auch bei Bruch, können daher nicht anerkannt werden.



EN ATTENTION!
Wear protective
clothing when
handling glass!

Please examine the single-pane safety glass for possible transport damage such as chipped edges or corners immediately after unpacking. If damage is detected do not install the pane because a defect can lead to breakage later! Please make a damage report without delay! All glass panes are controlled with utmost care before packing. Therefore later complaints cannot be acknowledged, even in case of breakage.

FR ATTENTION !
Portez des
vêtements
protecteurs en
manipulant du
verre.

Merci de vérifier immédiatement le verre de sécurité monofeuille au déballage sur d'éventuels dommages survenus au transport, tels que chants et angles écaillés. Si toutefois un défaut a été constaté, merci d'en faire la déclaration au plus vite et ne pas monter la vitre, car ce défaut peut être, par la suite, à

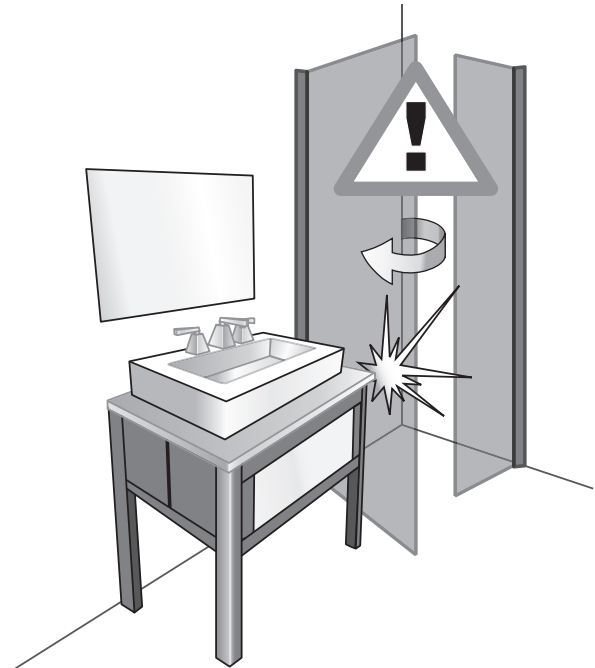

l'origine d'une casse! Tous les verres sont contrôlés minutieusement avant le conditionnement. Pour cette raison, aucune réclamation ultérieure, même en cas de casse, ne pourra être prise en compte.

Na het uitpakken het enkel veiligheidsglas (ESG) onmiddellijk op mogelijke transport- beschadigingen, zoals afgesprongen kanten of hoeken, controleren. Wordt een beschadiging vastgesteld, dan mag het glas niet worden ingebouwd, omdat deze schade ook later tot een breuk kan leiden !Bij een vastgestelde schade, meldt dit onmiddellijk! Al het glas wordt voor het verpakken zorgvuldig gecontroleerd. Latere reclames, ook bij breuk, kunnen daarom niet geaccepteerd worden.

NL ATTENTIE !
Bij het hanteren
van glas be-
schermde kle-
ding dragen!

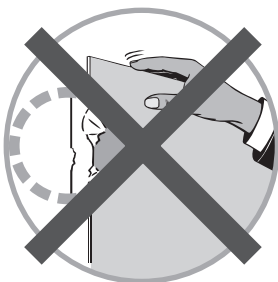

INFORMATION

INFORMATION

INFORMATION

INFORMATION

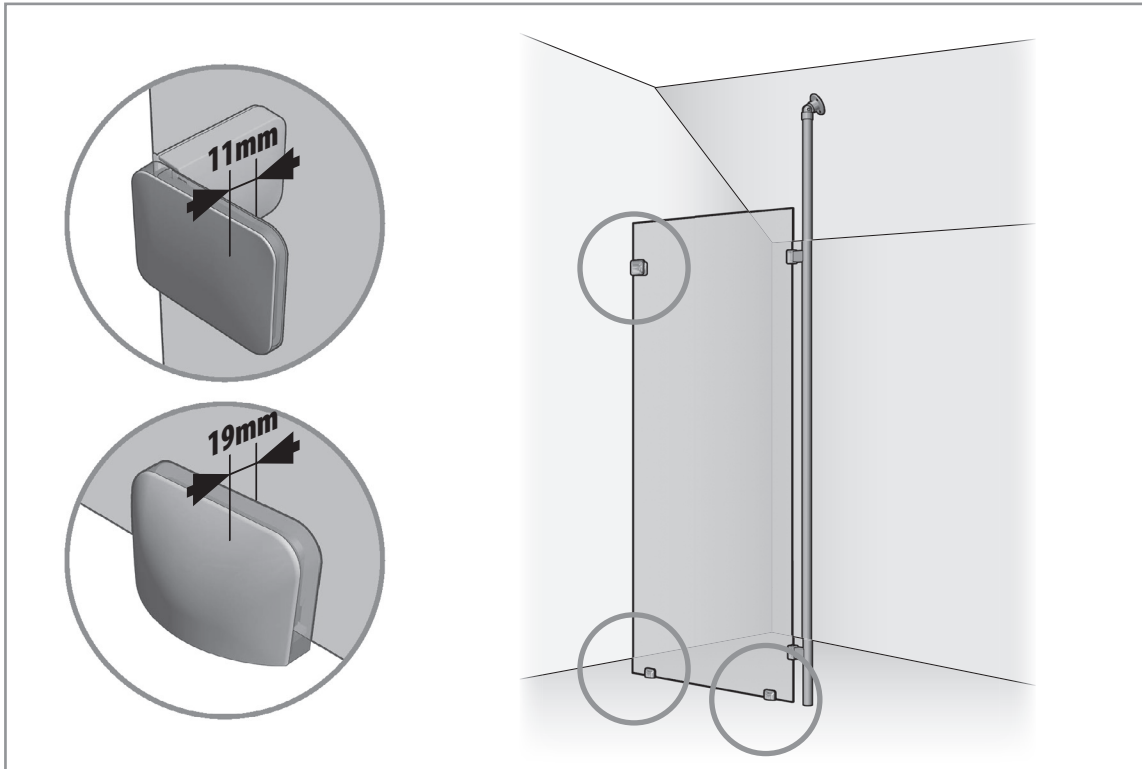









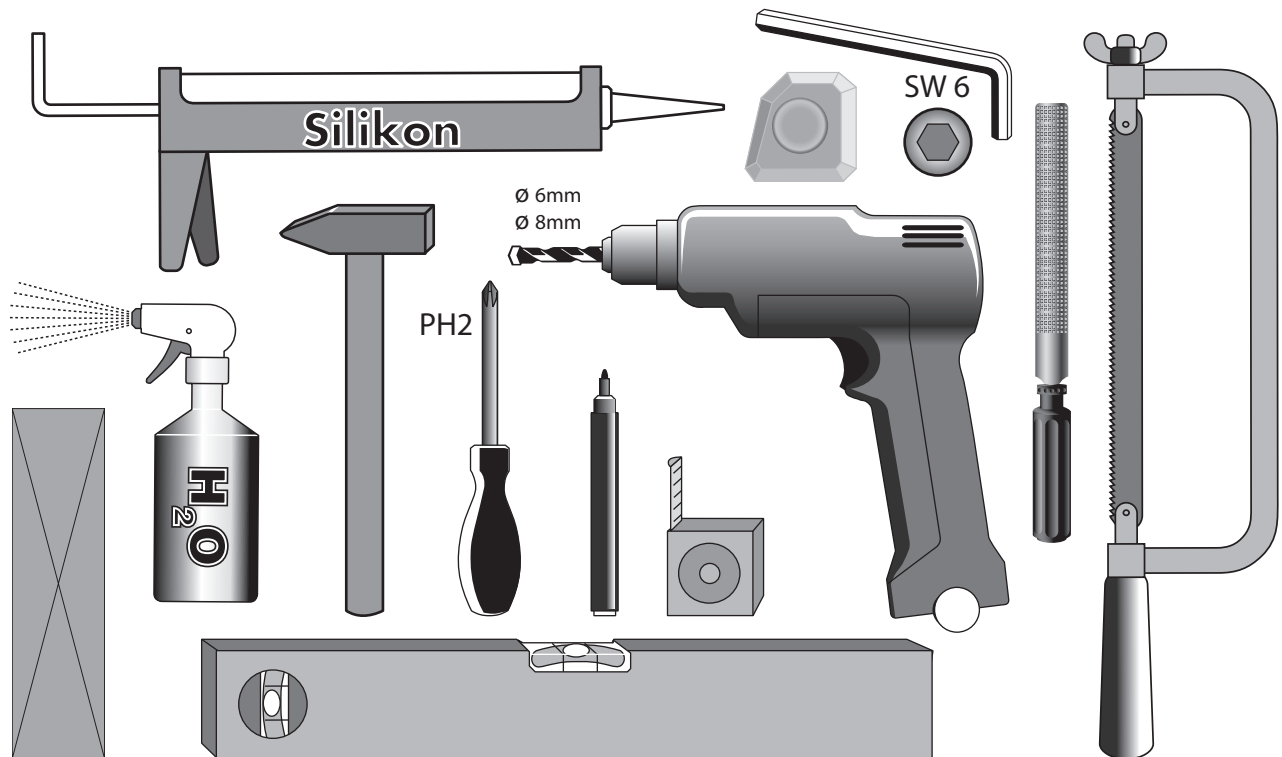



BENÖTIGTES WERKZEUG

NECESSARY TOOLS

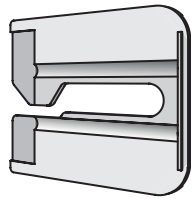
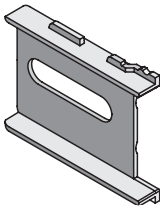
OUTILLAGE NECESSAIRE

BENODIGD GEREEDSCHAP

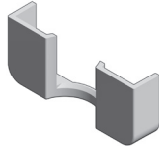
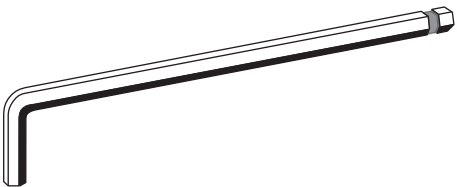
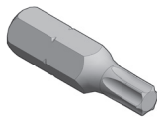
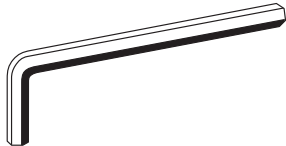

MONTAGESET	ASSEMBLY KIT	SET DE MONTAGE	MONTAGESET
<p>1x MatNr: 18896</p> 	<p>1x MatNr: 29256</p> 	<p>1x MatNr: 18401</p> 	<p>2x MatNr: 809W02</p> 
<p>2x MatNr: 705713</p> 	<p>1x MatNr: 705712</p> 	<p>1x MatNr: 705718 TP</p> 	<p>1x MatNr: 705719 TP</p> 
<p>1x 6,0 x 80 mm-T30 MatNr: 24406</p> 	<p>1x 125A-8,4-A2 MatNr: 24282</p> 	<p>3x Ø 8x50mm MatNr: 24409</p> 	<p>2x MatNr: 705606VC</p> 
<p>1x SW 4 MatNr: 18750</p> 	<p>1x TX 30 MatNr: 18881</p> 	<p>1x SW 3 MatNr: 1878</p> 	
<p>1x 6,0 x 60 mm-T30 MatNr: 24452</p> 	<p>1x Ø 8x40 mm MatNr: 24453</p> 		

MONTAGEVARIANTEN

ASSEMBLY VARIATIONS

VARIANTES DE MONTAGE

MONTAGEVARIANTEN

DE Montage ohne Duschwanne.

FR Montage sans receveur de douche.

EN Assembly without shower tray.

NL Montage zonder douchebak.

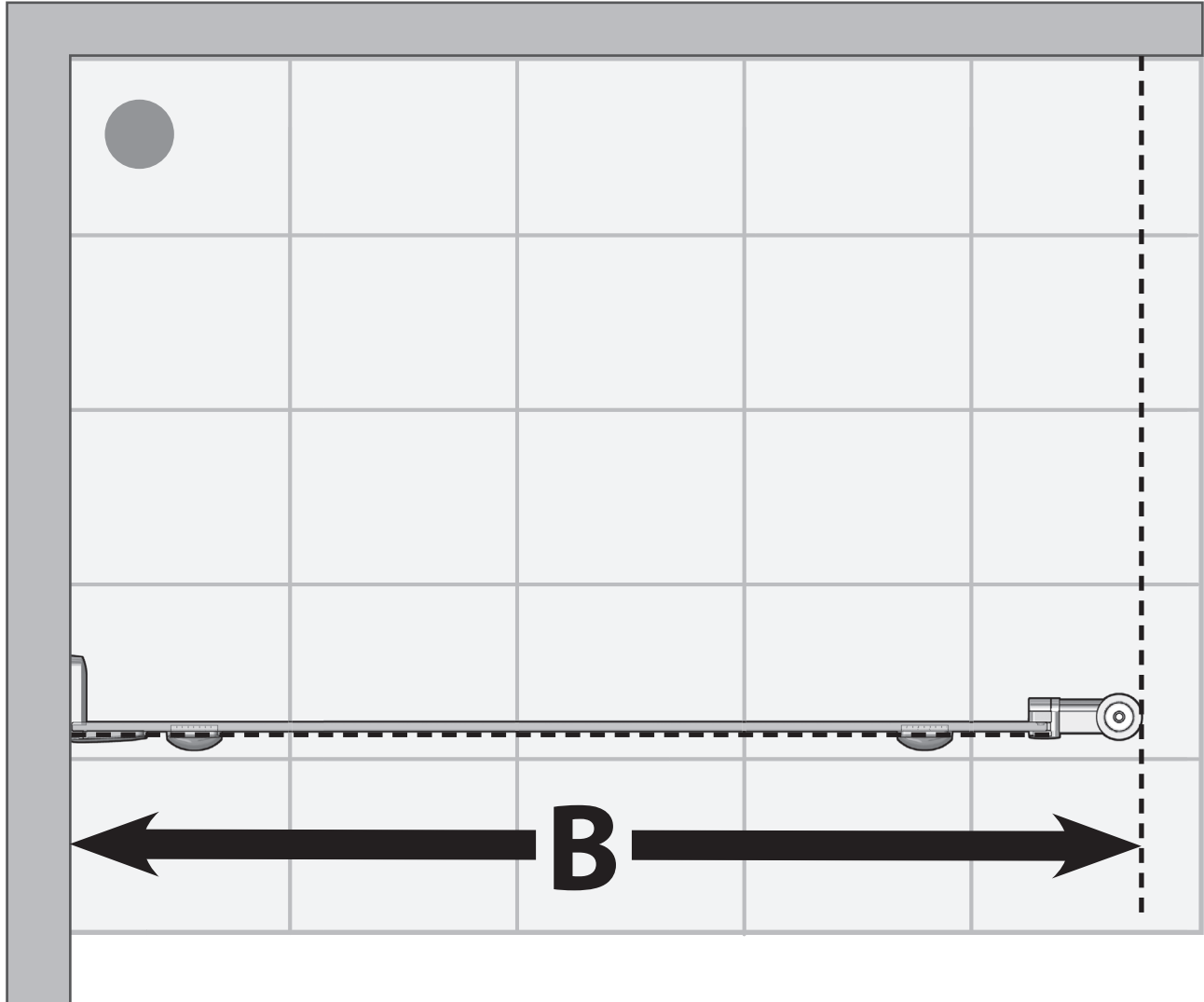

MONTAGEVARIANTEN

ASSEMBLY VARIATIONS

VARIANTES DE MONTAGE

MONTAGEVARIANTEN

DE Montage auf Duschwanne.

FR Montage sur un receveur de douche.

EN Assembly on shower tray.

NL Montage op douchebak.

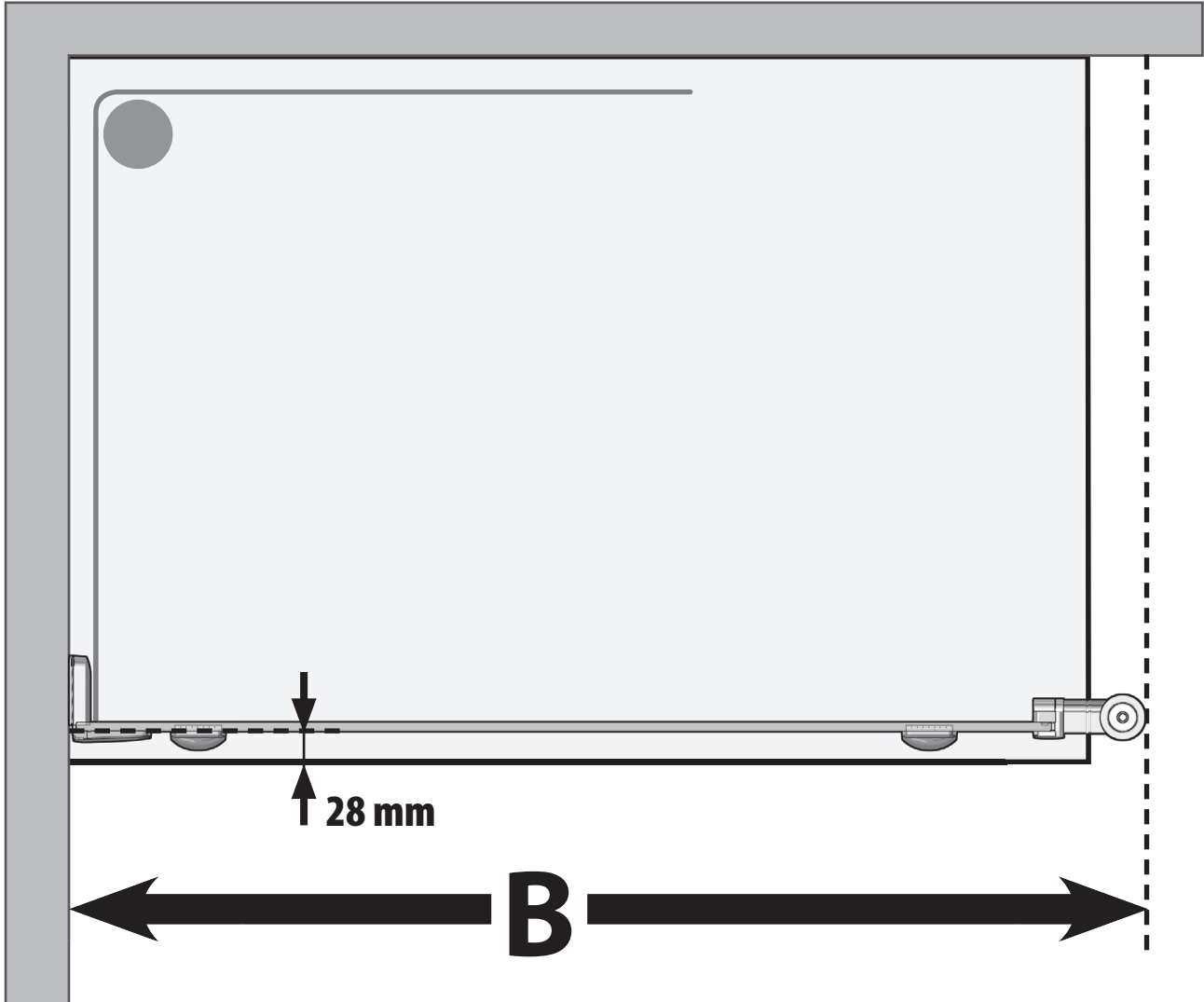

1

DE **Achtung:** Prüfen Sie vor Beginn der Montage die Größe Ihrer Duschtrennung

EN **Attention:** Before assembly check the size of your shower enclosure

FR **Attention:** Avant de débiter le montage, contrôlez la dimension de votre paroi de douche

NL **Let op:** controleert u voor montage de grootte van uw douchebalk

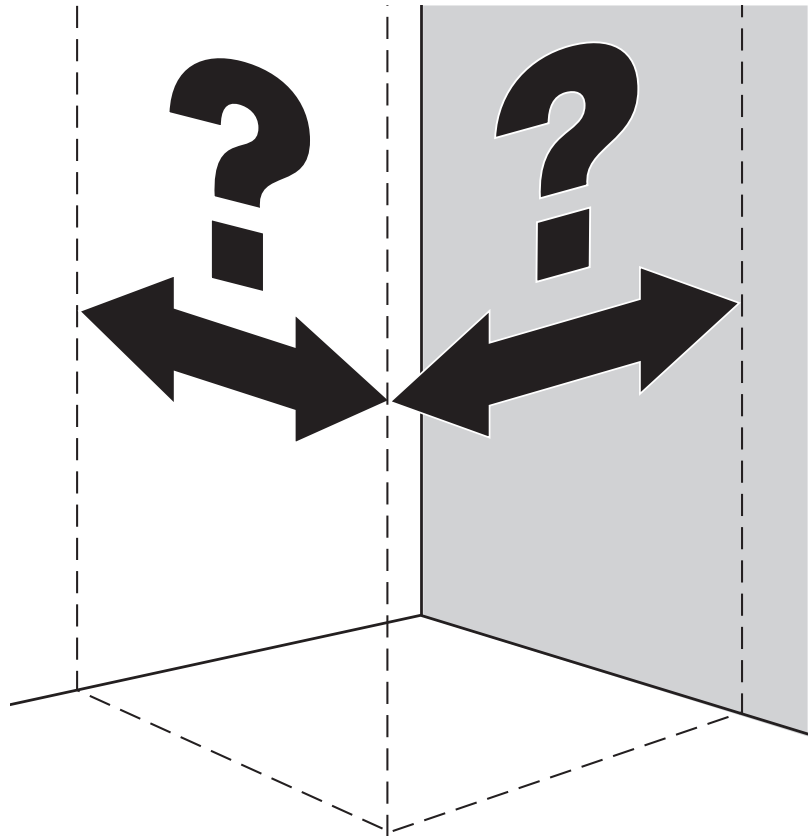

2

DE **ACHTUNG!** Eine einwandfreie Montage ist nur möglich wenn der Boden **waagrecht** und die Wände **senkrecht** sind.

EN **Attention:** Correct installation is only possible if the floor is horizontal and the walls are vertical.

FR **Attention:** Un montage impeccable n'est possible que si le sol est parfaitement plan et le murs droits. E

NL **Let op:** Een perfecte montage is alleen mogelijk, als de bodem horizontaal en de wanden verticaal t.o.v. elkaar staan.



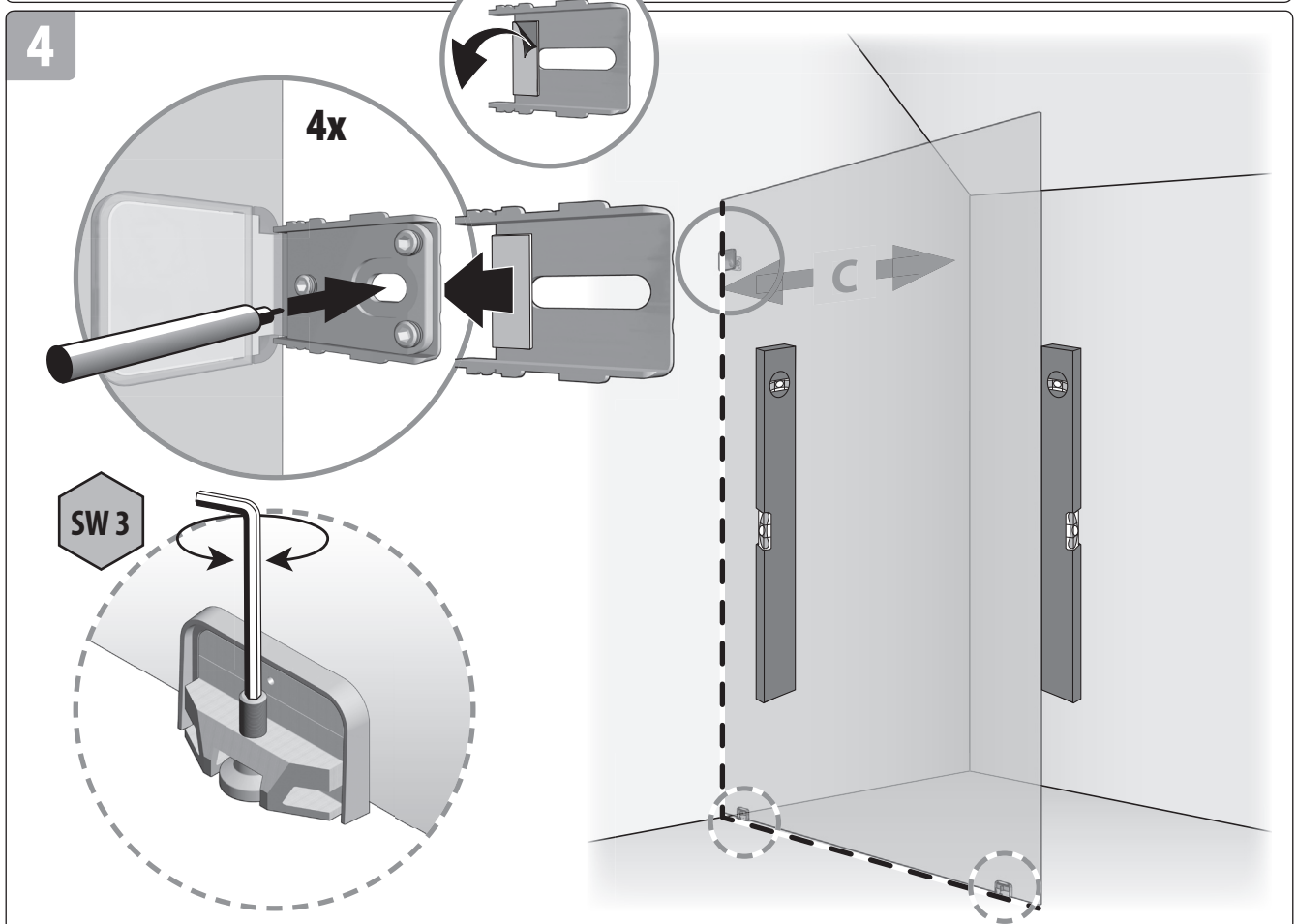
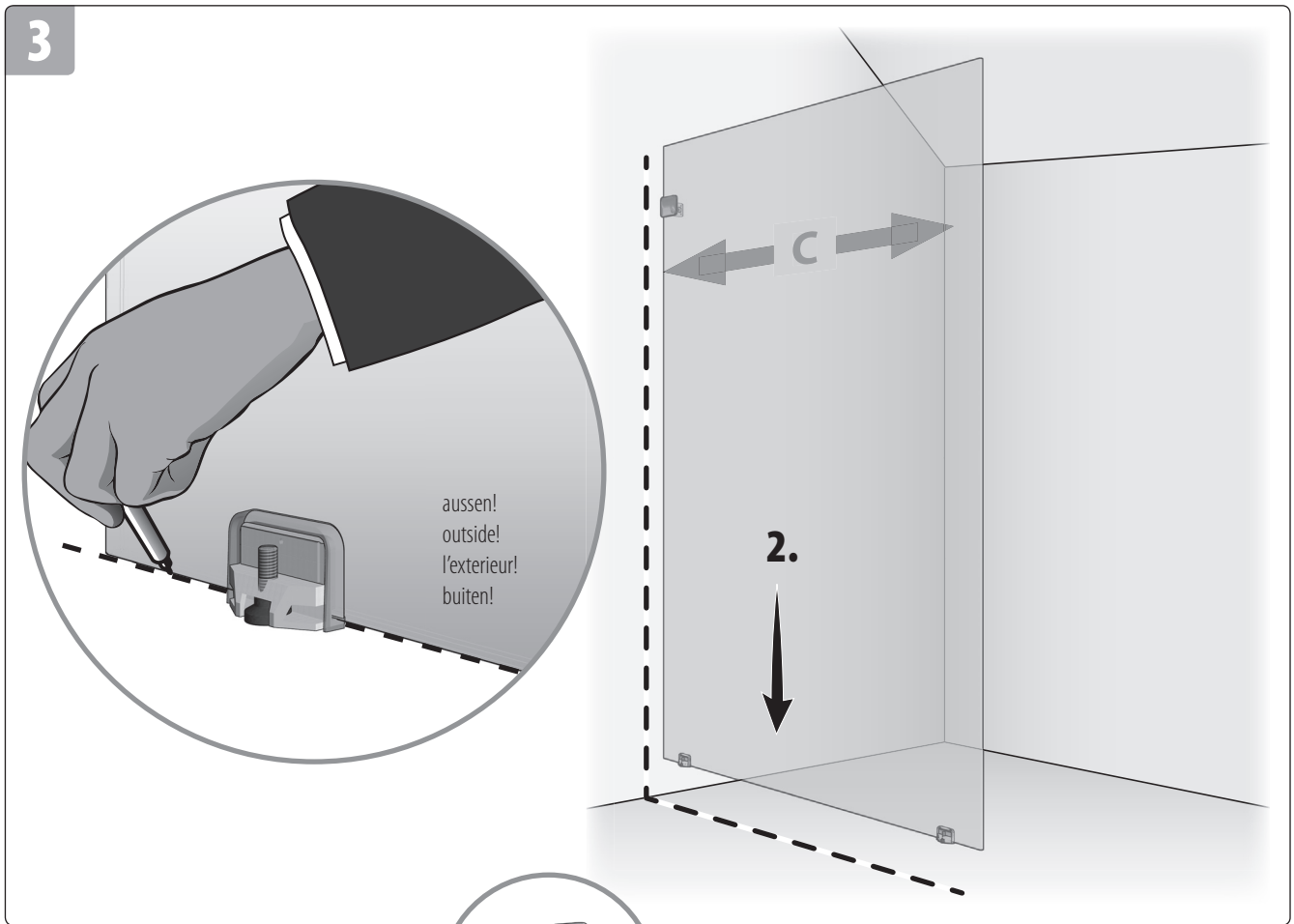

5

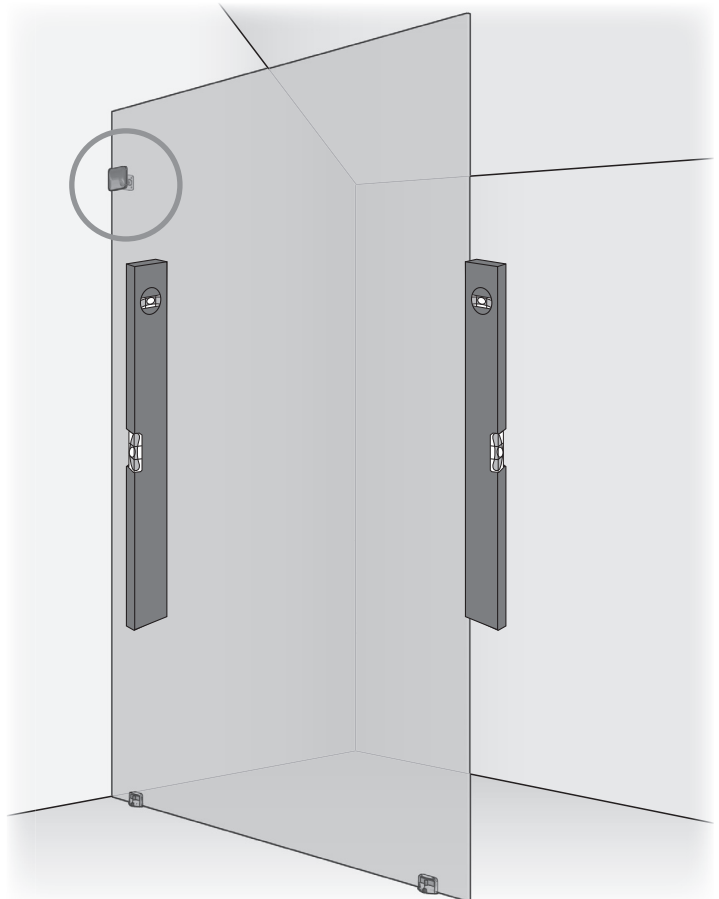
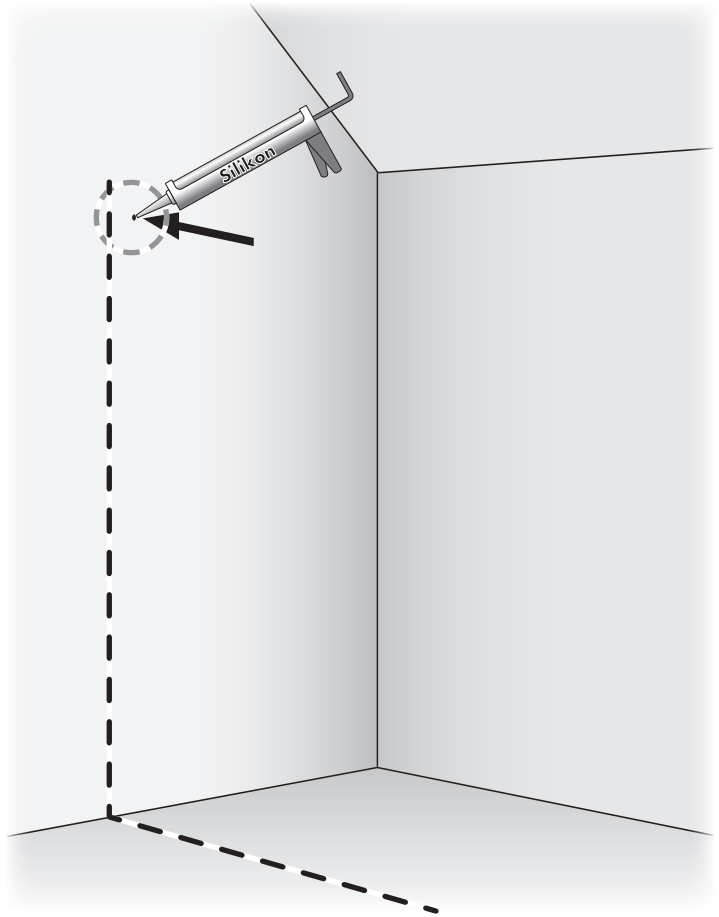
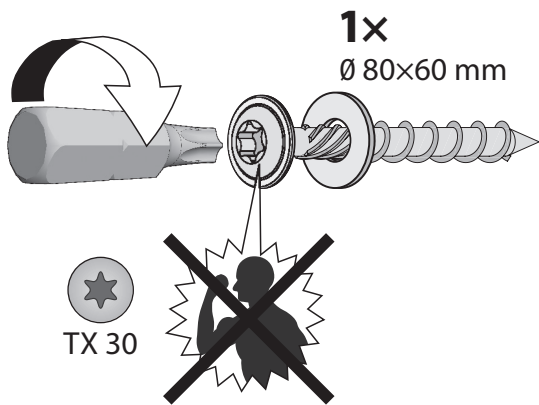
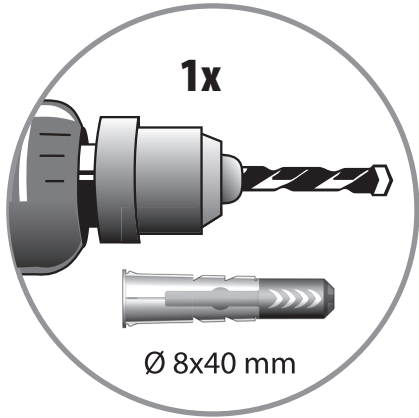

JUSTIEREN	ADJUST	AJUSTER	GOED AFSTELLEN
-----------	--------	---------	----------------

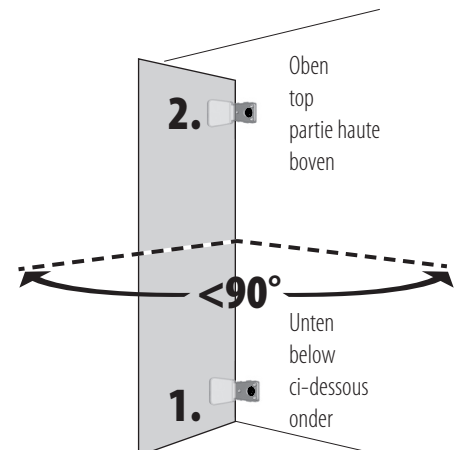
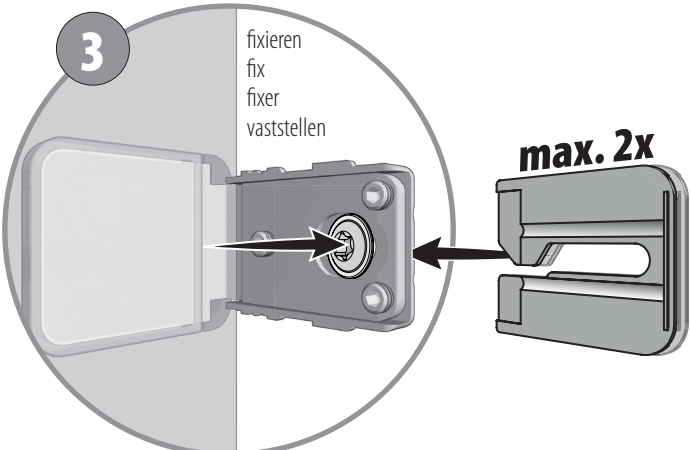
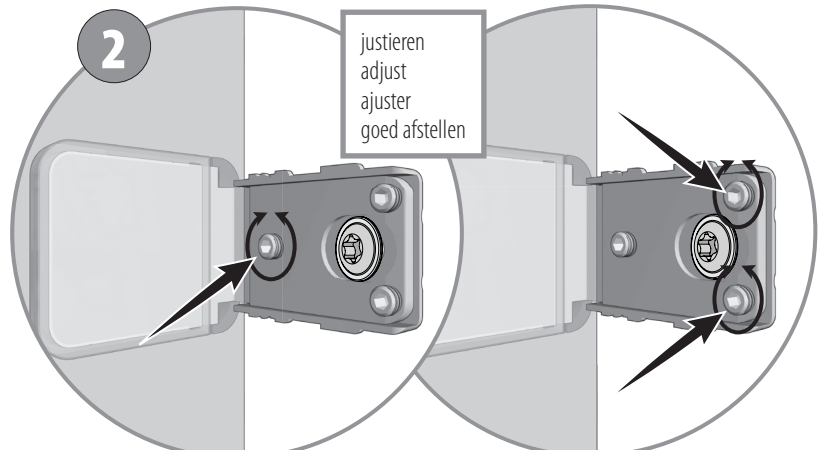
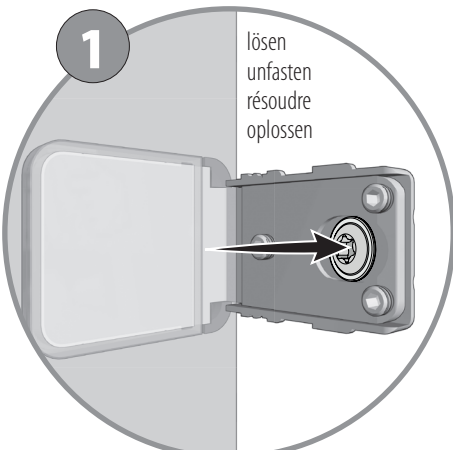
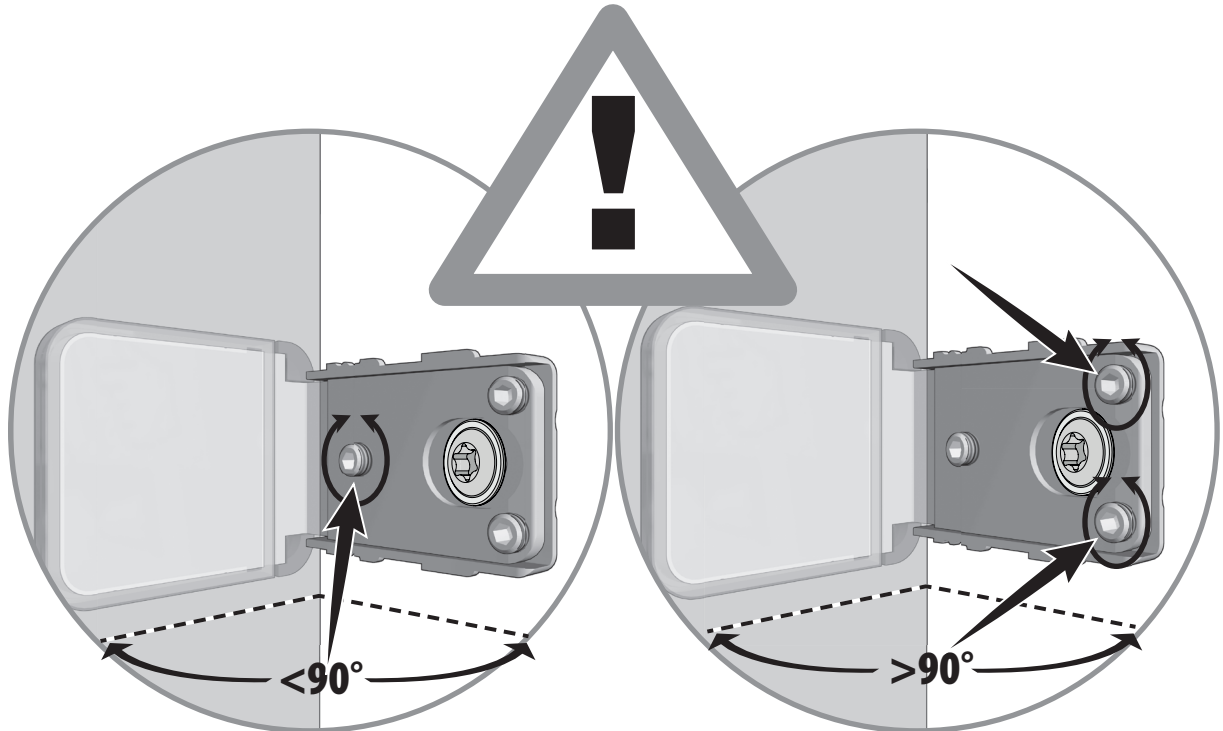

6

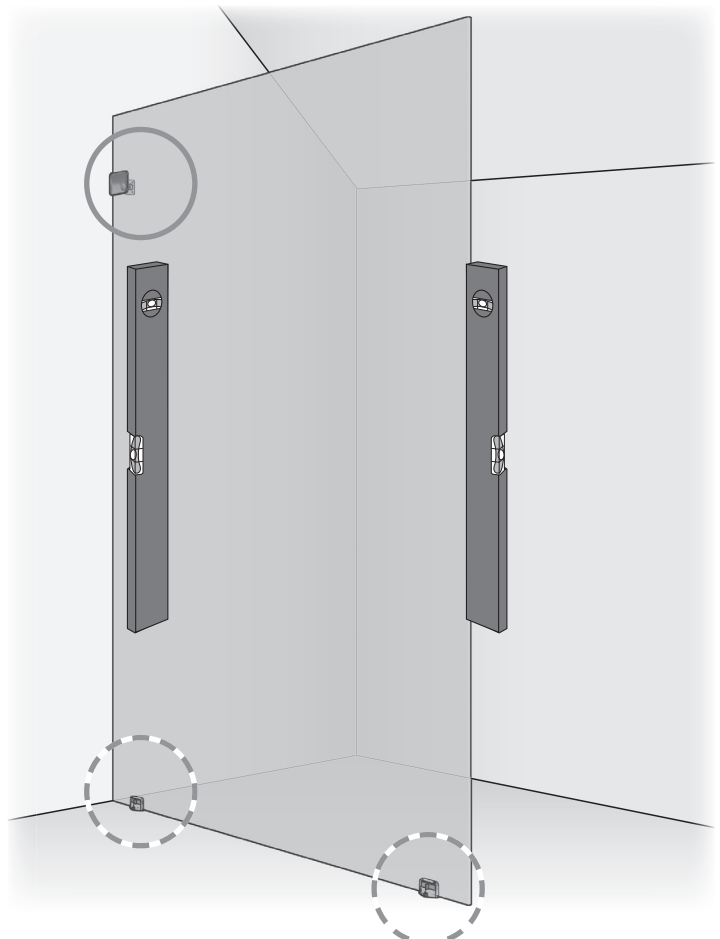
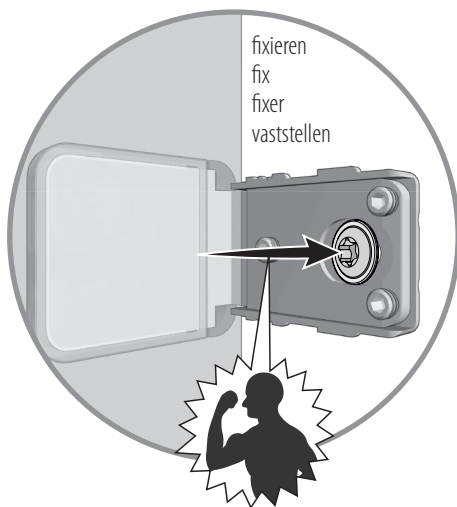
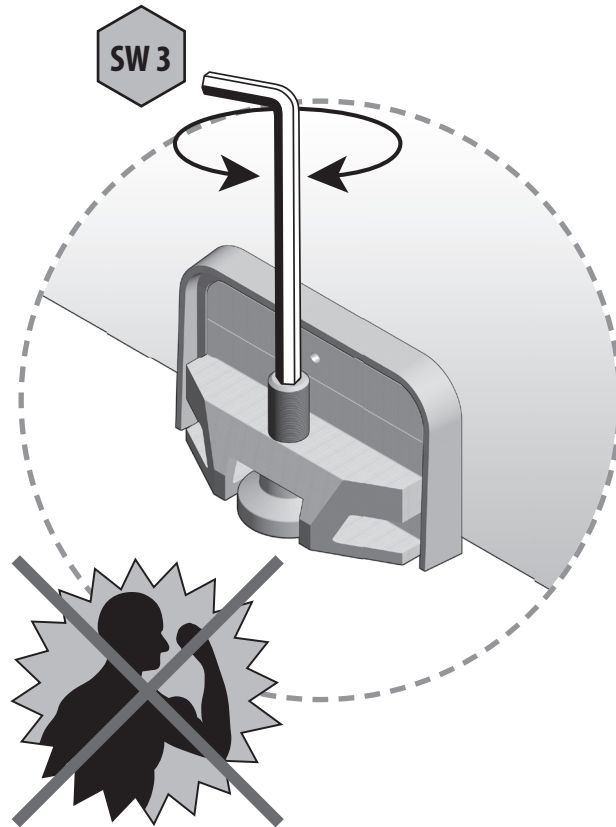

7

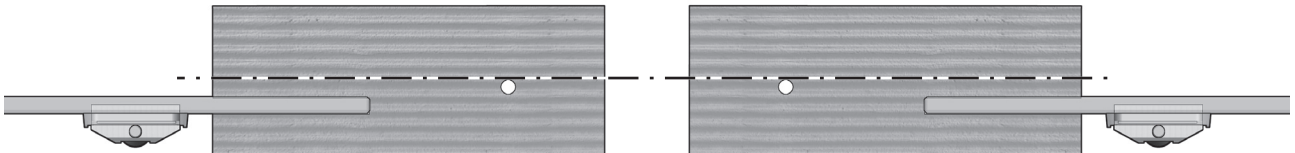

AUSSEN! Einbau links.
OUTSIDE! Installation left.
L'EXTERIEUR! Installation à gauche.
BUITEN! Inbouw links.

AUSSEN! Einbau rechts.
OUTSIDE! Installation right.
L'EXTERIEUR! Installation à droite.
BUITEN! Inbouw rechts.

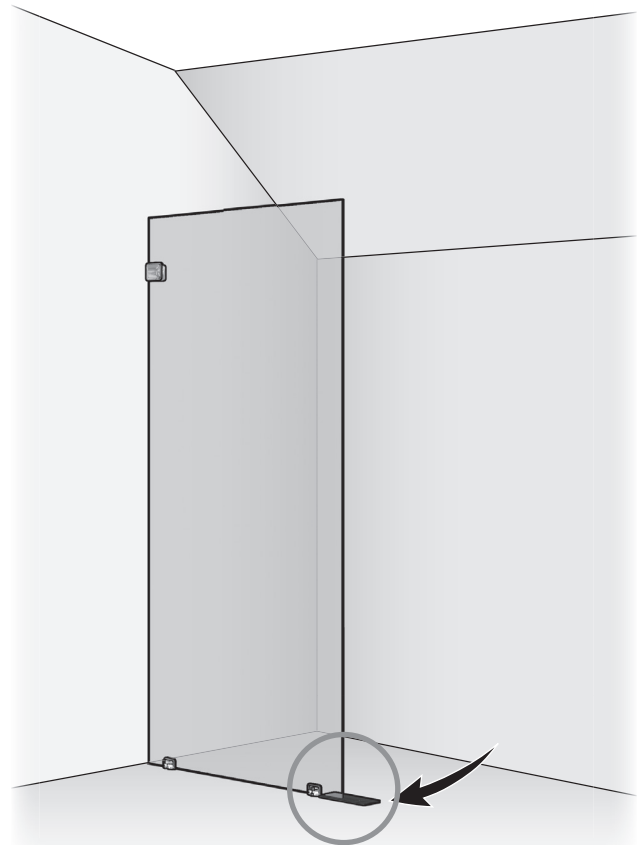
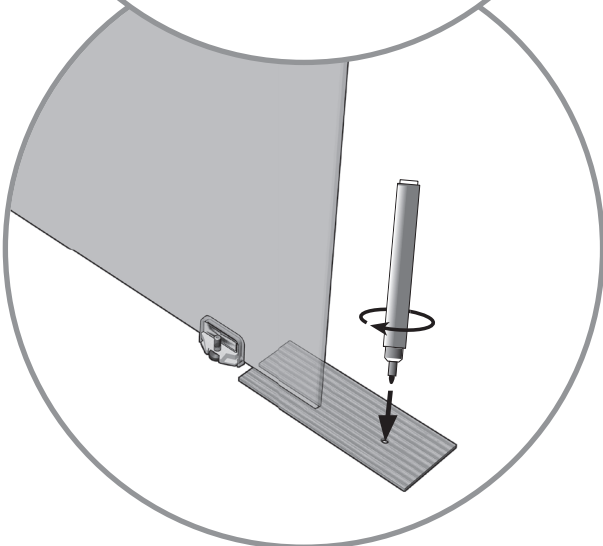
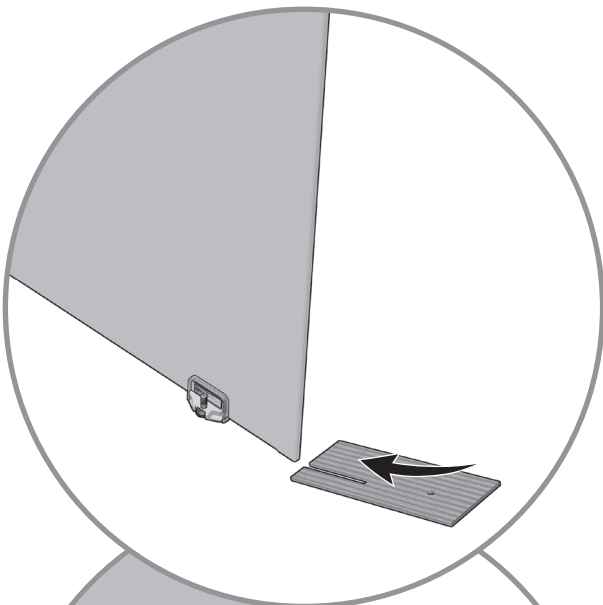

MONTAGEVARIANTEN

ASSEMBLY VARIATIONS

VARIANTES DE MONTAGE

MONTAGEVARIANTEN

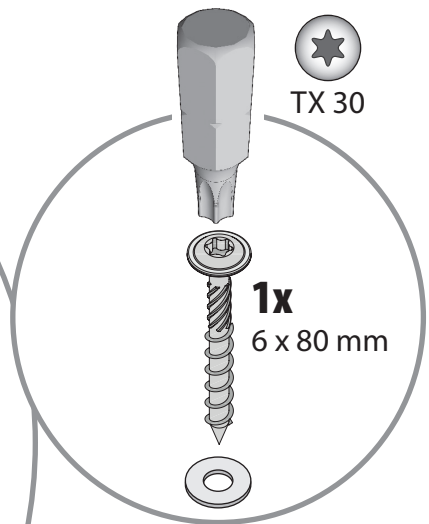
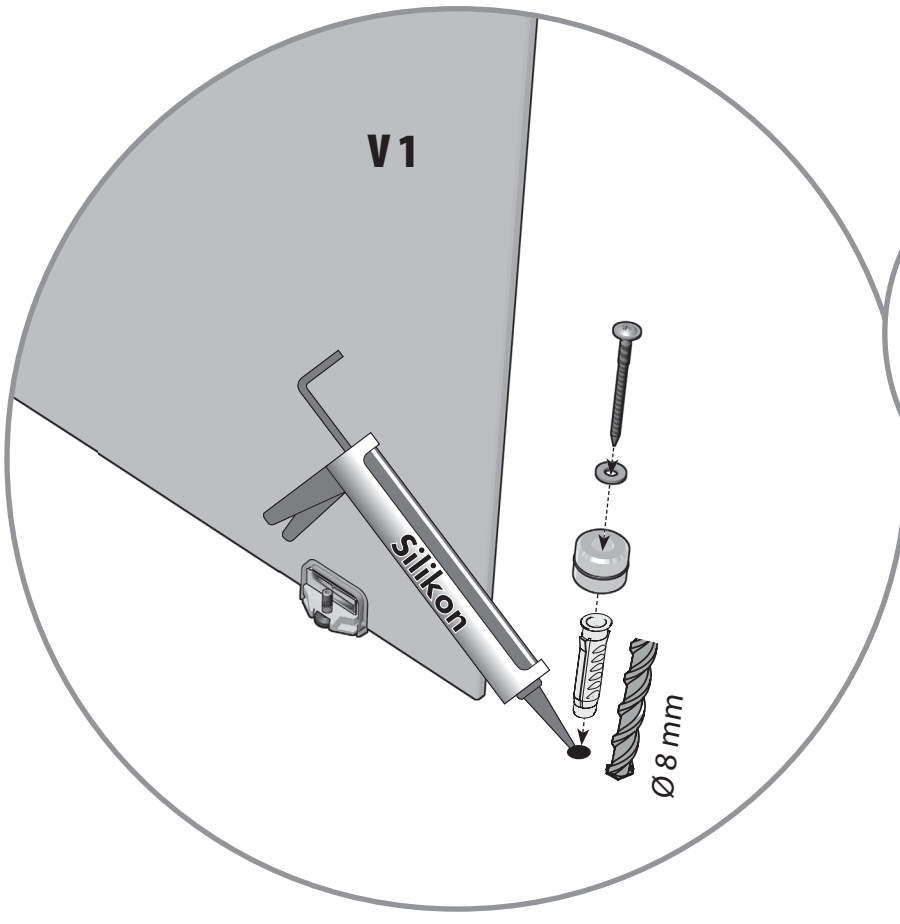
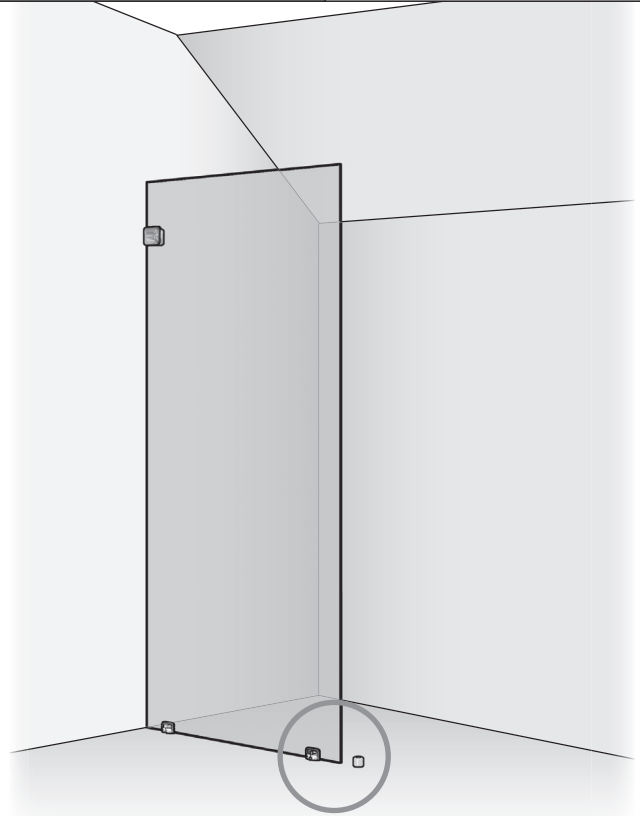
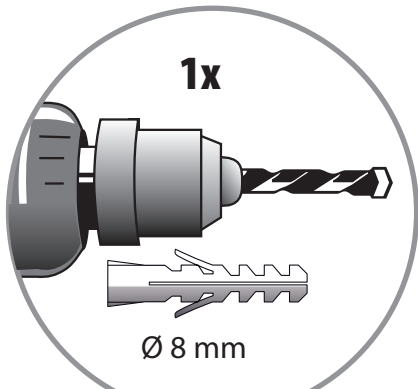

MONTAGEVARIANTEN

ASSEMBLY VARIATIONS

VARIANTES DE MONTAGE

MONTAGEVARIANTEN

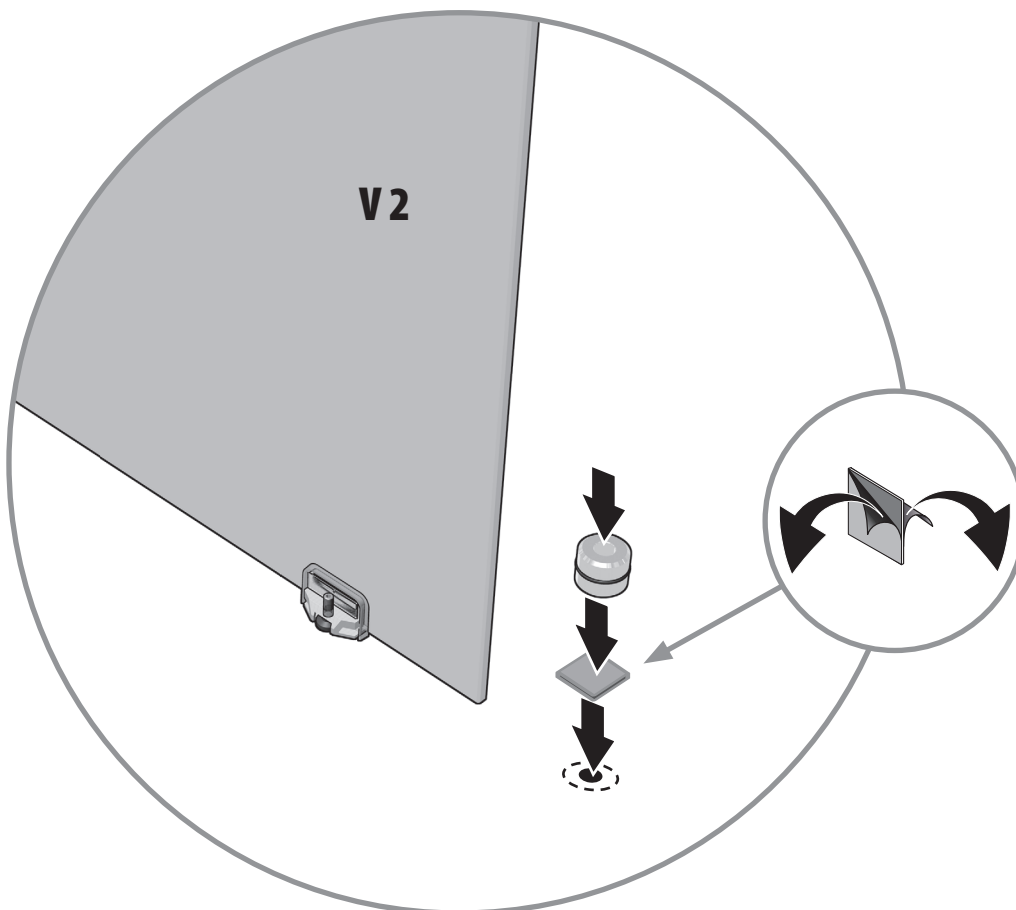
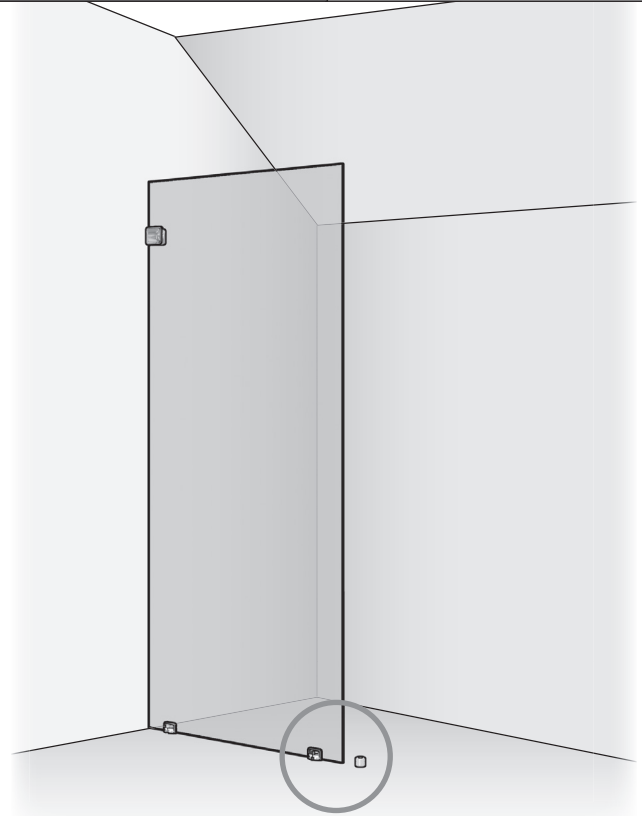

8

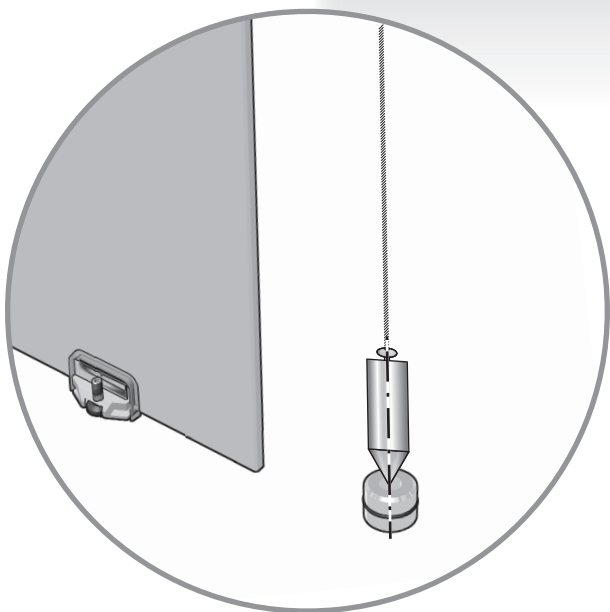
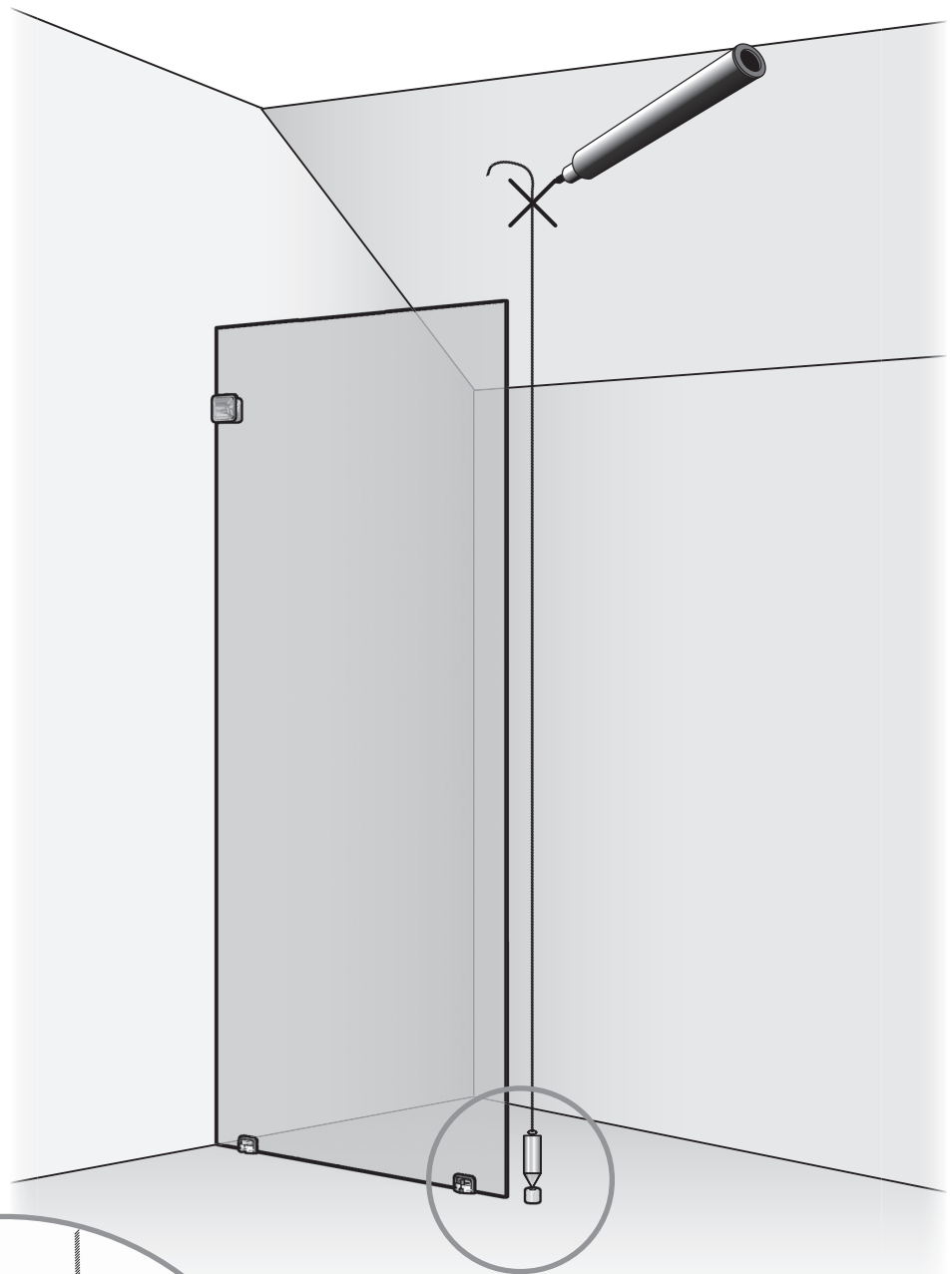

9

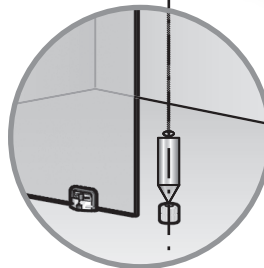
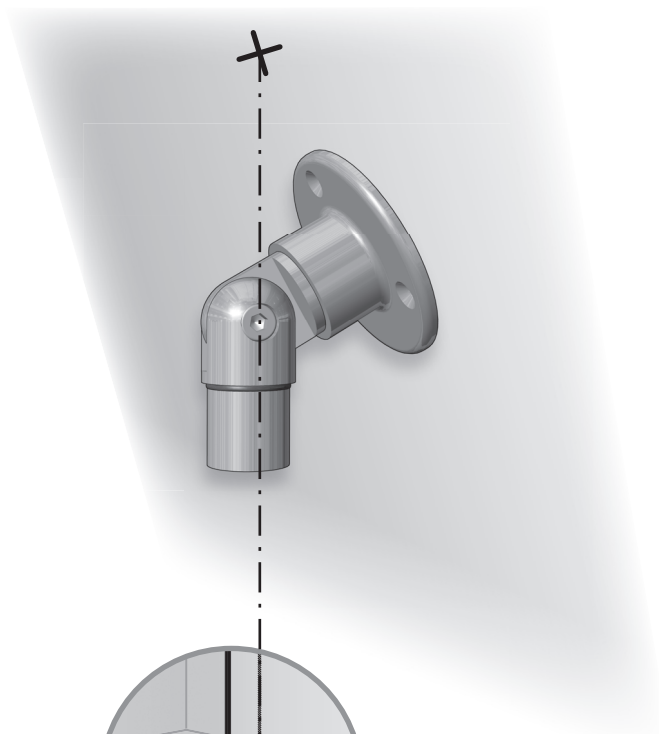
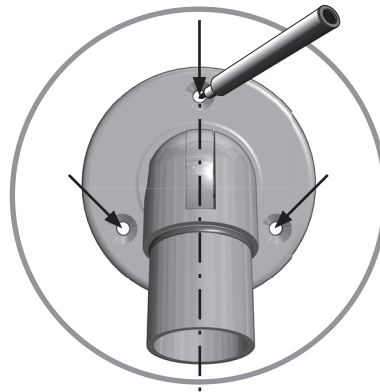
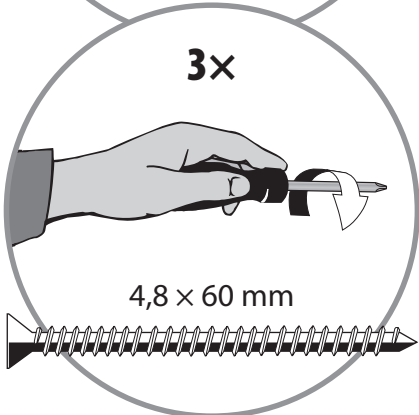
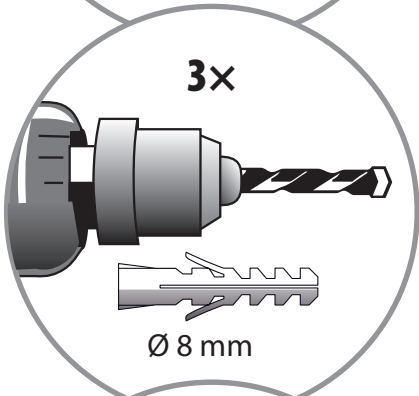

10

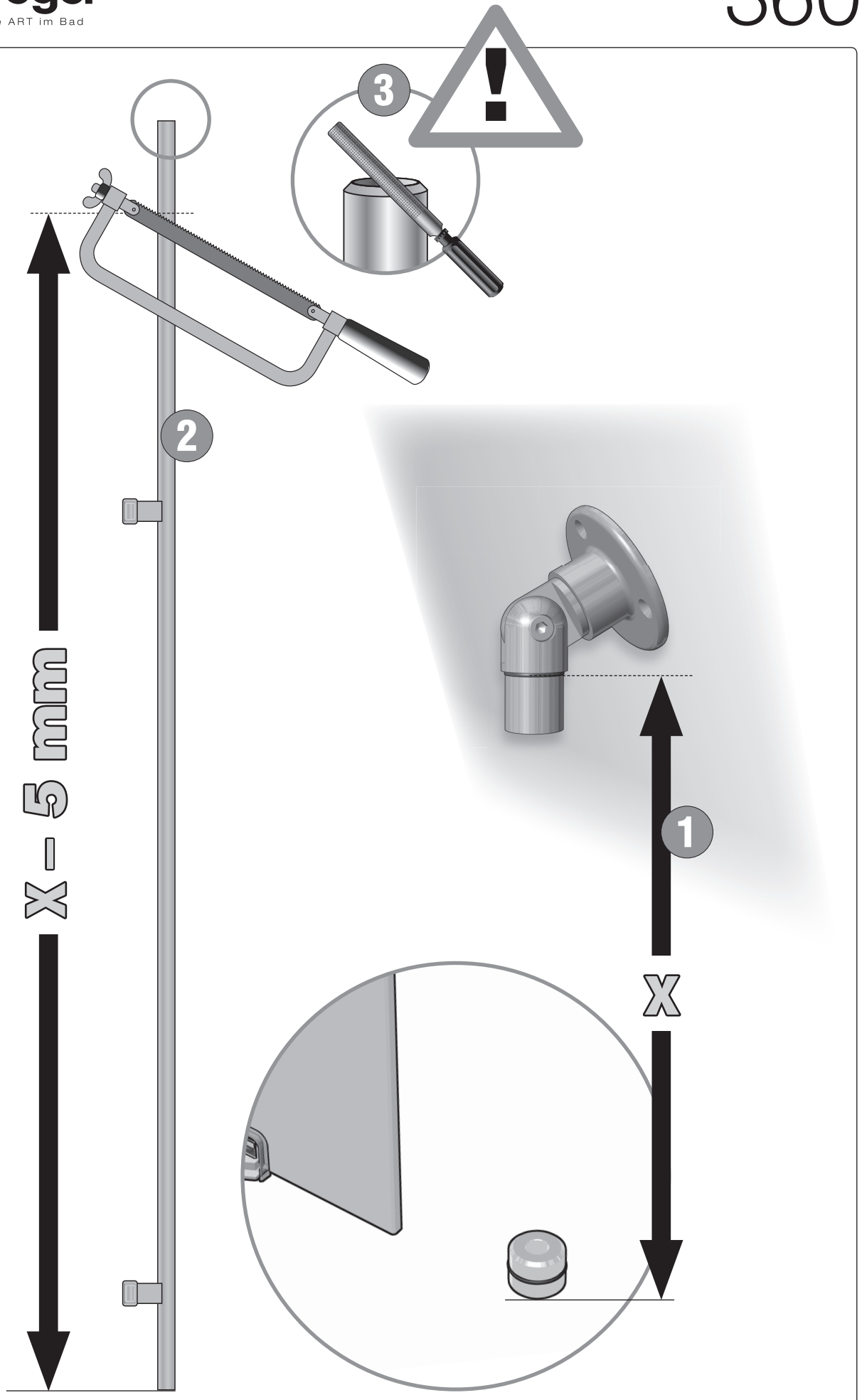

11

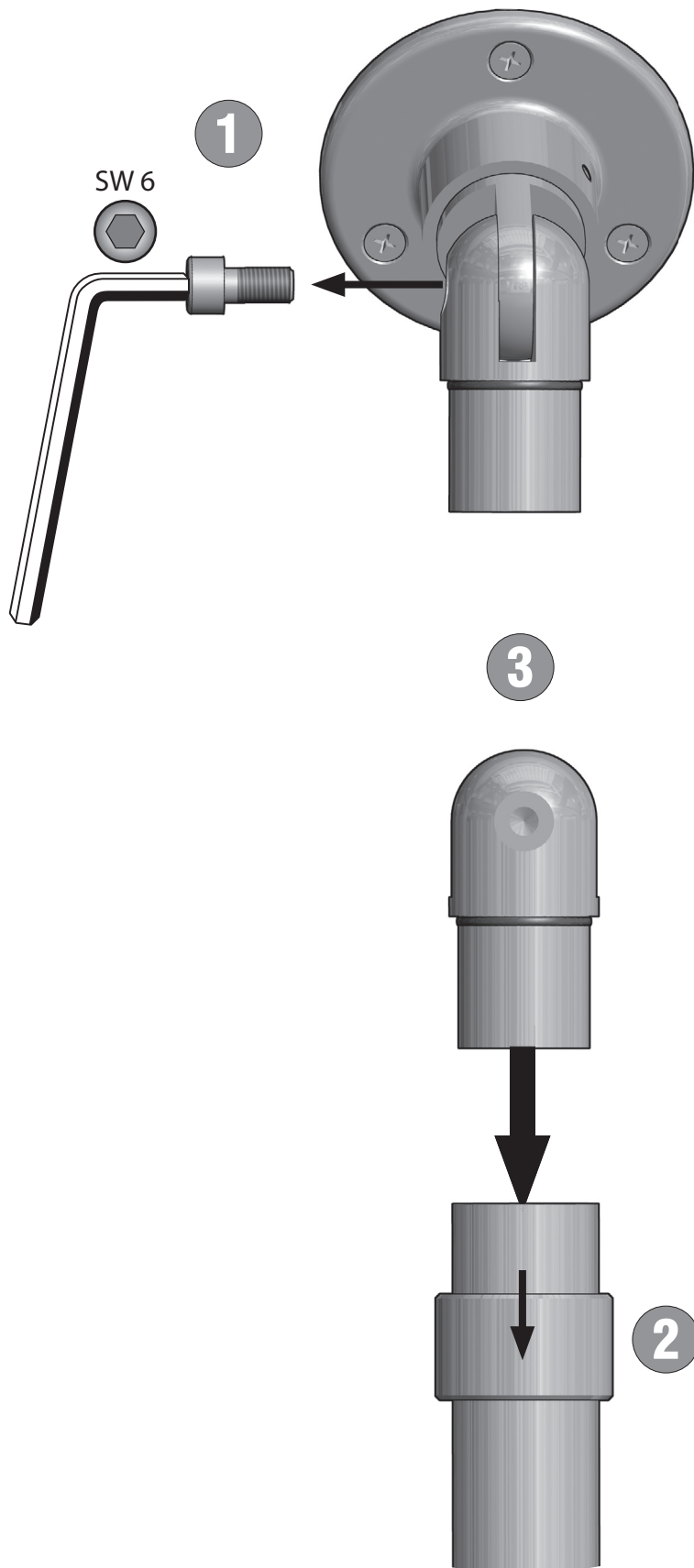

12

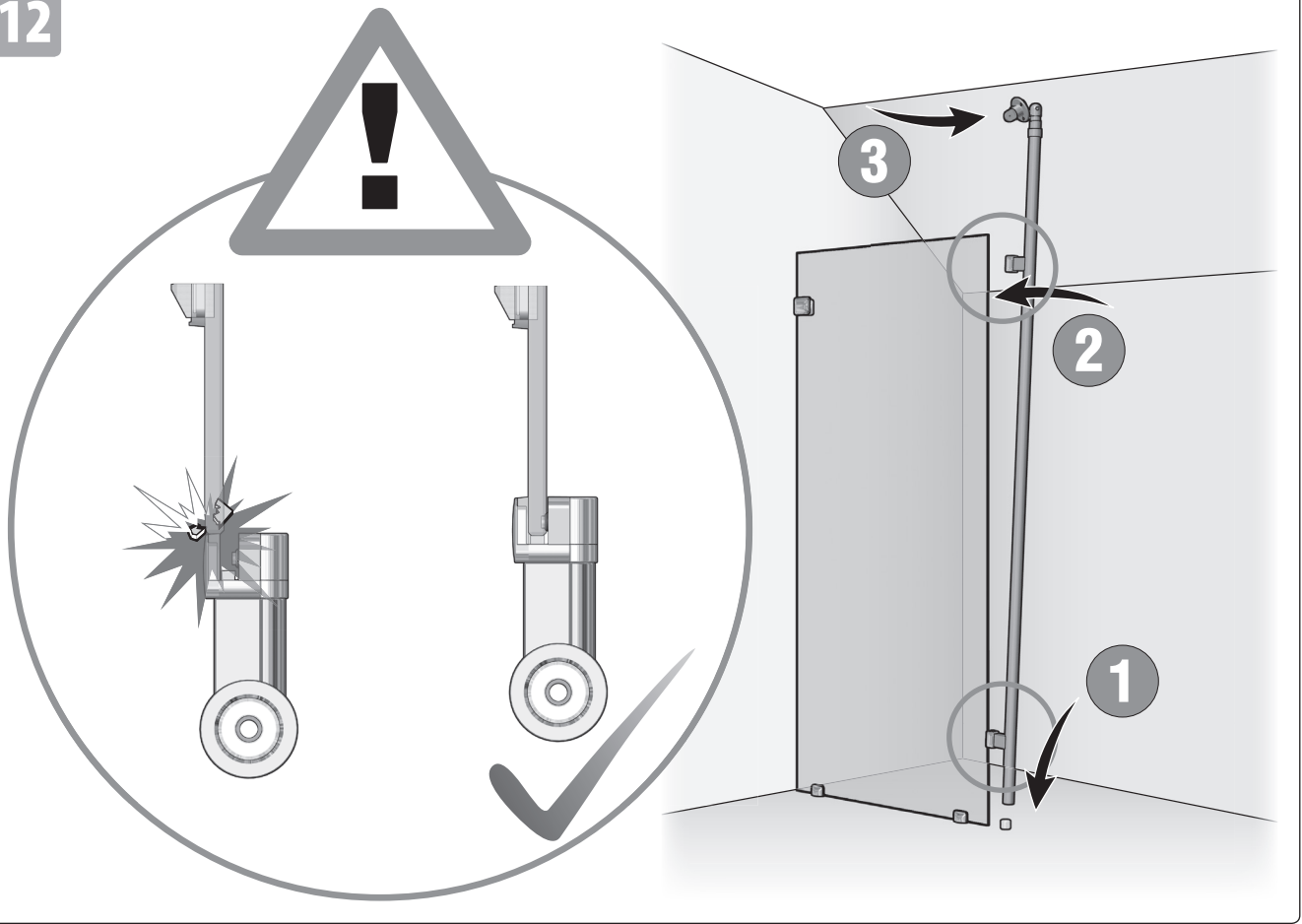

13

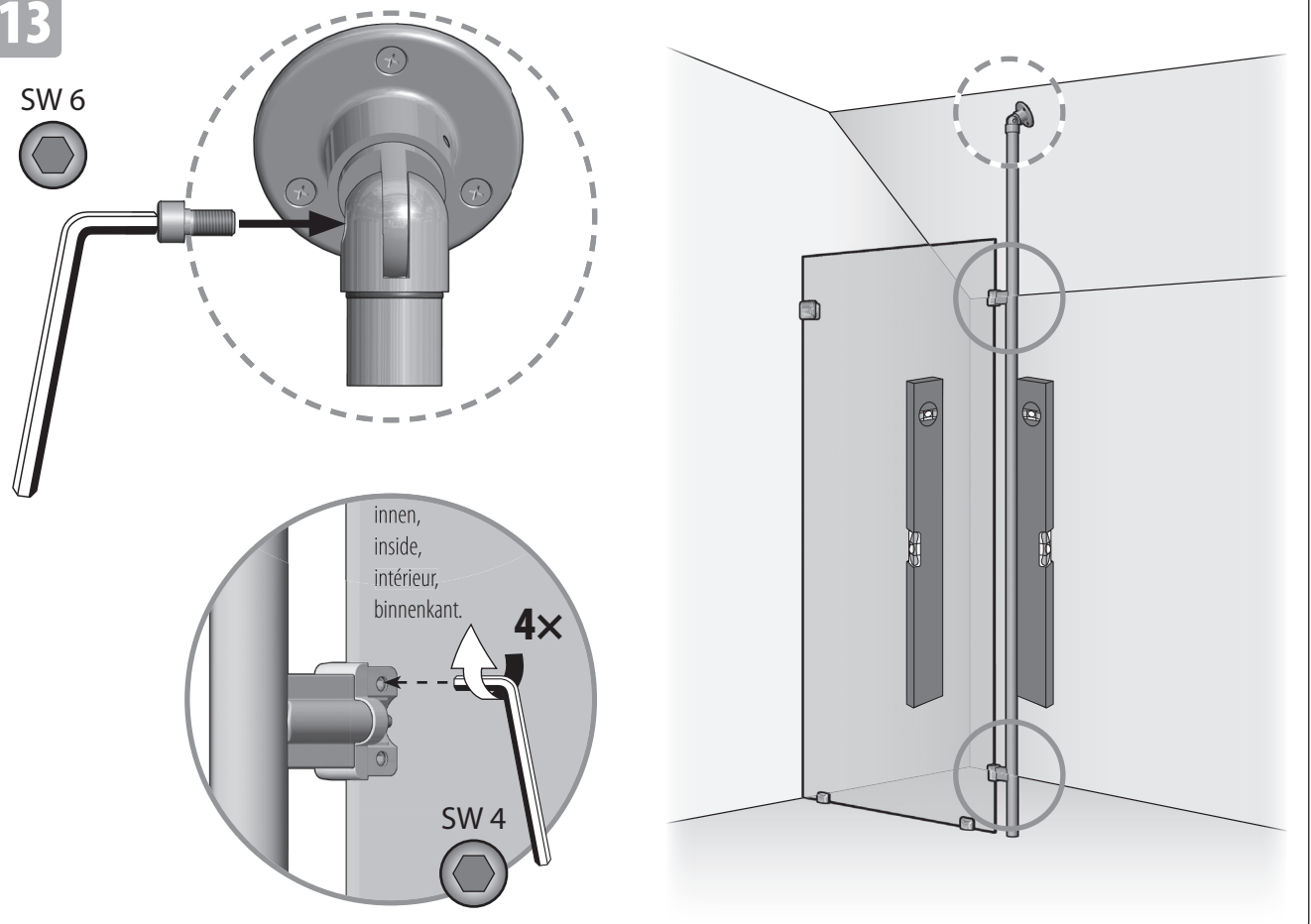

14

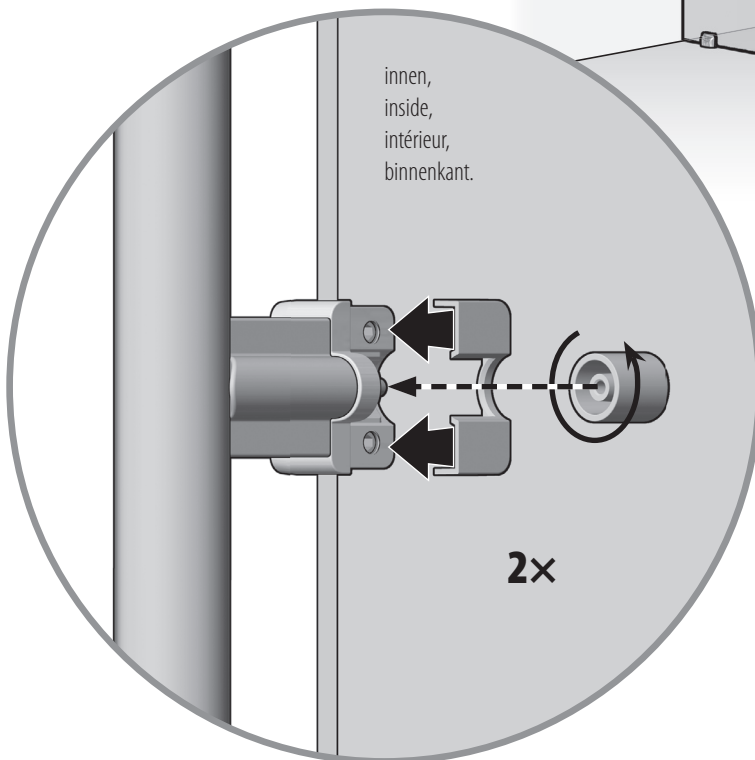
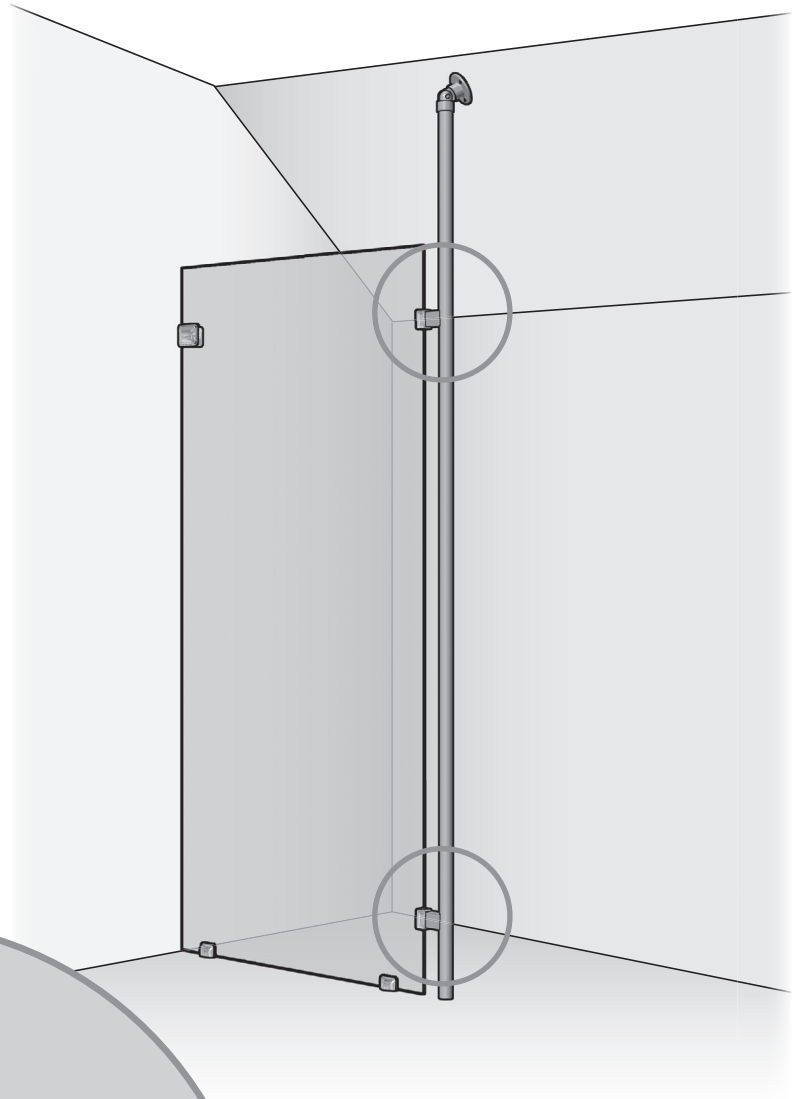

19

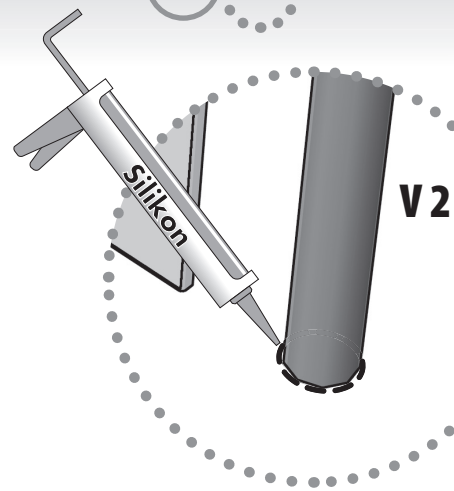
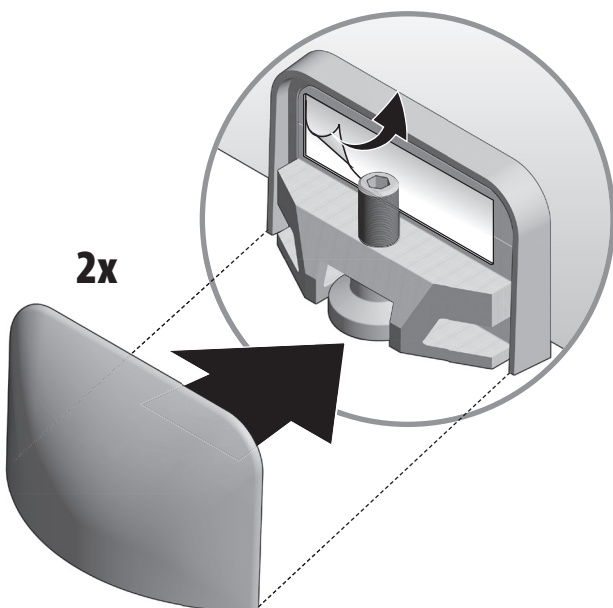
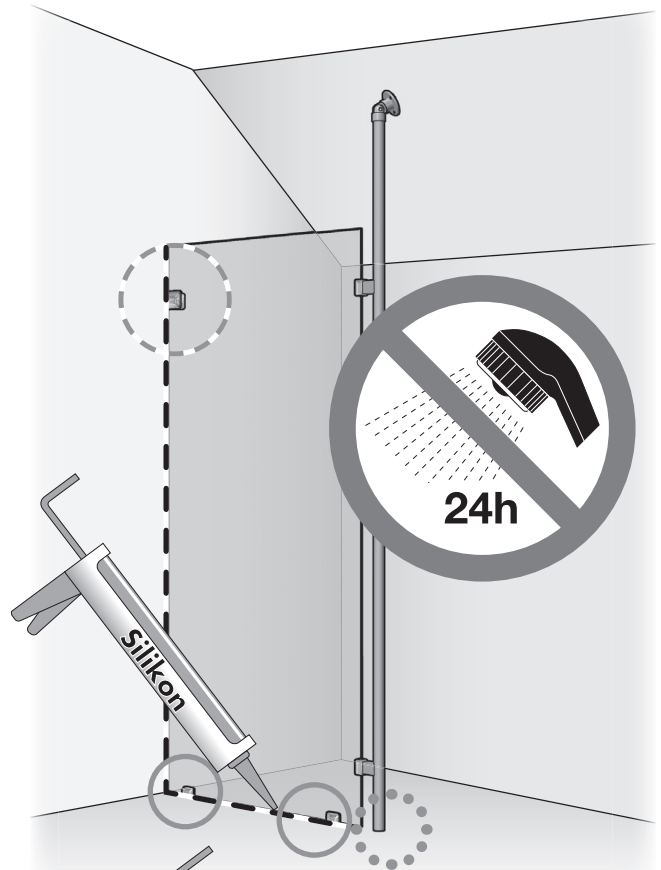
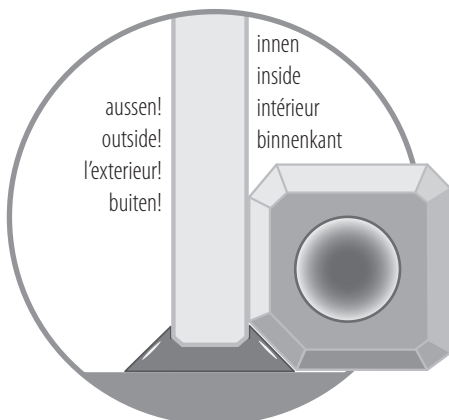
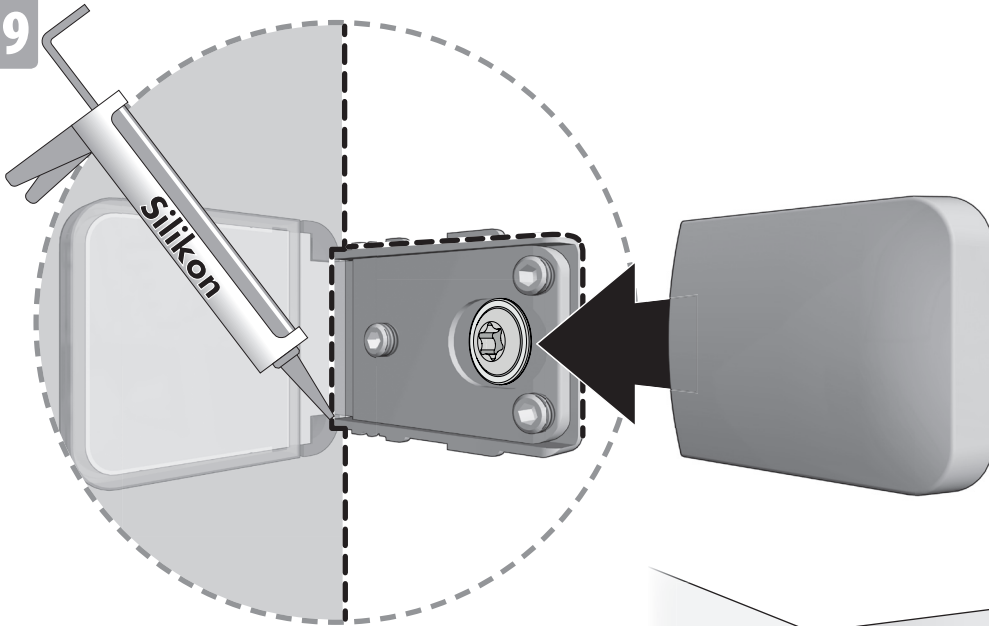

ERSATZTEILE

SPARE PARTS

PIÈCES DÉTACHÉES

ONDERDELEN

Artweger GmbH. & Co. KG

Sulzbacherstraße 60 | 4820 Bad Ischl | Austria
Tel. +43 6132 205-0 | Fax +43 6132 205-5000
info@artweger.at | www.artweger.at

Niederlassung Wien

Goldschlagstraße 178 | 1140 Wien | Austria
Tel. Schauraum +43 1 9142753-11
Tel. Auftragsabwicklung +43 6132 205-25
Fax +43 1 9142753-22
wien@artweger.at

Verkauf Deutschland

Artweger GmbH. & Co. KG
Postfach 1169 | 83402 Ainring | Deutschland
Tel. 0800 1114442-0 | Fax 0800 1114442-41
info@artweger.de | www.artweger.de

Verkauf Schweiz

Artweger GmbH. & Co. KG
Postfach 16 | CH-4202 Duggingen
Tel. + 41 61 751 90 91
info@artweger.com | www.artweger.com



Druck- und Satzfehler sowie technische Änderungen vorbehalten.
Typographical errors and technical changes reserved.
Sous réserve d'erreurs d'impression ou de syntaxe ainsi que de modifications techniques.
Drukfouten, maatwijzingen en technische veranderingen voorbehouden.
Ci riserviamo errori di stampa e variazioni tecniche.