

MONTAGEANLEITUNG
EckEinstieg, gerahmt

MGE0 ..

ASSEMBLY INSTRUCTIONS
Corner entry, with frame

NOTICE DE MONTAGE
Accès d'angle, avec cadre

MONTAGEVOORSCHRIFT
Hoekinstap, met profiel

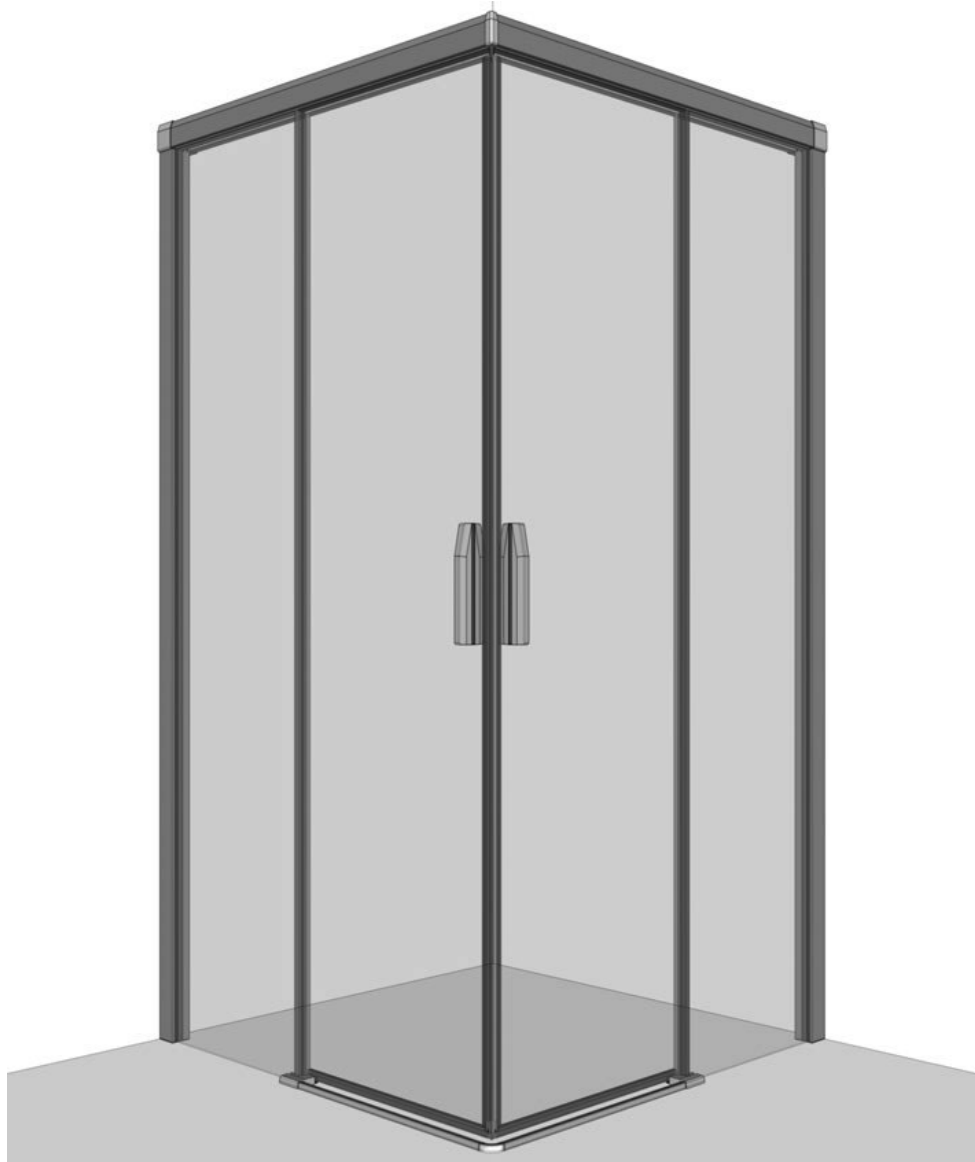

Vor Gebrauch sorgfältig lesen! Zum Nachschlagen und Aufbewahren dem Endkunden übergeben!

Read carefully before use! Hand over to the customer for looking up and storage!

Avant emploi lire soigneusement! Remettez le au client pour la recherche et le stockage!

Voordien gebruik zorgvuldig lezend! Overhandig de klant voor het kijken omhooggaand en opslag!

DEUTSCH
Originalsprache

ENGLISH
Translation

FRANCAIS
Traduction

NEDERLANDS
Translation

INHALTSVERZEICHNIS

OVERVIEW

INHALTSVERZEICHNIS 2

SICHERHEITS-HINWEISE..... 4

BENÖTIGTES WERKZEUG 6

MONTAGESET 7

MONTAGEVARIANTEN 8

VERSTELLBEREICH 8

MONTAGEVARIANTEN 9

**WANNEN-
EINBAUMASS 9**

MONTAGE 10

 » MONTAGE FIXTEIL 10

 » MONTAGE TÜR..... 15

 » MONTAGE DICHTLEISTEN 19

 » MONTAGE GRIFF 20

 » ABDICHTEN MIT SANITÄRSILIKON 22

ERSATZTEILE..... 23

OVERVIEW 2

SAFETY INSTRUCTONS..... 4

NECESSARY TOOLS 6

ASSEMBLY KIT 7

ADJUSTMENT RANGE 8

ASSEMBLY VARIATIONS..... 8

MONTAGEVARIANTEN..... 9

**TRAY INSTALLATION-
MASUREMENT 9**

ASSEMBLY 10

 » INSTALLATION OF IMMOVABLE ELEMENT 10

 » INSTALLATION DOOR..... 15

 » INSTALLATION OF SEALING STRIP 19

 » INSTALLATION OF HANDLE..... 20

 » SEALING WITH SANITARY SILICONE 22



SPARE PARTS..... 23

VUE D'ENSEMBLE

VUE D'ENSEMBLE.....	2
INSTRUCTIONS SÉCURIT.....	4
OUTILLAGE NECESSAIRE.....	6
SET DE MONTAGE.....	7
VARIANTES DE MONTAGE.....	8
POSITIONNEMENT.....	8
VARIANTES DE MONTAGE.....	9
VARIANTES DE MONTAGE SUR RECEVEUR.....	9
MONTAGE.....	10
» MONTAGE PARTIE FIXE.....	10
» MONTAGE DE LA PORTE.....	15
» MONTAGE BAGUETTES D'ÉTANCHÉITÉ.....	19
» MONTAGE POIGNÉE.....	20
» ETANCHER AVEC DU SILICONE SANITAIRE.....	22
PIÈCES DÉTACHÉES.....	23

OVERZICHT

OVERZICHT.....	2
VEILIGHEIDS VOORSCHRIFTEN.....	4
BENODIGD GEREEDSCHAP.....	6
MONTAGESET.....	7
MONTAGEVARIANTEN.....	8
VERSTELBAARHEID.....	8
MONTAGEVARIANTEN.....	9
DOUCHEBAK- INBOUWMAAT.....	9
MONTAGE.....	10
» MONTAGE VAST DEEL.....	10
» MONTAGE DEUR.....	15
» MONTAGE AFDICHTEN.....	19
» MONTAGE GREEP.....	20
» AFDICHTENMET SANITAIR-SILICONEN.....	22
ONDERDELEN.....	23

SICHERHEITS- HINWEISE	SAFETY INSTRUCTIONS	INSTRUCTIONS SÉCURIT	VEILIGHEIDS VOORSCHRIFTEN
<p>DE Vor dem Einbau bitte unbedingt beachten!</p> <ul style="list-style-type: none"> • Produkt vor dem Einbau, auf Richtigkeit, Beschädigungen und das Zubehör auf Vollständigkeit überprüfen. • Bei sichtbarem Schaden Produkt keinesfalls einbauen! • Beachten Sie beim Hantieren das teilweise hohe Gewicht und/oder die großen Abmessungen von Einzelteilen. • Beachten Sie beim Bohren der Löcher, dass Sie keine Leitungen (Elektro, Gas, Wasser) beschädigen.  <p>Unsere Haftung beschränkt sich alleine auf unsere Produkte und kann daher nicht auf den Ein- und Ausbau ausgedehnt werden. Die Kosten für einen nachträglichen Aus- und Einbau eines Produkts und die damit verursachten Schäden sind kein Bestandteil der Garantie.</p>	<p>EN Please note carefully before installing!</p> <ul style="list-style-type: none"> • Before installing, check for correctness and damage and the accessories for completeness. • Do not under any circumstances install product with visible damage! • Take the great weight and/or the large dimensions into consideration when handling individual parts! • When drilling holes do not damage hidden pipes and wiring. <p>Our liability is limited to our products alone and therefore cannot be extended to installation and dismantling. Costs for subsequent dismantling and installation of a product and damage caused thereby are not part of the guarantee.</p> 	<p>FR A respecter impérativement avant le Montage!</p> <ul style="list-style-type: none"> • Avant le montage de vérifier qu'il s'agit du bon modèle, qu'elle n'est pas endommagée et que les accessoires sont complets. • En cas de dommages visibles, ne pas monter le produit! • Lors de la manutention, merci de prêter attention au poids parfois très élevé et/ ou aux dimensions de certaines pièces! • Faites attention en percant les trous de ne pas endommager les tuyauteries (cables électriques, canalisations de gaz, d'eau, etc). <p>Notre responsabilité se limite à nos produits et ne peut être étendue sur l'installation et le démontage. Les coûts générés lors d'un démontage après installation et d'une ré-installation d'un produit et les dommages qui en résultent ne pourront être pris en</p>	<p>NL Voor inbouw beslist in acht nemen!</p> <ul style="list-style-type: none"> • Bad voor het inbouwen op juistheid, beschadigingen en toebehoren op volledigheid controleren. • Bij zichtbare beschadiging product in geen geval inbouwen! • Let u bij het gebruik om het gedeeltelijk grote gewicht en/of de grote afmetingen van enkele onderdelen! • Bij het boren van gaten er op letten, dat U geen leidingen (elektro, gas of water) beschadigt! <p>Wanneer het bad betegeld wordt, beslist de inbouwmaten van de badkuip en van de doucheafscheiding in acht nemen. Onze aansprakelijkheid is beperkt tot onze producten en kan daarom niet op de in- en uitbouw uitgebreid worden. De kosten voor een latere uit- en inbouw van een product en de daaruit voortvloeiende schade zijn geen onderdeel van de garantie.</p>



DE ACHTUNG!
**Beim Hantieren
mit Glas Schutz-
kleidung tragen!**

Bitte untersuchen Sie nach dem Auspacken das Einscheiben-Sicherheitsglas (ESG) unverzüglich auf mögliche Transportschäden, wie abgesprungene Kanten oder Ecken. Wird ein Schaden festgestellt bitte umgehend Schadensmeldung machen und die Scheibe nicht einbauen, da dieser Fehler auch später zu einem Bruch führen kann! Alle Gläser werden vor dem Verpacken sorgfältig kontrolliert. Spätere Reklamationen, auch bei Bruch, können daher nicht anerkannt werden.



EN ATTENTION!
**Wear protective
clothing when
handling glass!**

Please examine the single-pane safety glass for possible transport damage such as chipped edges or corners immediately after unpacking. If damage is detected do not install the pane because a defect can lead to breakage later! Please make a damage report without delay! All glass panes are controlled with utmost care before packing. Therefore later complaints cannot be acknowledged, even in case of breakage.

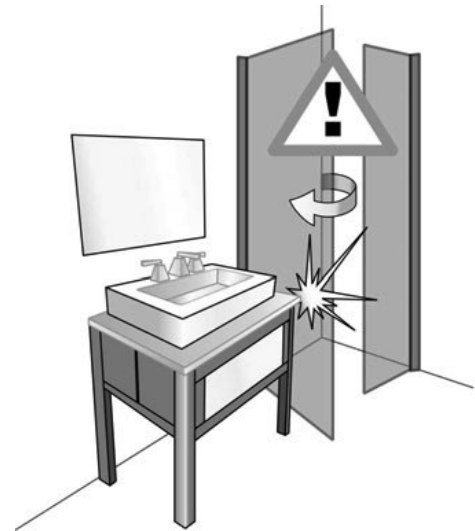

FR ATTENTION!
**Portez des vête-
ments protecteurs
en manipulant du
verre.**

Merci de vérifier immédiatement le verre de sécurité monofeuille au déballage sur d'éventuels dommages survenus au transport, tels que chants et angles écaillés. Si toutefois un défaut a été constaté, merci d'en faire la déclaration au plus vite et ne pas monter la vitre, car ce défaut peut être, par la suite, à l'origine d'une casse! Tous les verres sont contrôlés minutieusement avant le conditionnement. Pour cette raison, aucune réclamation ultérieure, même en cas de casse, ne pourra être prise en compte.

NL ATTENTIE!
**Bij het hanteren
van glas be-
schermde kle-
ding dragen!**

Na het uitpakken het enkel veiligheidsglas (ESG) onmiddellijk op mogelijke transportbeschadigingen, zoals afgesprongen kanten of hoeken, controleren. Wordt een beschadiging vastgesteld, dan mag het glas niet worden ingebouwd, omdat deze schade ook later tot een breuk kan leiden! Bij een vastgestelde schade, meldt dit onmiddellijk! Al het glas wordt voor het verpakken zorgvuldig gecontroleerd. Latere reclames, ook bij breuk, kunnen daarom niet geaccepteerd worden.











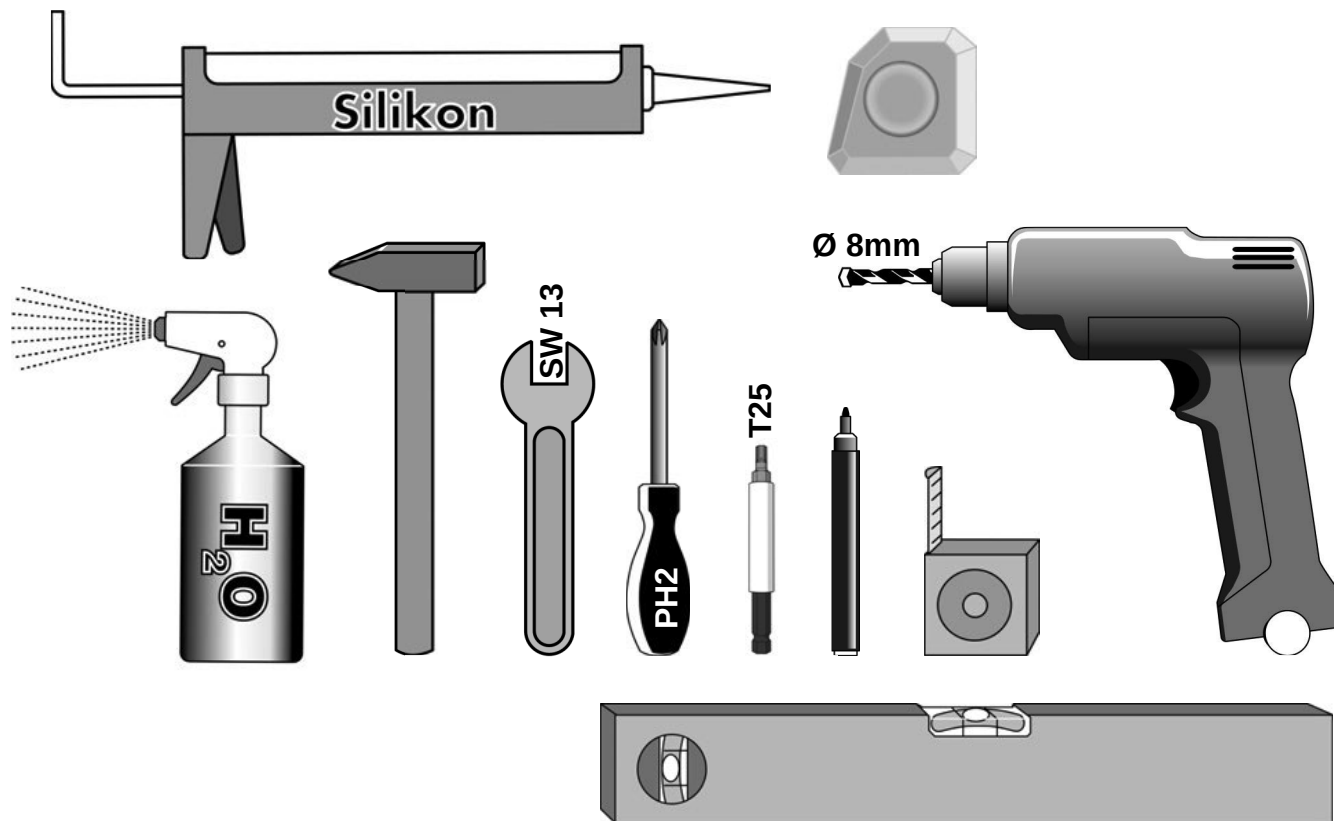



BENÖTIGTES
WERKZEUG

NECESSARY
TOOLS

OUTILLAGE
NECESSAIRE

BENODIGD
GEREEDSCHAP

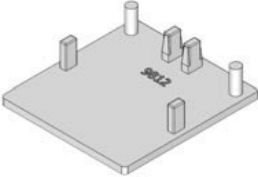
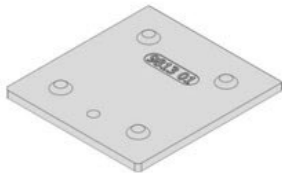

MONTAGESET	ASSEMBLY KIT	SET DE MONTAGE	MONTAGESET
<p>4x \varnothing 8x50 mm Mat. Nr.: 24409</p> 	<p>4x 4,8x60 mm Mat. Nr.: 24466</p> 	<p>4x 125A-5,3-A2 Mat. Nr.: 2494</p> 	<p>1x SW 3 mm Mat. Nr.: 18993</p> 
<p>1x SW 4 mm Mat. Nr.: 18750</p> 	<p>2x DIN913-M6x4-A2 Mat. Nr.: 24243</p> 	<p>10x ISO7380-M5x10-A2</p> 	<p>2x Mat. Nr.: 709811</p> 
<p>2x Mat. Nr.: 709821</p> 	<p>2x Mat. Nr.: 709812</p> 	<p>4x Mat. Nr.: 709813</p> 	<p>8x Mat. Nr.: 10994</p> 
<p>2x Mat. Nr.: 704520</p> 			

MONTAGEVARIANTEN

ASSEMBLY VARIATIONS

VARIANTES
DE MONTAGE

MONTAGEVARIANTEN

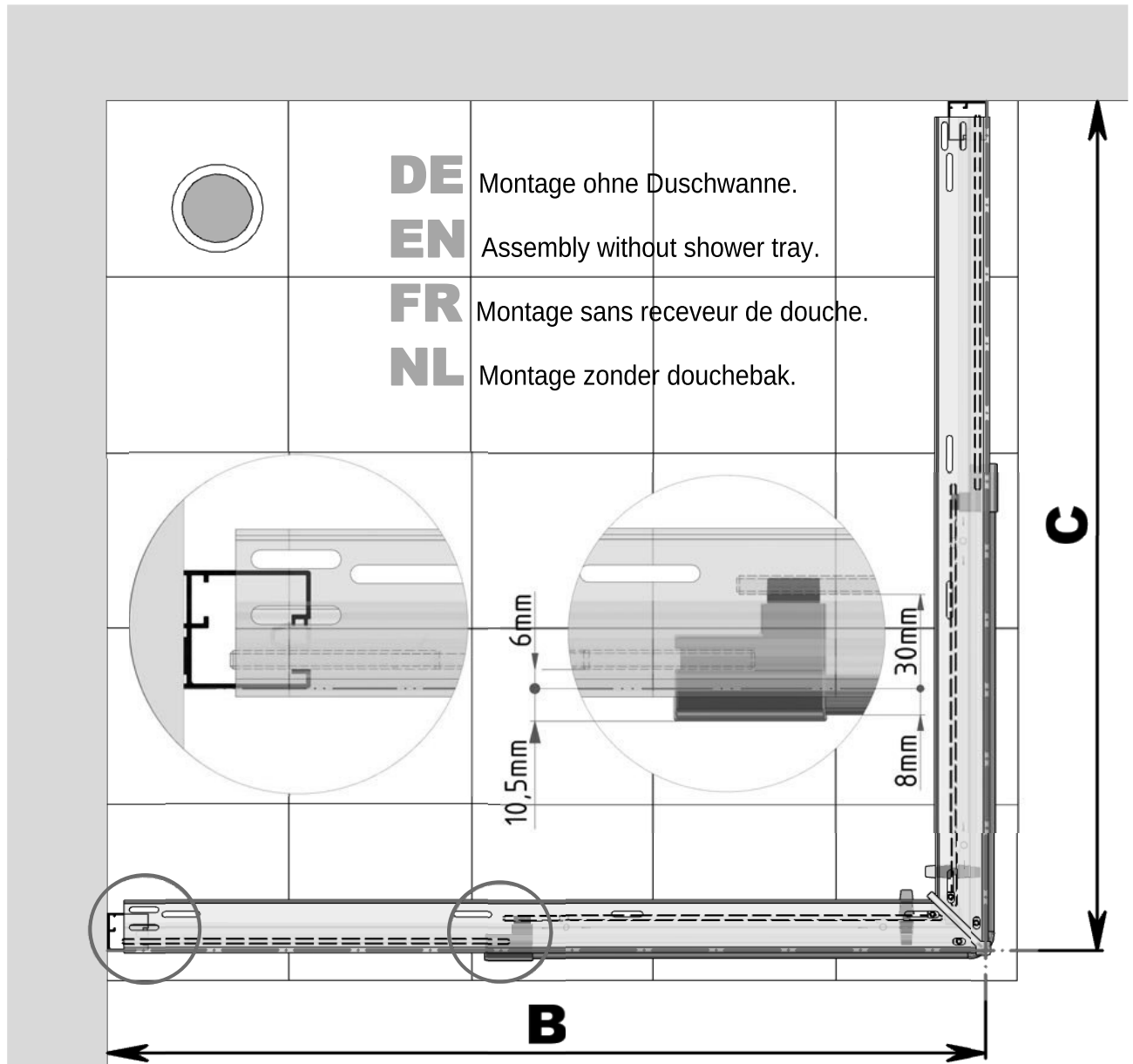

VERSTELLBEREICH

ADJUSTMENT RANGE

PLAGE
D'AJUSTEMENT

VERSTELBAARHEID

Auftrag Nr.:

Serie

B

C

Sondergrößen • special sizes • mesures spéciales • speciale maten

800

769 ± 10 mm

769 ± 10 mm

B= **mm** **C=** **mm**

900

869 ± 10 mm

869 ± 10 mm

1000

969 ± 10 mm

969 ± 10 mm

1200

1169 ± 10 mm

1169 ± 10 mm

MONTAGEVARIANTEN

ASSEMBLY VARIATIONS

VARIANTES
DE MONTAGE

MONTAGEVARIANTEN

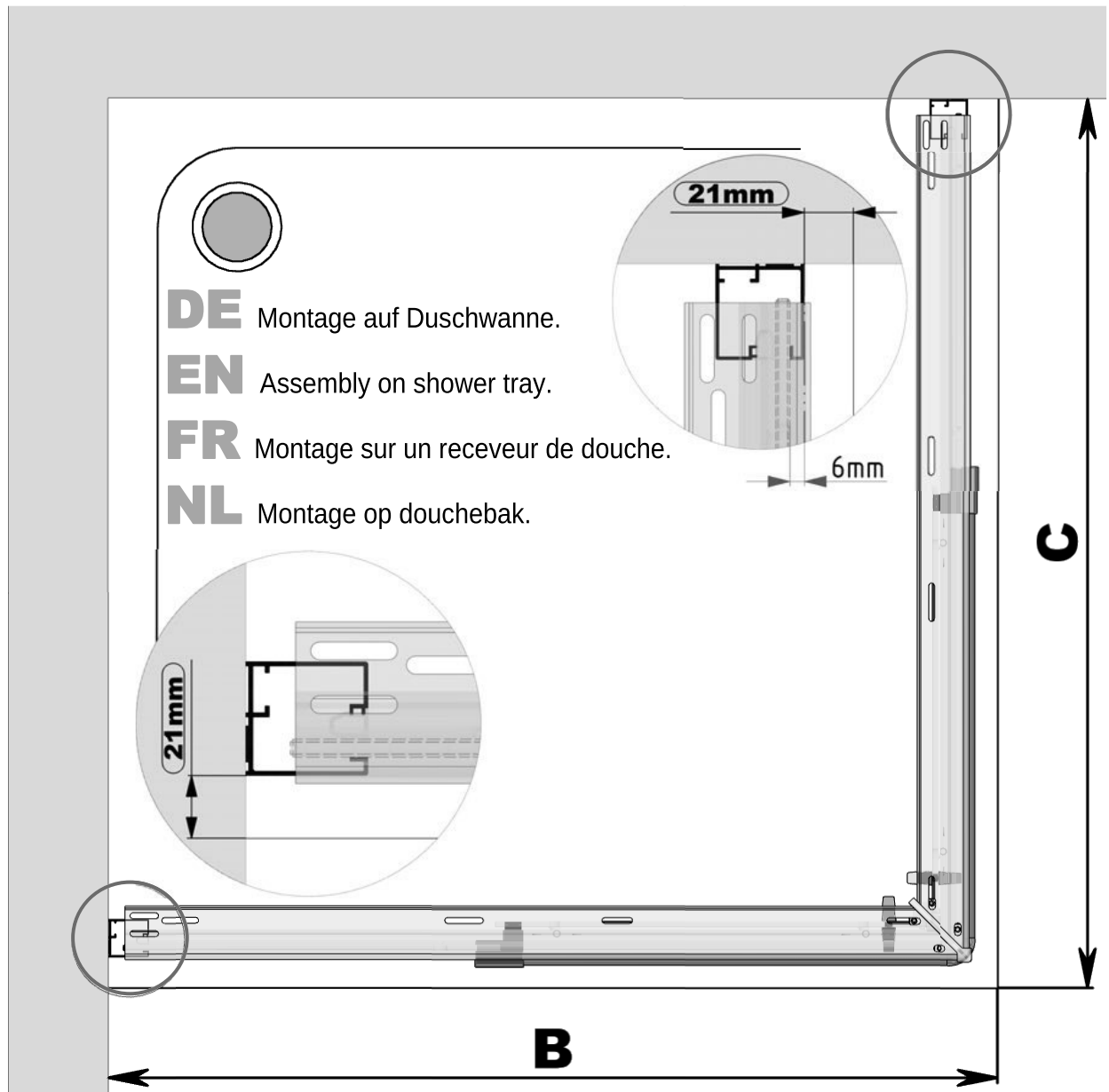

WANNEN-
EINBAUMASS

TRAY INSTALLATION
MEASUREMENT

MESURES POUR MONTAGE
SUR RECEVUR

DOUCHEBAK-
INBOUWMAAT

Serie	B	C
800	780 - 800 mm	780 - 800 mm
900	880 - 900 mm	880 - 900 mm
1000	980 - 1000 mm	980 - 1000 mm
1200	1180 - 1200 mm	1180 - 1200 mm

1

DE ACHTUNG! Eine einwandfreie Montage ist nur möglich, wenn der Boden **waagrecht** und die Wände **senkrecht** sind. Bei Bedarf beiliegende **Unterlagsplättchen** verwenden!

EN ATTENTION! Correct installation is only possible, if the floor is horizontal and the walls are vertical. If needed use the enclosed spacing plates!

FR ATTENTION! Un montage impeccable n'est possible que si le sol est parfaitement plan et le murs droits. En cas de besoin utiliser les cales fournies!

NL LET OP! Een perfecte montage is alleen mogelijk, als de bodem horizontaal en de wanden verticaal t.o.v. elkaar staan. Indien nodig, bijgevoegde onderlegplaatjes gebruiken!

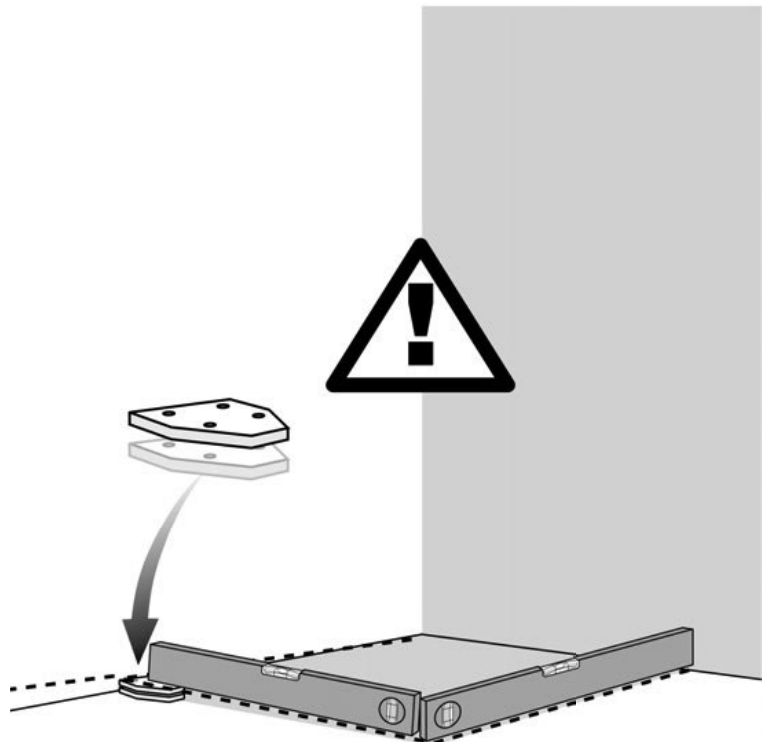

2

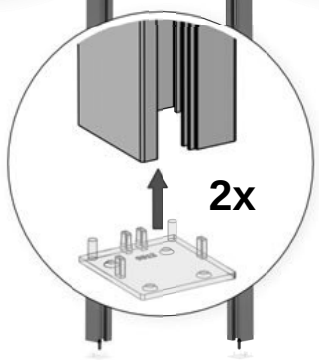
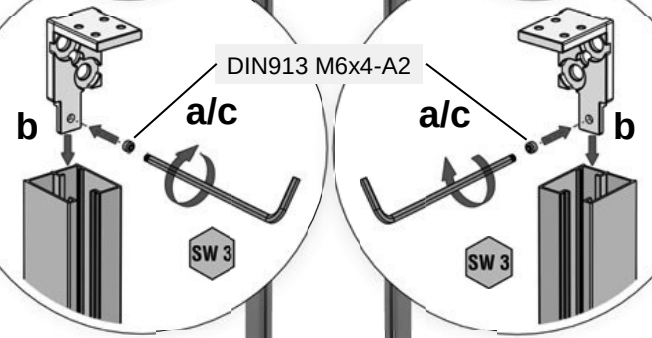
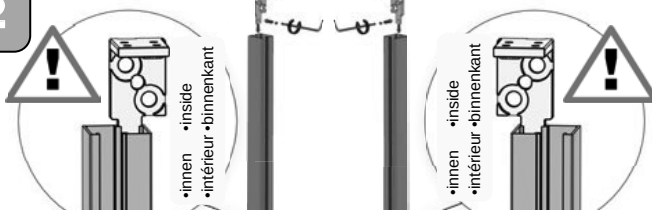

3

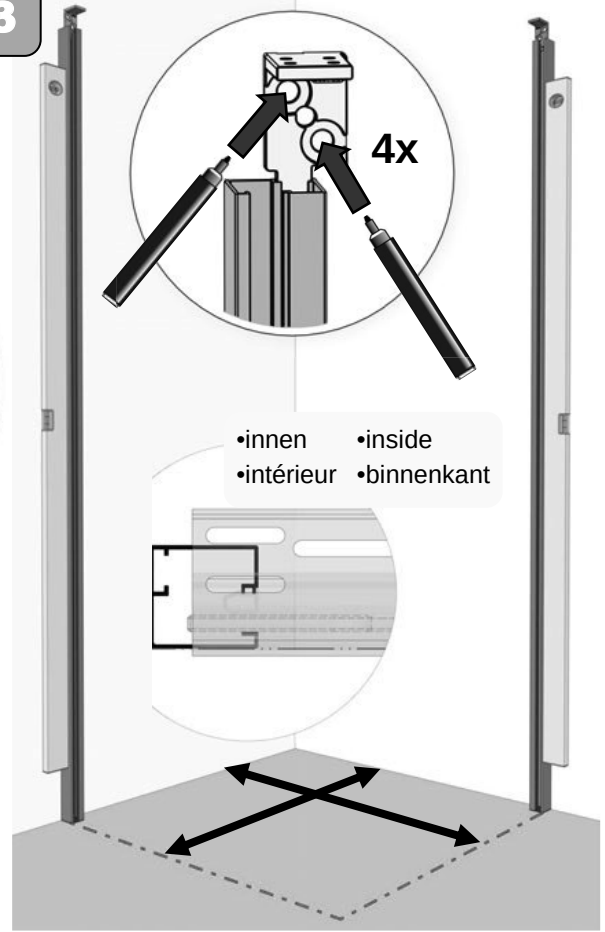

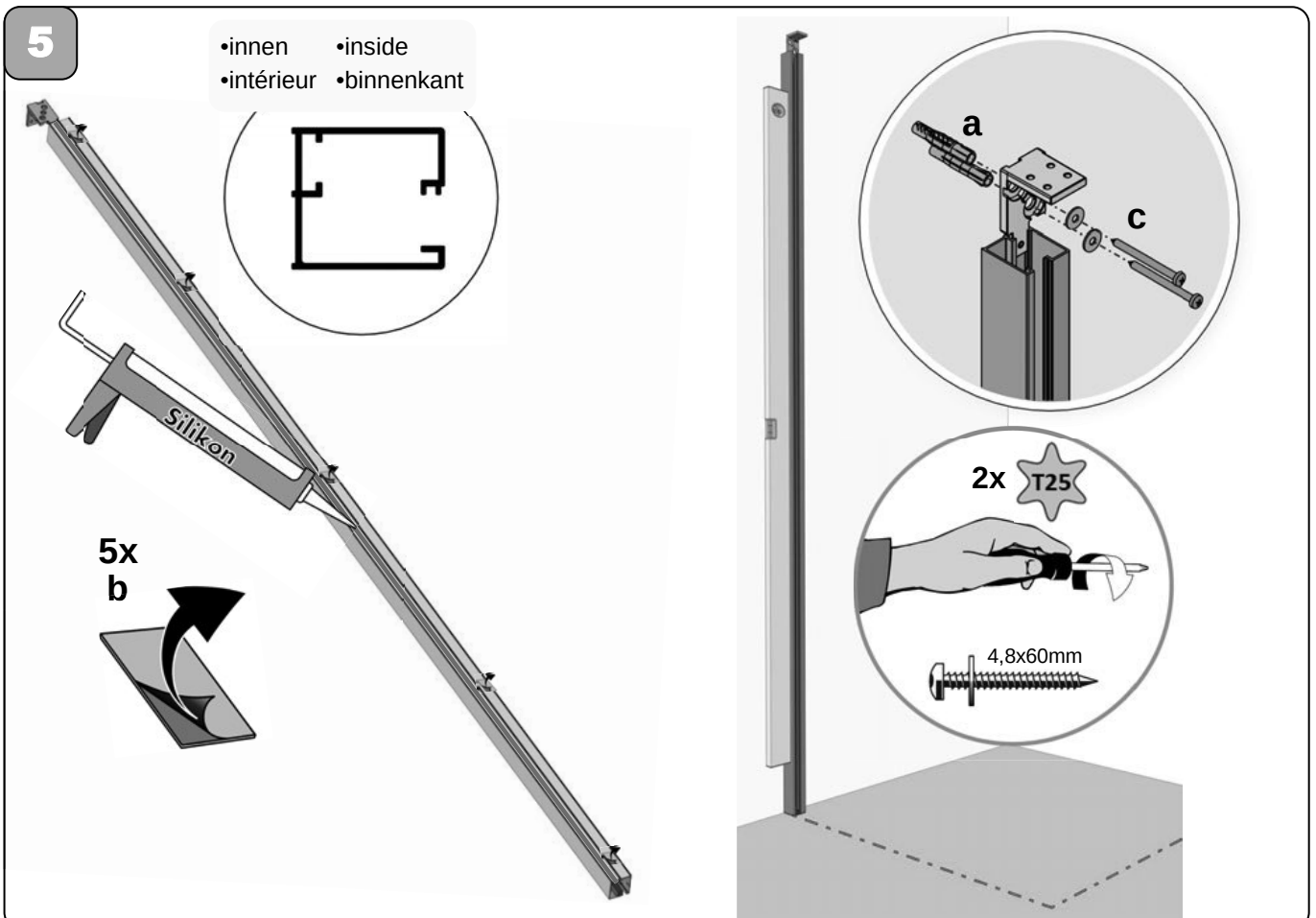
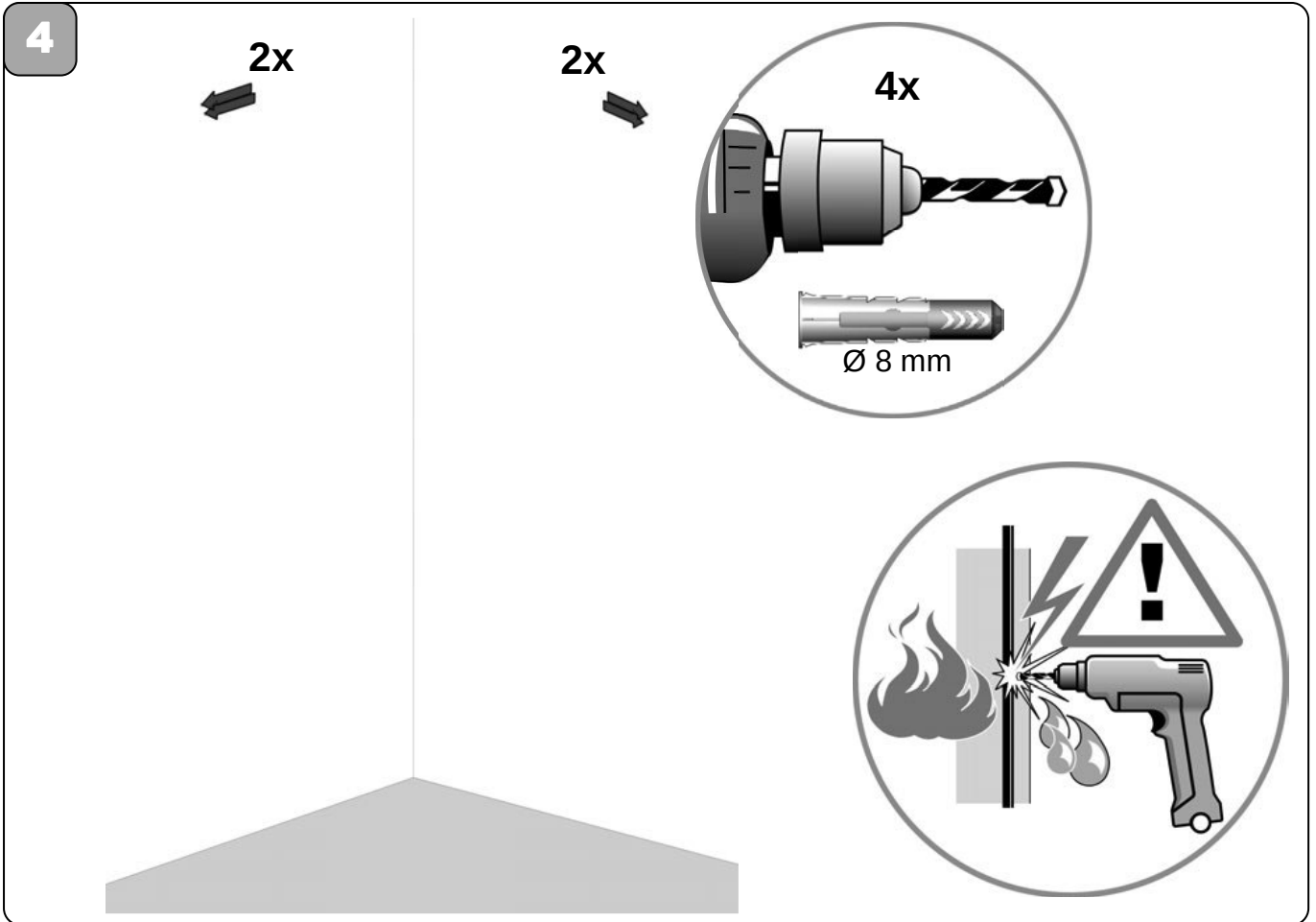

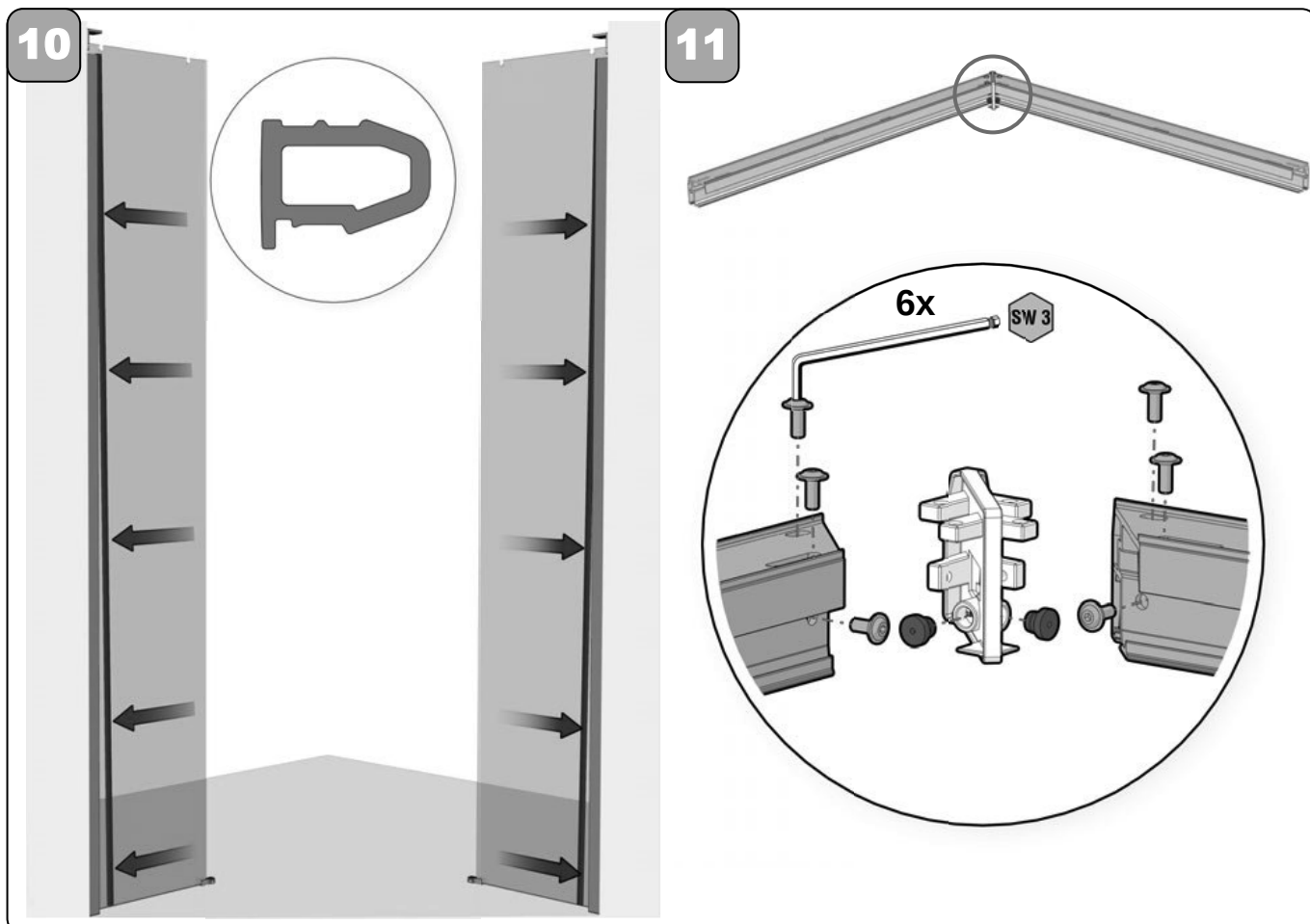
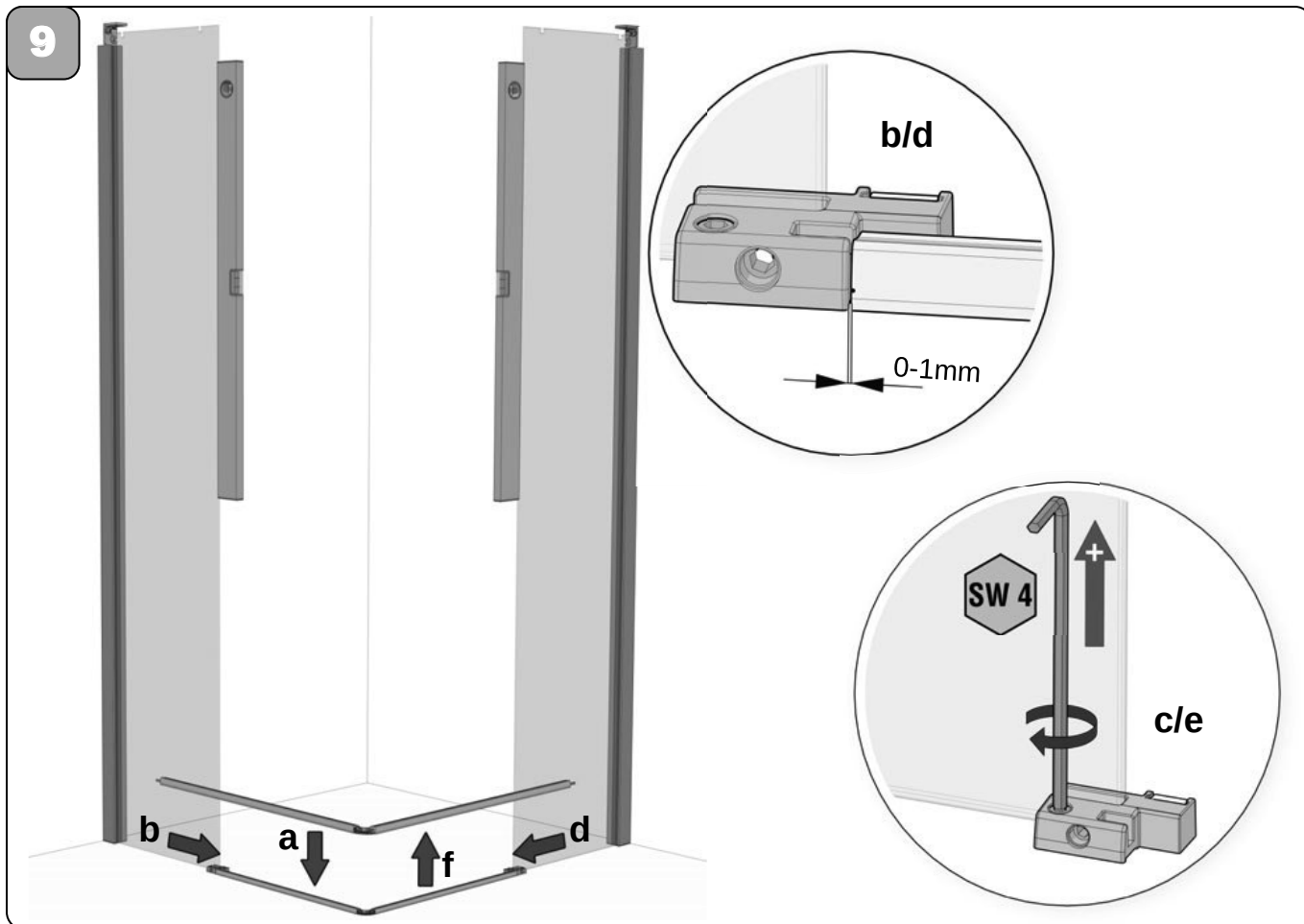

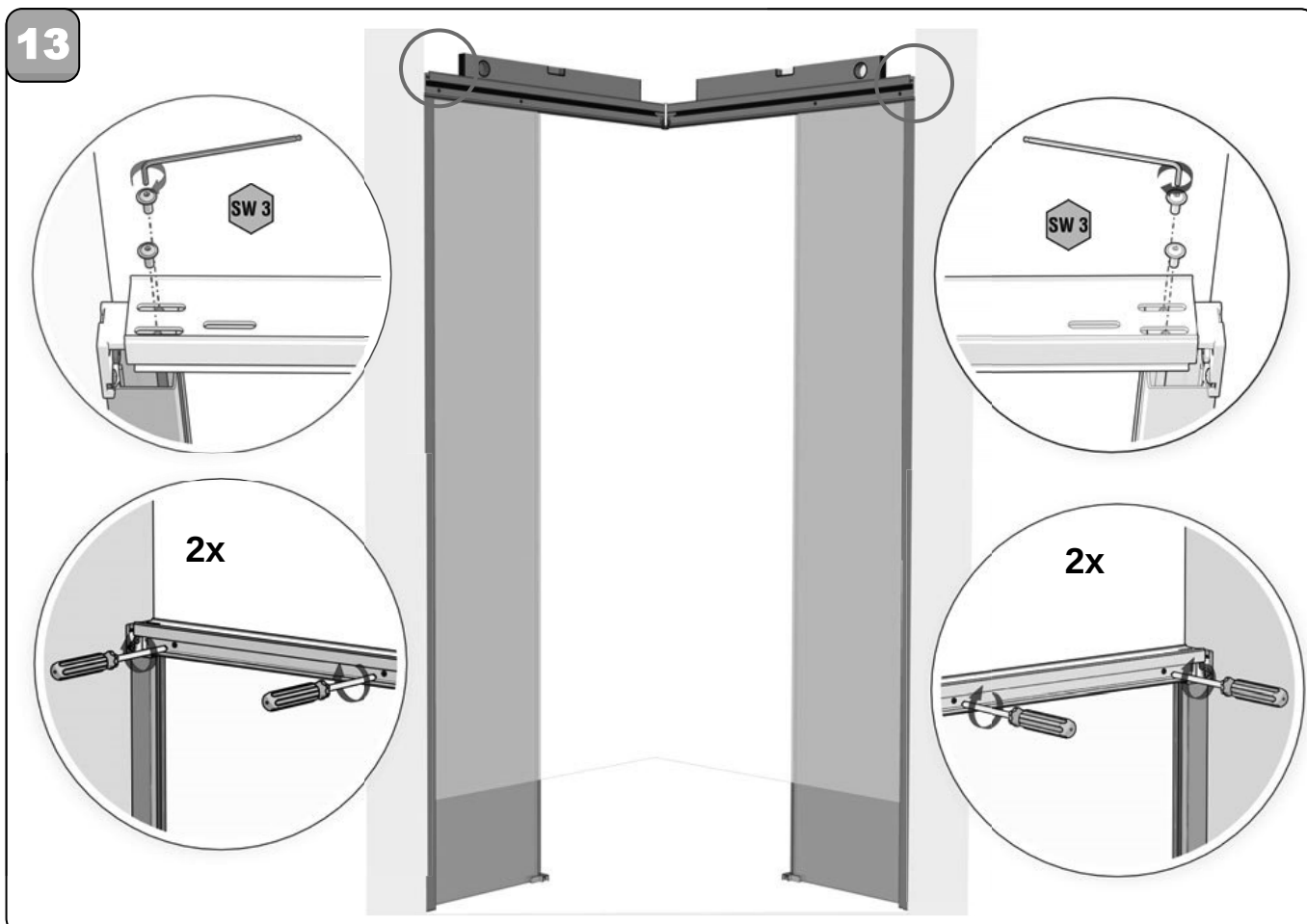
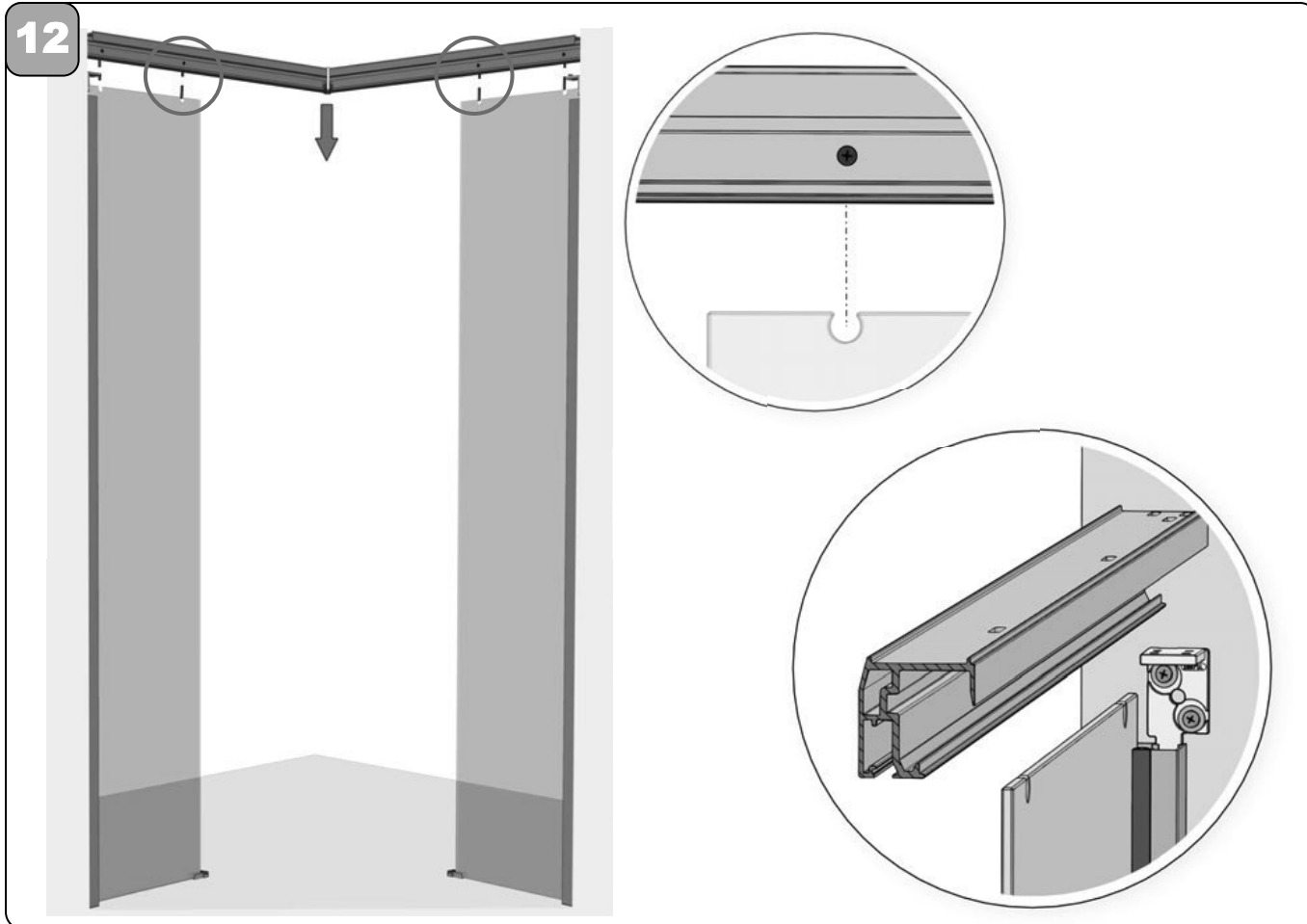

14

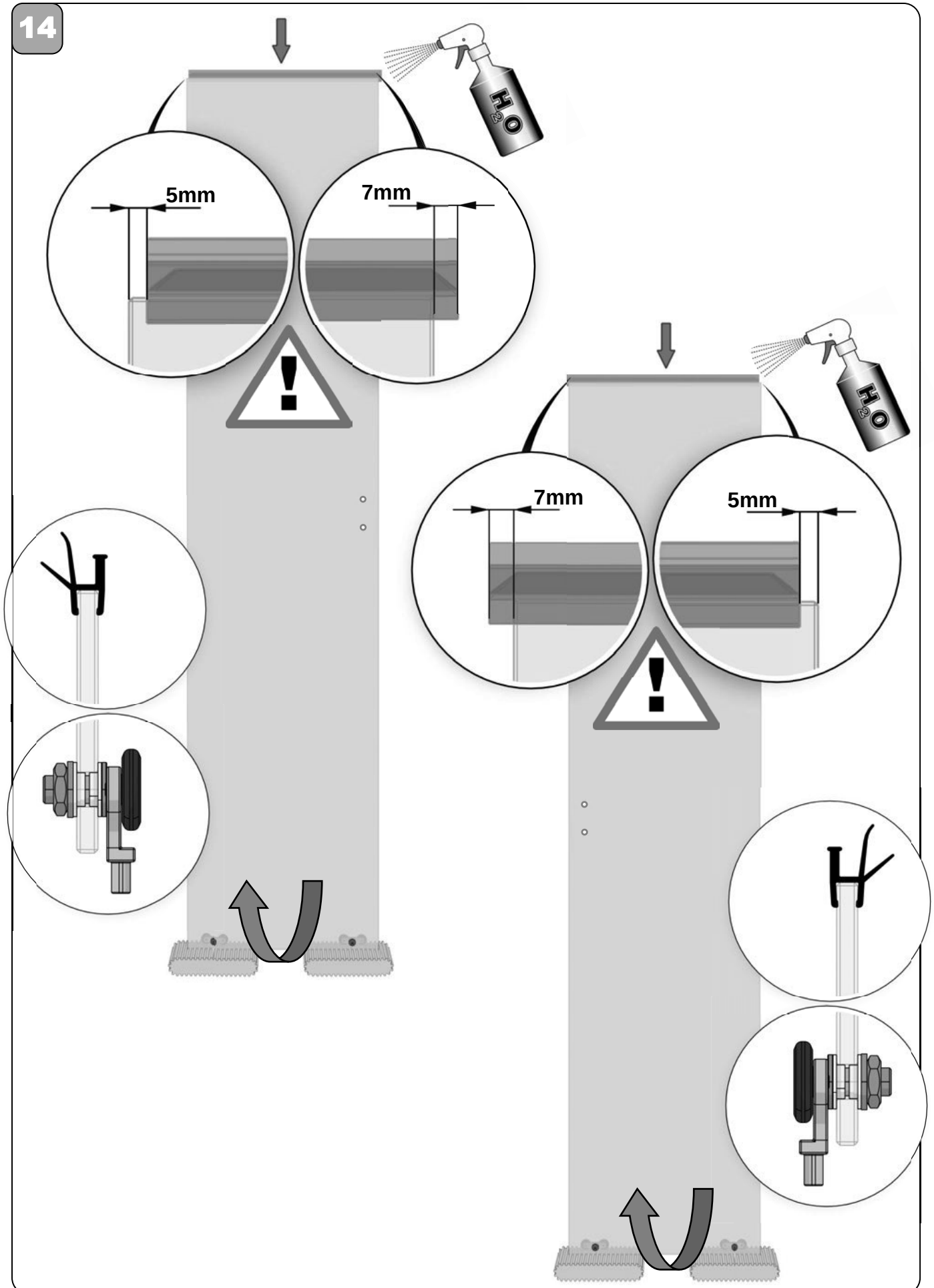

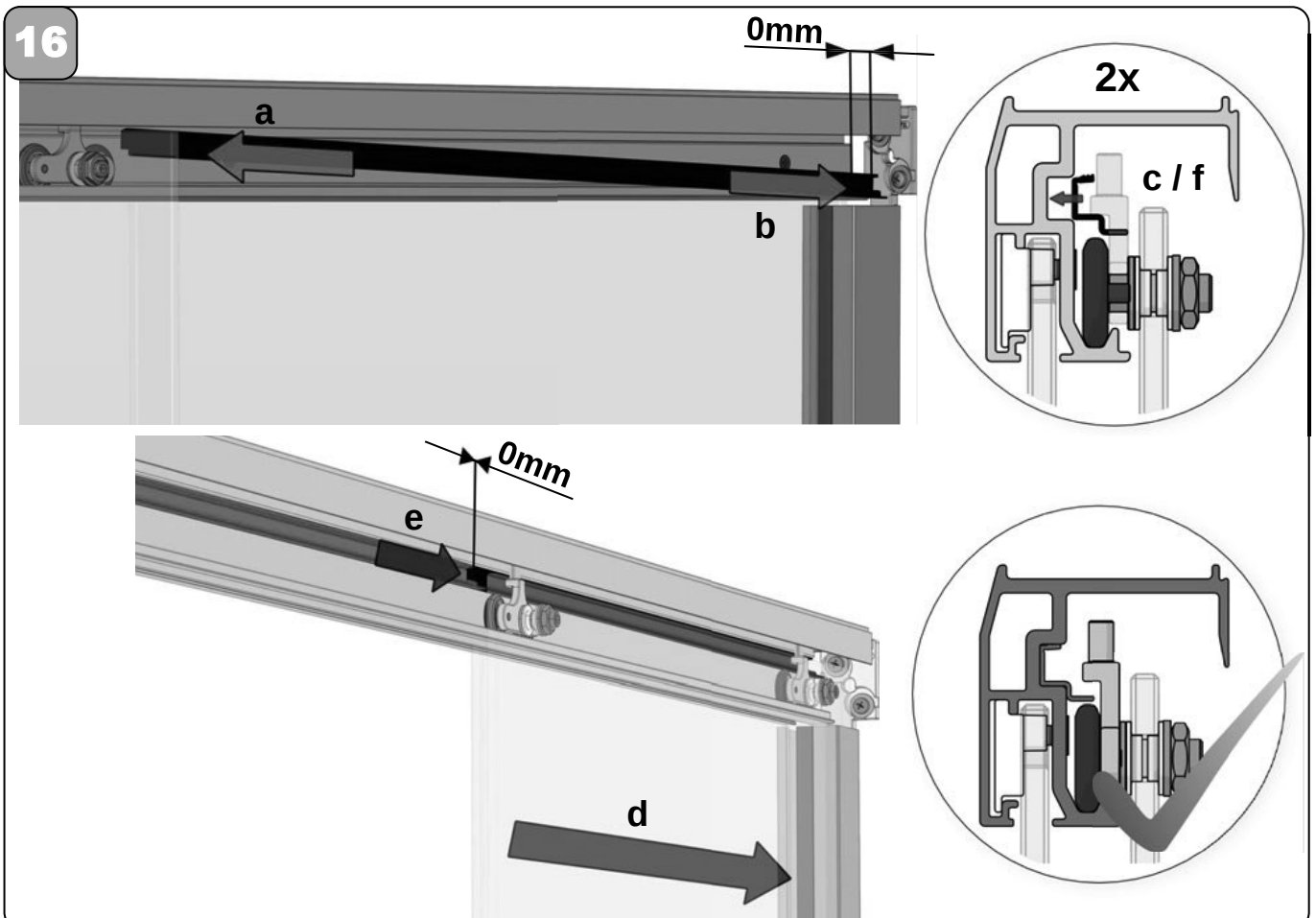
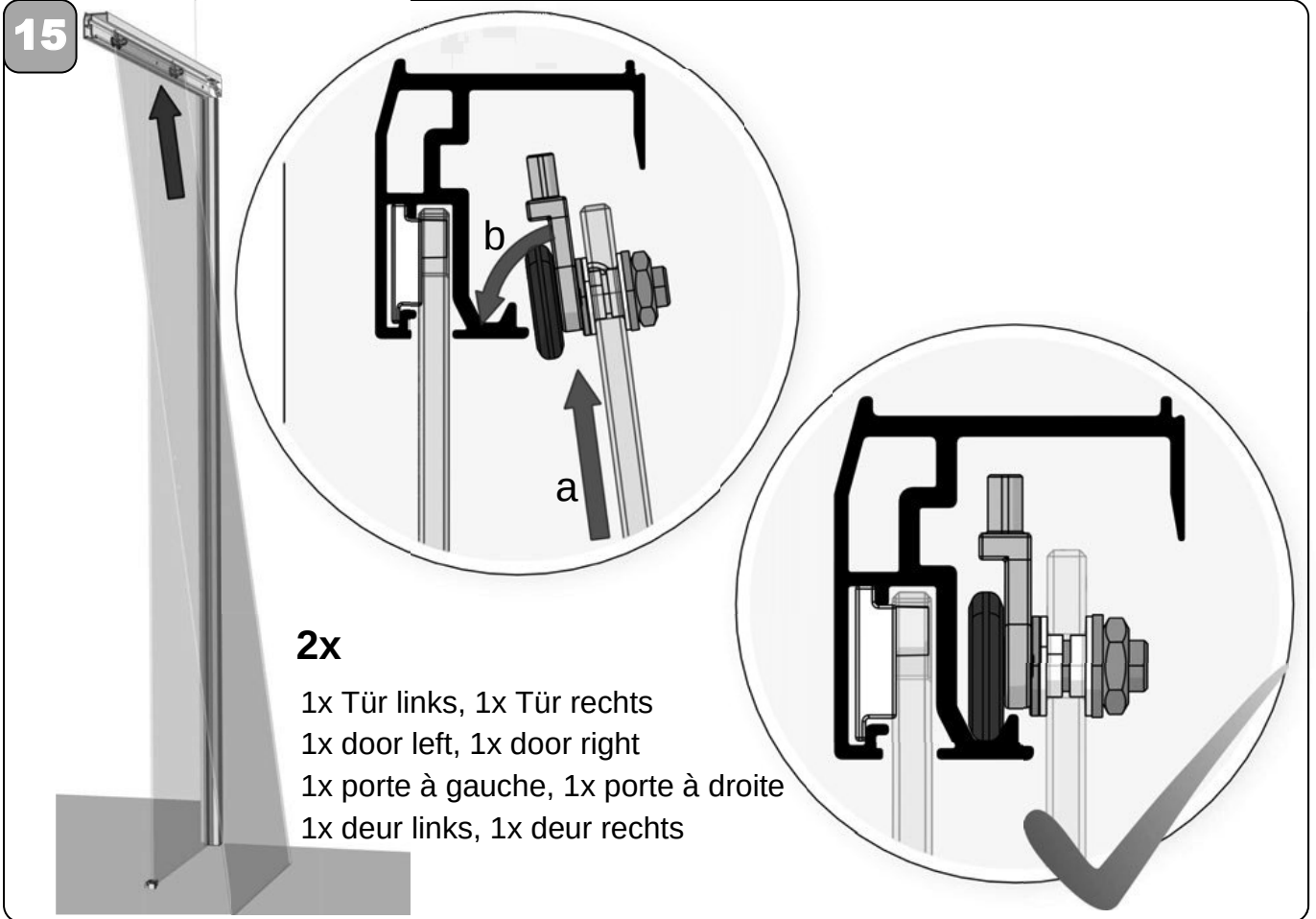

17

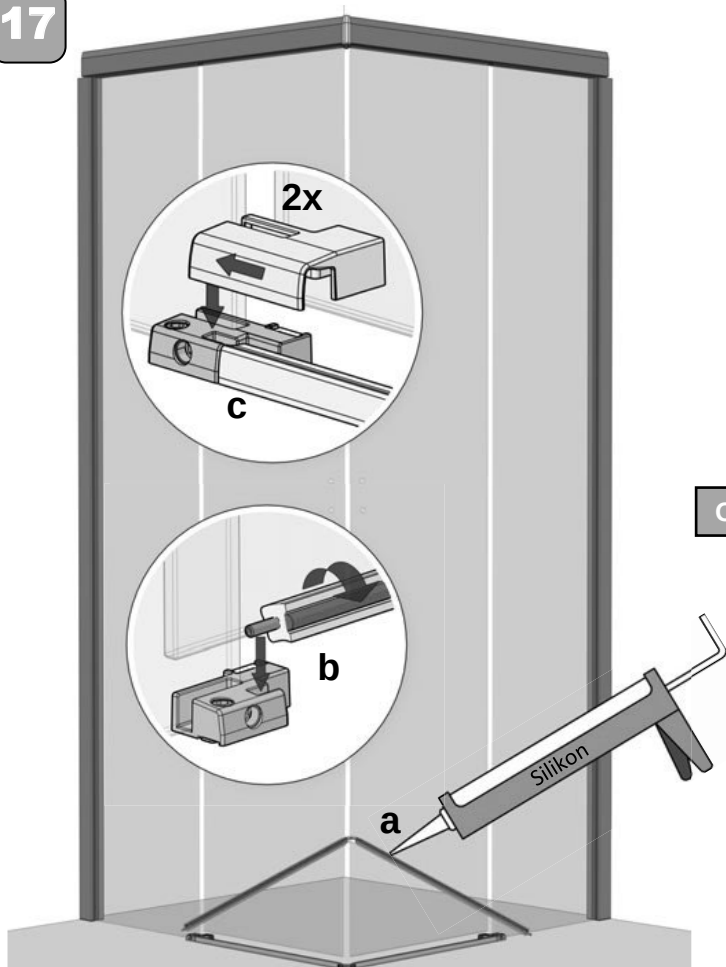

•innen •inside
•intérieur •binnenkant

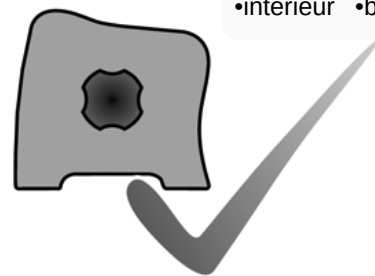

OPTIONAL	OPTIONAL	EN OPTION	OPTIONEEL
----------	----------	-----------	-----------

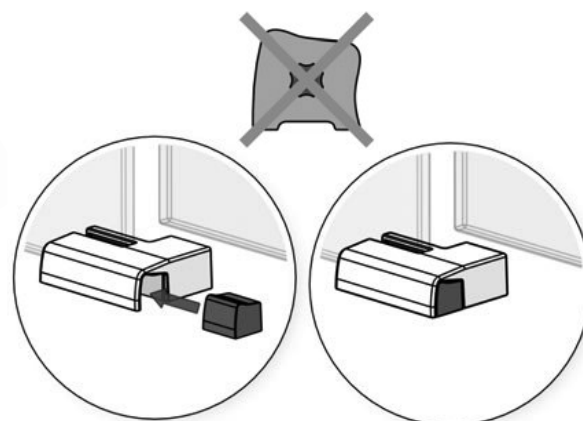

DE Der Hersteller weist an dieser Stelle ausdrücklich darauf hin, dass die Montage der im Lieferumfang enthaltenen Schwalleiste zur Erreichung der Dichtheitsanforderungen nach Norm (DIN 14428) erforderlich ist. Wird auf die Schwalleiste verzichtet, übernimmt der Hersteller keinerlei Haftung für daraus resultierende Schäden. Eine spätere Montage der Schwalleiste ist ohne bauliche Veränderungen an der Duschtrennung möglich. Für diesen Fall bitte das nicht verwendete Montagematerial dem Endkunden zur Aufbewahrung übergeben.

EN At this stage the manufacturer makes a point of expressly informing you that mounting of the solid sealing strip delivered is necessary to achieve the degree of sealing required under the standard DIN 14428. If you dispense with the sealing strip, the manufacturer accepts no liability whatsoever for resulting damages. It is possible to mount the surge strip at a later date without any changes to the shower side wall. In this case please hand over the unused fixation materials to the customer for storage.

FR A cet endroit, le fabricant indique expressément que le montage de la baguette de refoulement est indispensable pour obtenir l'étanchéité requise par la Norme (DIN 14428). Si toutefois cette baguette de refoulement n'est pas installée, le fabricant ne peut, en aucun cas, être tenu pour responsable des dégâts qui en résulteraient. Le montage de la baguette de refoulement est toujours possible sans modification de la cabine de douche. Dans ce cas merci de remettre le matériel de montage non utilisé au client final pour le conserver.

NL De producent maakt u er op dit punt op attent, dat de montage van de in de levering opgenomen spatrand nodig is om aan de dichtheidseisen naar norm DIN 14428 te voldoen. Wanneer u afziet van montage van de spatrand, is de producent niet aansprakelijk voor eventuele daaruit vloeiende schade. Een latere montage van de spatrand is mogelijk zonder dat een bouwkundige verandering van de doucheafdeling nodig is. In dit geval het niet het gebruikte montagemateriaal aan de eindklant geven om te bewaren.

18

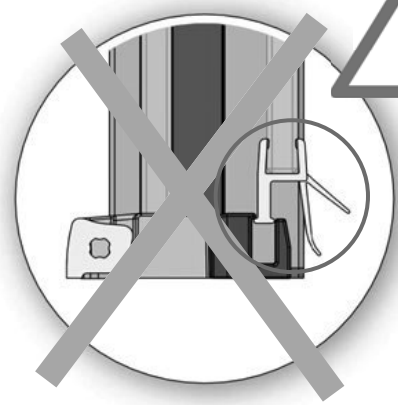
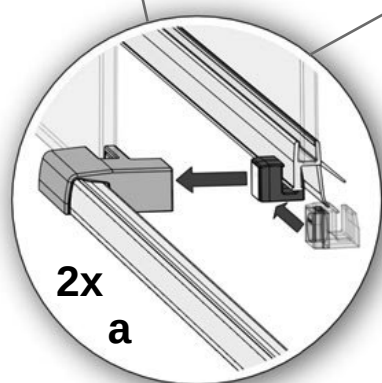
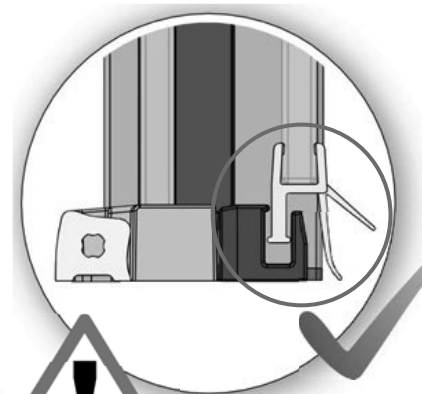
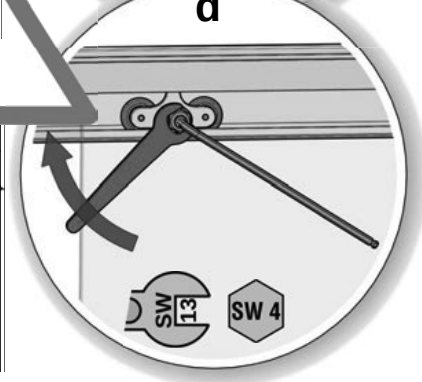
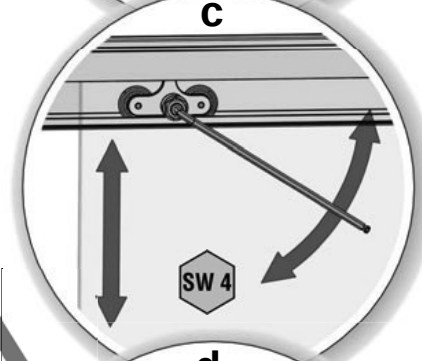
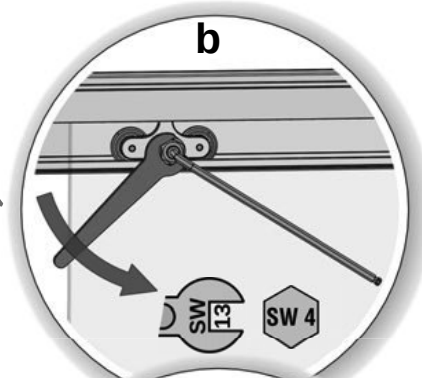
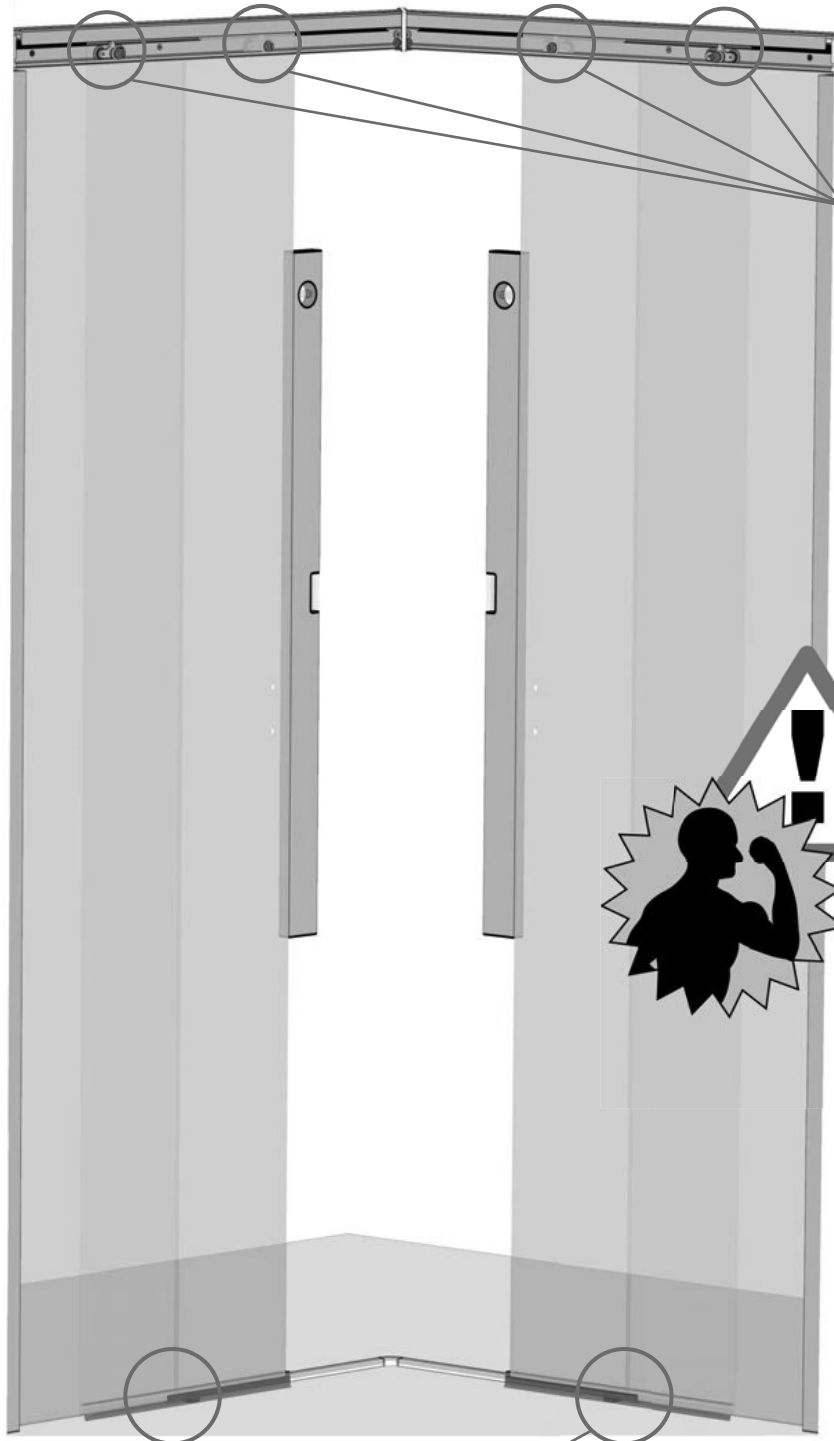

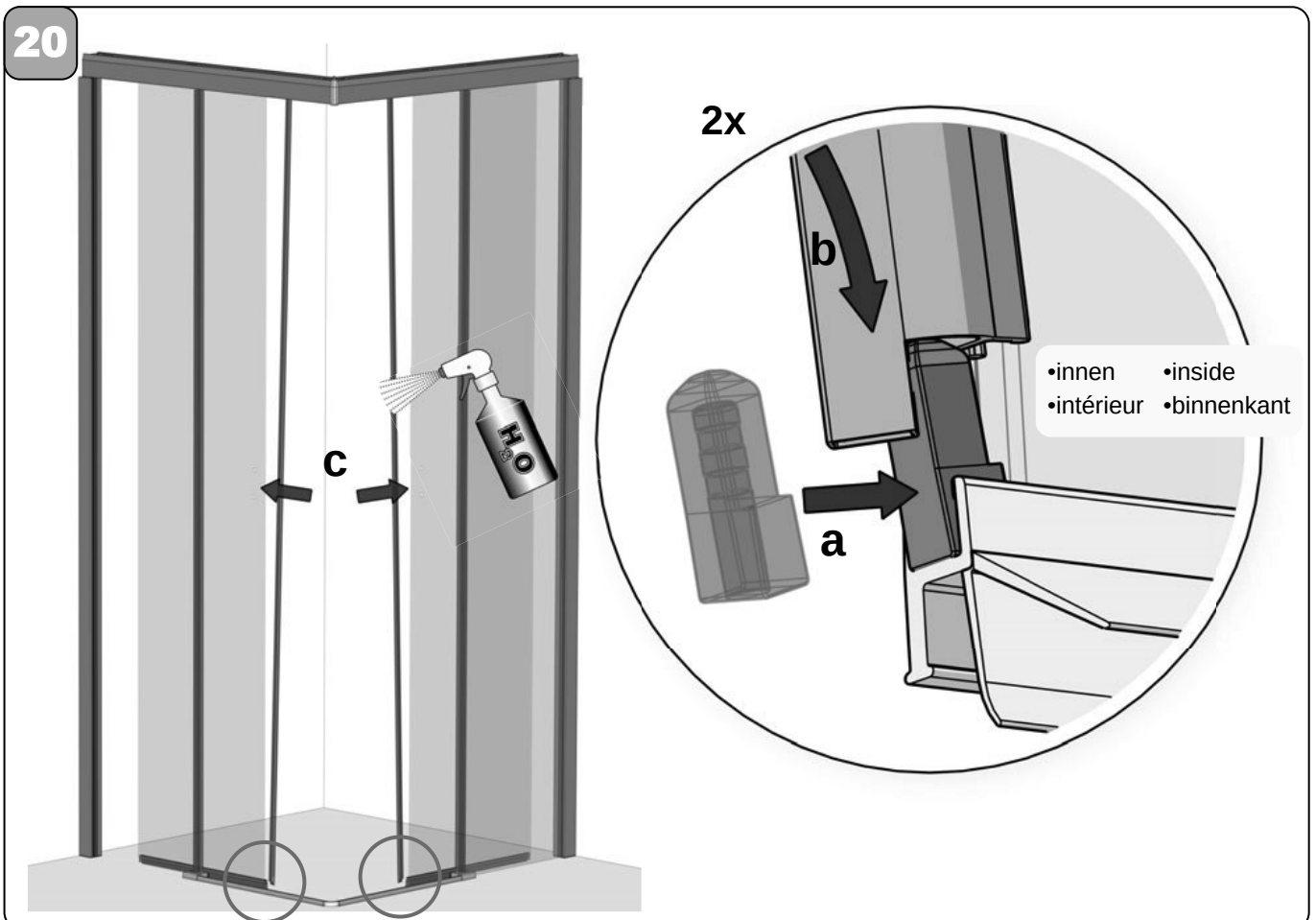
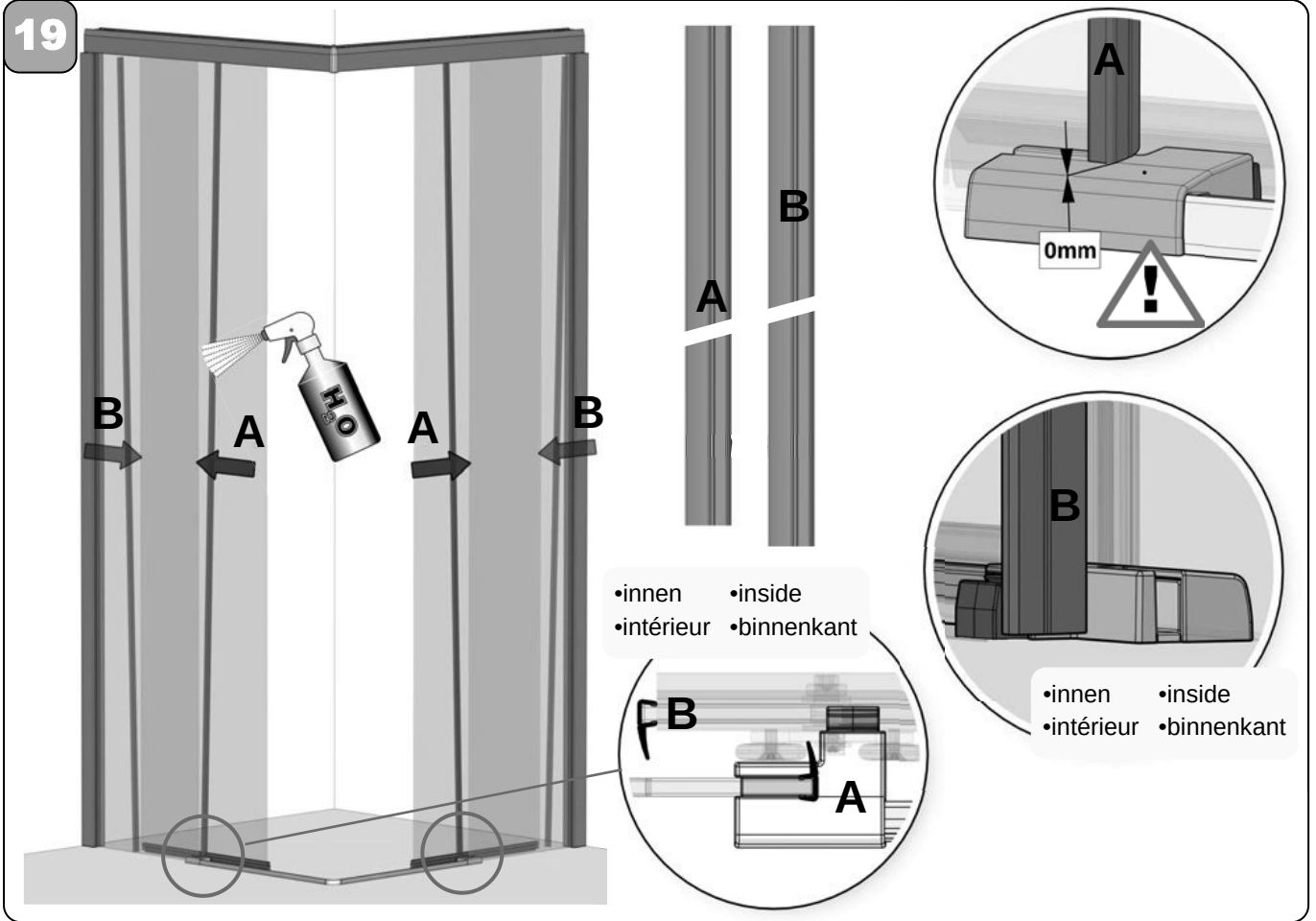

21

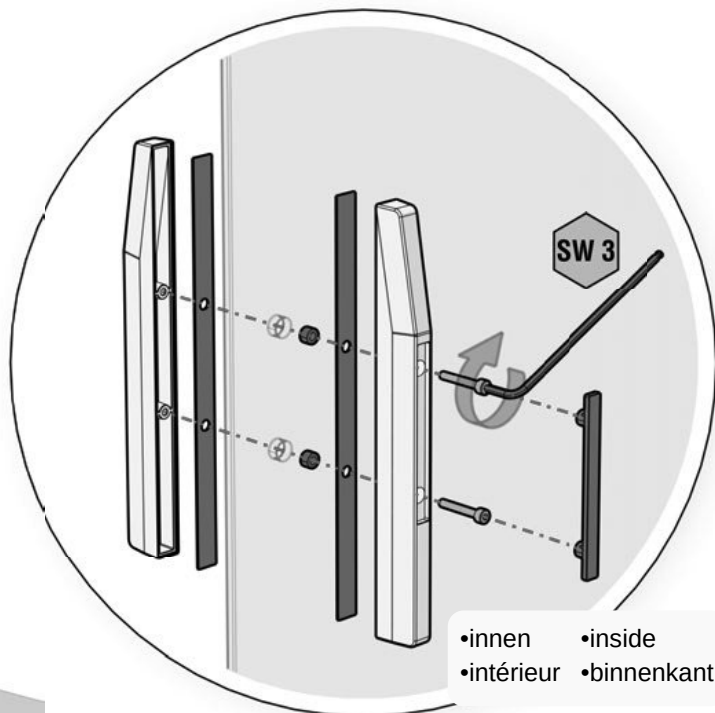
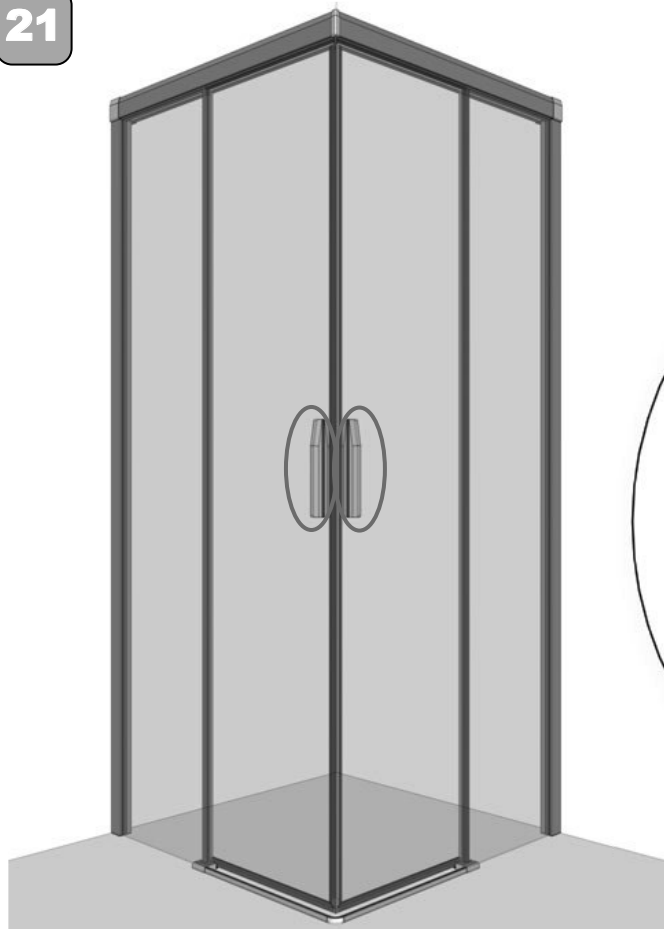

22

OPTIONAL

OPTIONAL

EN OPTION

OPTIONEEL

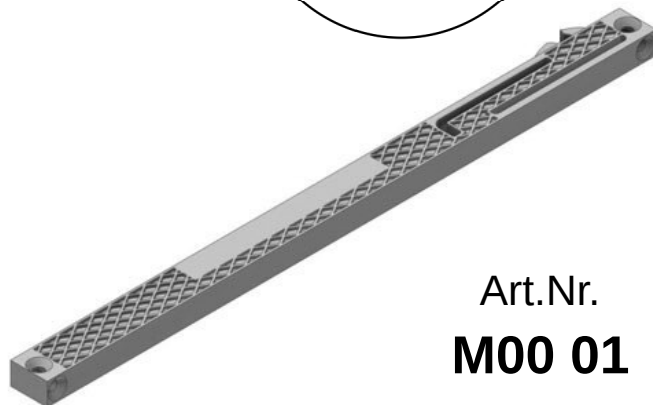
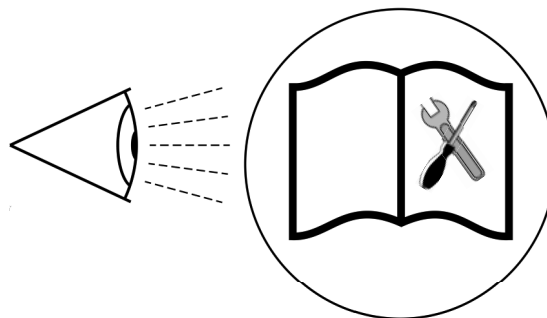
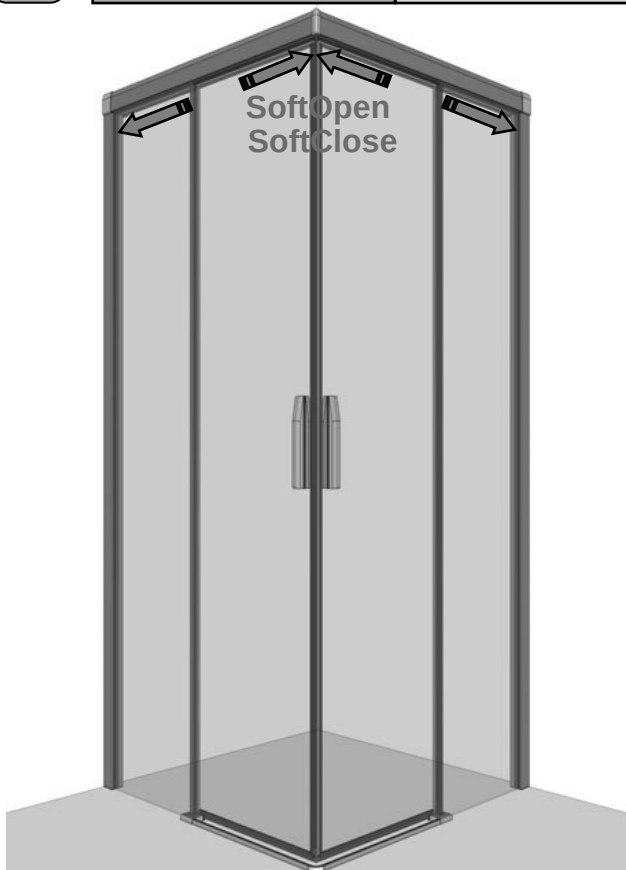

Art.Nr.
M00 01

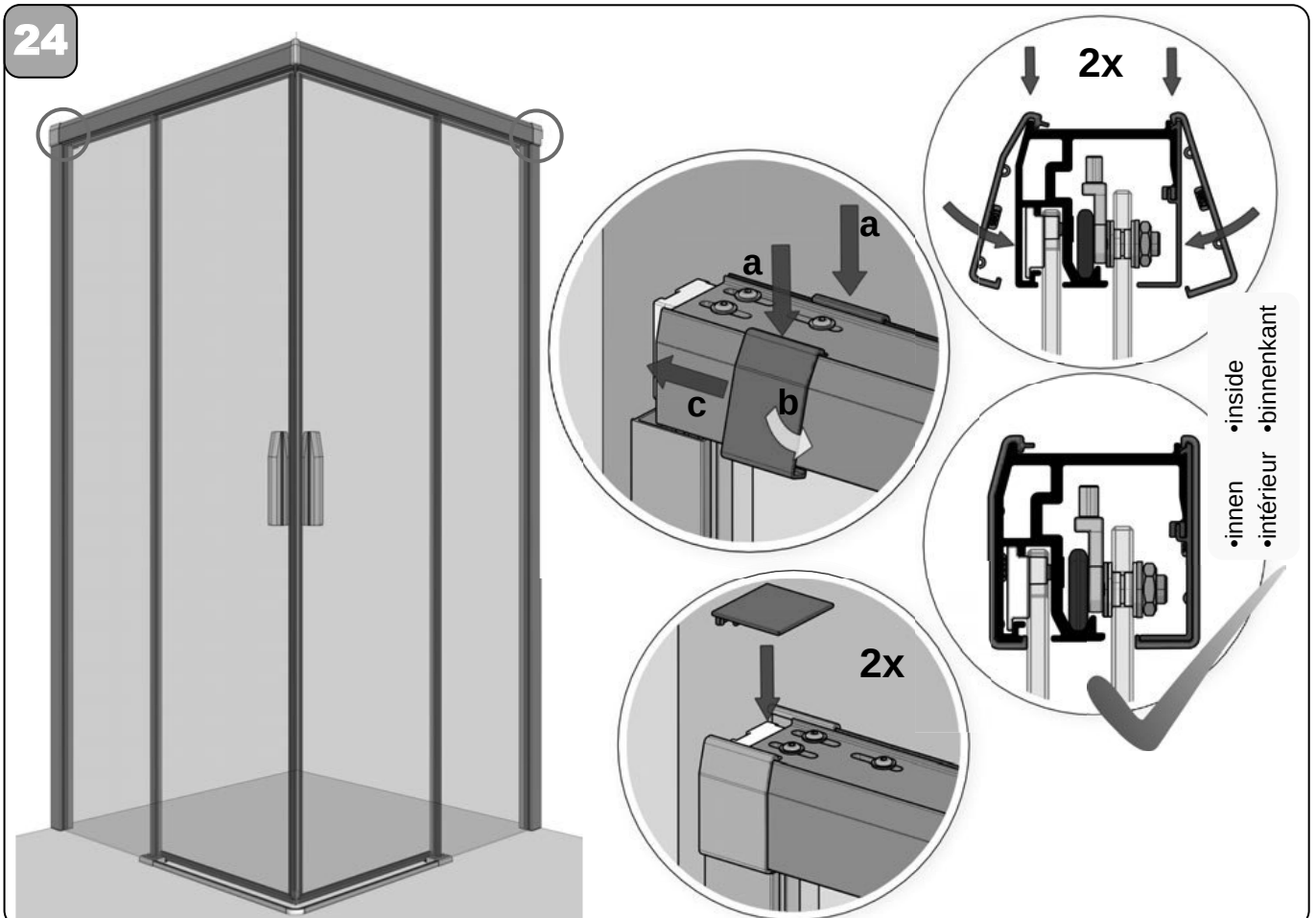
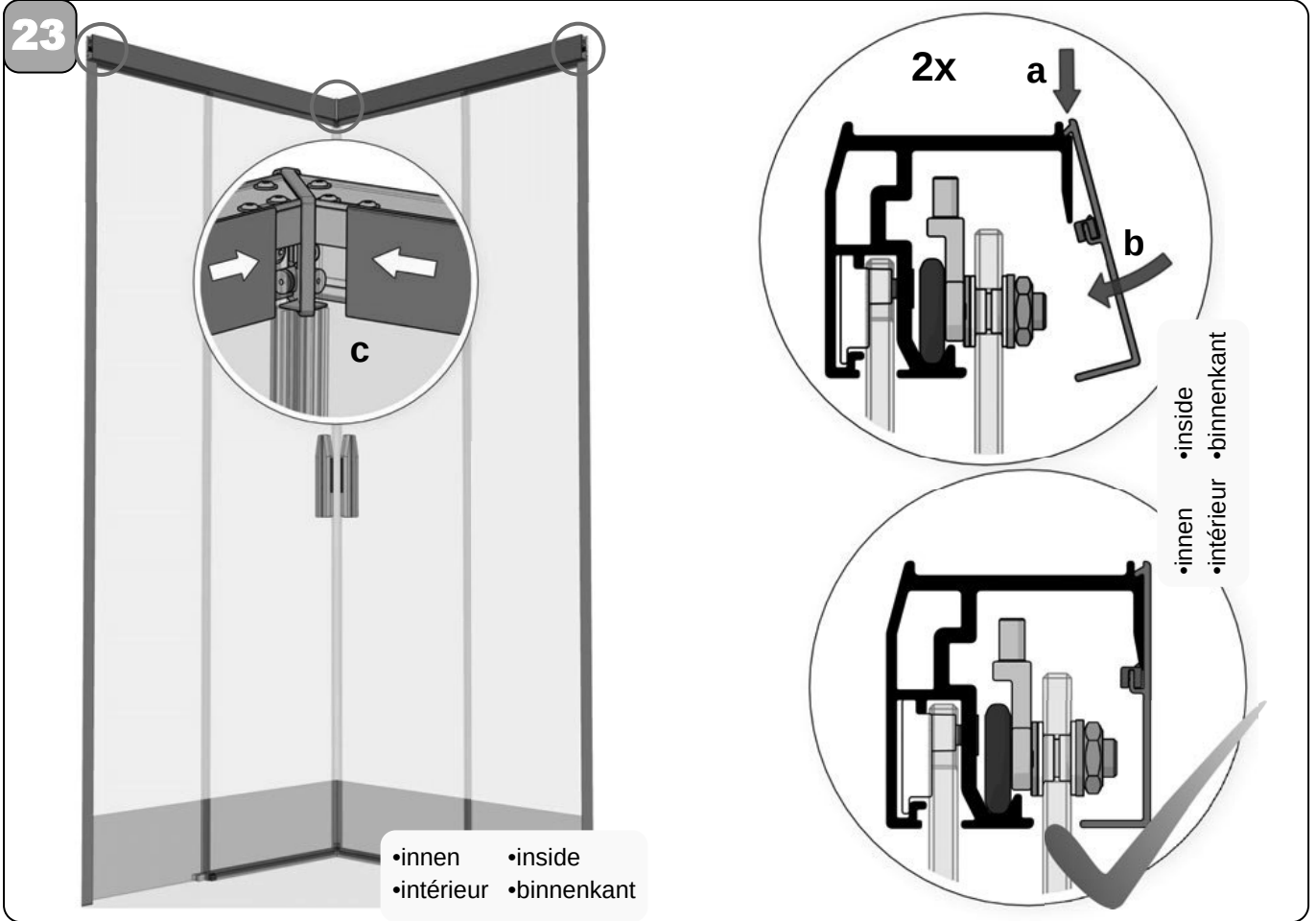

25

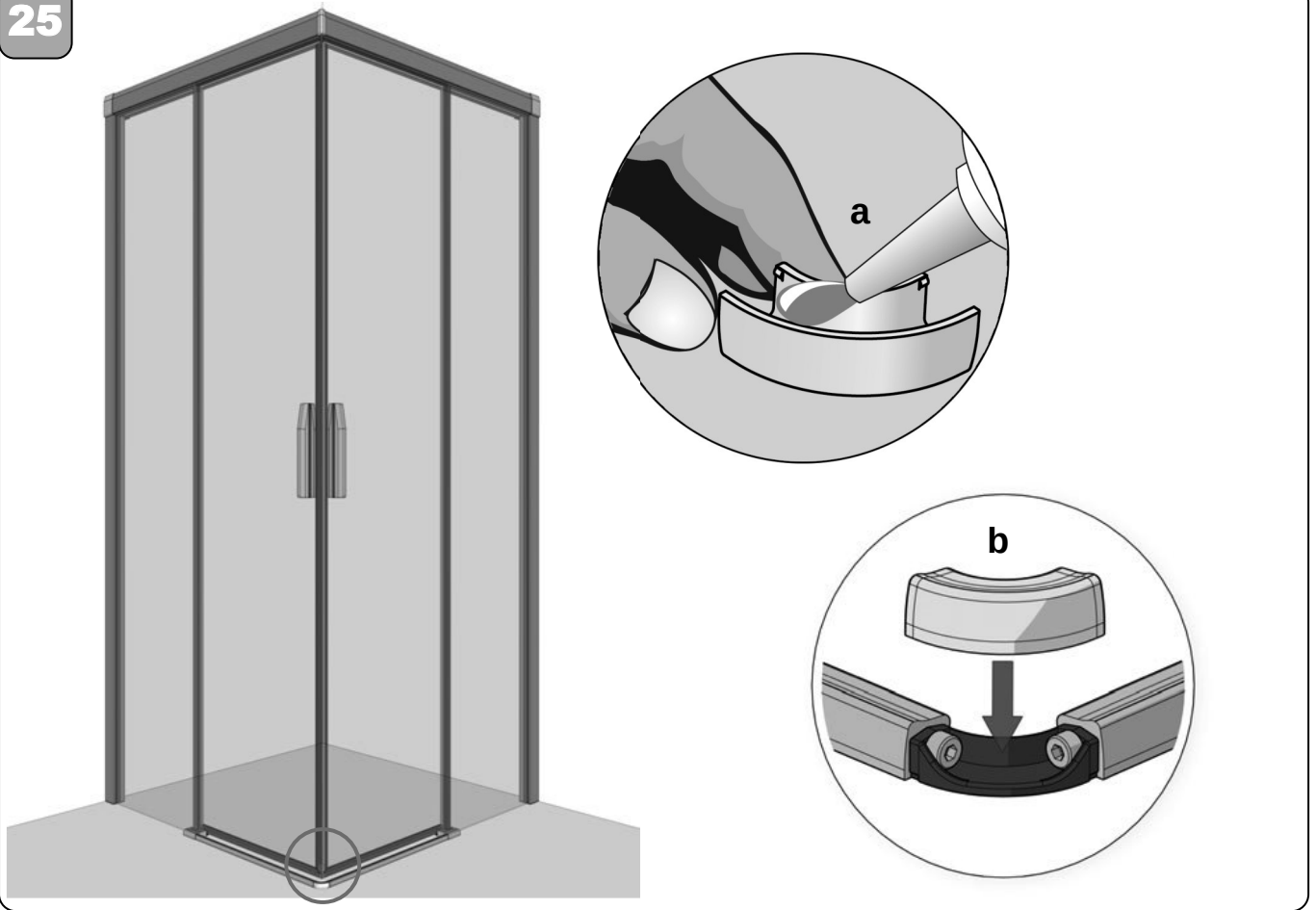

26



Ersatzteile

Eckeinstieg, 2 Schiebetüren und 2 Fixteile

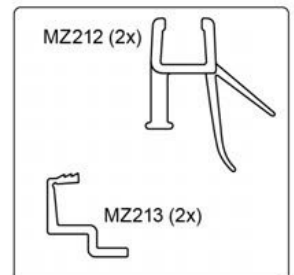
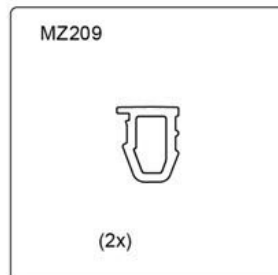
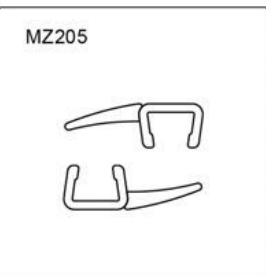
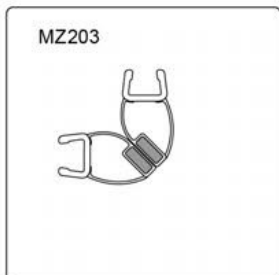
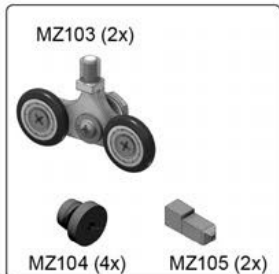
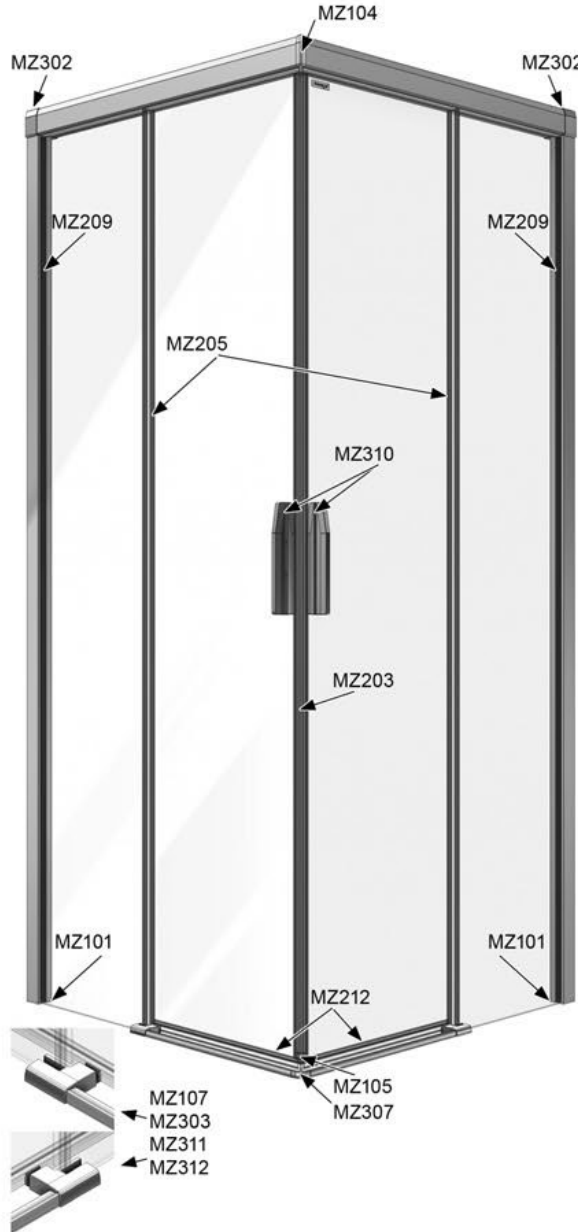
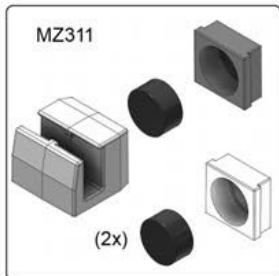
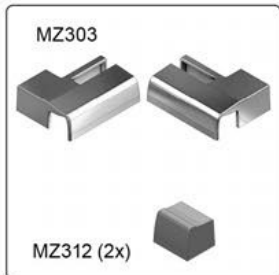
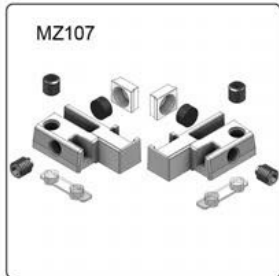
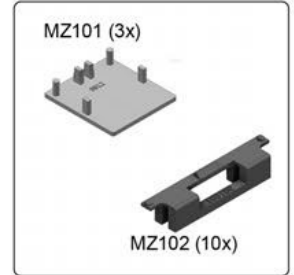
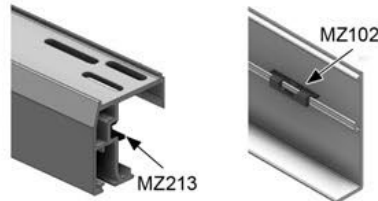
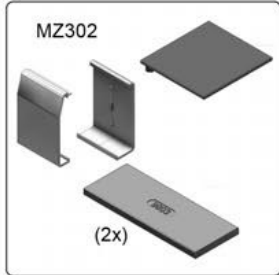

Artweger GmbH. & Co. KG

Sulzbacherstraße 60
4820 Bad Ischl, Austria
info@artweger.at
www.artweger.at
Tel.: +43 6132 205-0
Fax: +43 6132 205-5001

Für Deutschland:

Artweger GmbH. & Co. KG

Postfach 1169
D-83402 Ainring
info@artweger.de
www.artweger.de
Tel.: 0800 1114442-0
Fax: 0800 1114442-5002

Für Schweiz:

Artweger GmbH. & Co. KG

Postfach 16
CH-4202 Duggingen
info@artweger.com
www.artweger.com
Tel.: +41 61 751 90 91
Fax: +41 61 751 63 54



Druck- und Satzfehler sowie technische Änderungen vorbehalten.
Typographical errors and technical changes reserved.
Sous réserve d'erreurs d'impression ou de syntaxe ainsi que de modifications techniques.
Drukfouten, maatwijzingen en technische veranderingen voorbehouden.
Ci riserviamo errori di stampa e variazioni tecniche.