

## MONTAGEANLEITUNG

**Pendeltür in Nische** mit 2 Fixteilen, teilgerahmt

**PR4.** ..

## ASSEMBLY INSTRUCTIONS

**Swinging door in alcove** with 2 fixed parts, partially framed

**PT4.** ..

## NOTICE DE MONTAGE

**Porte battante en niche** avec 2 parties fixes, au cadre réduit

## MONTAGEVOORSCHRIFT

**Pendeldeur in nis** met 2 vaste deelen, profiel beperkt

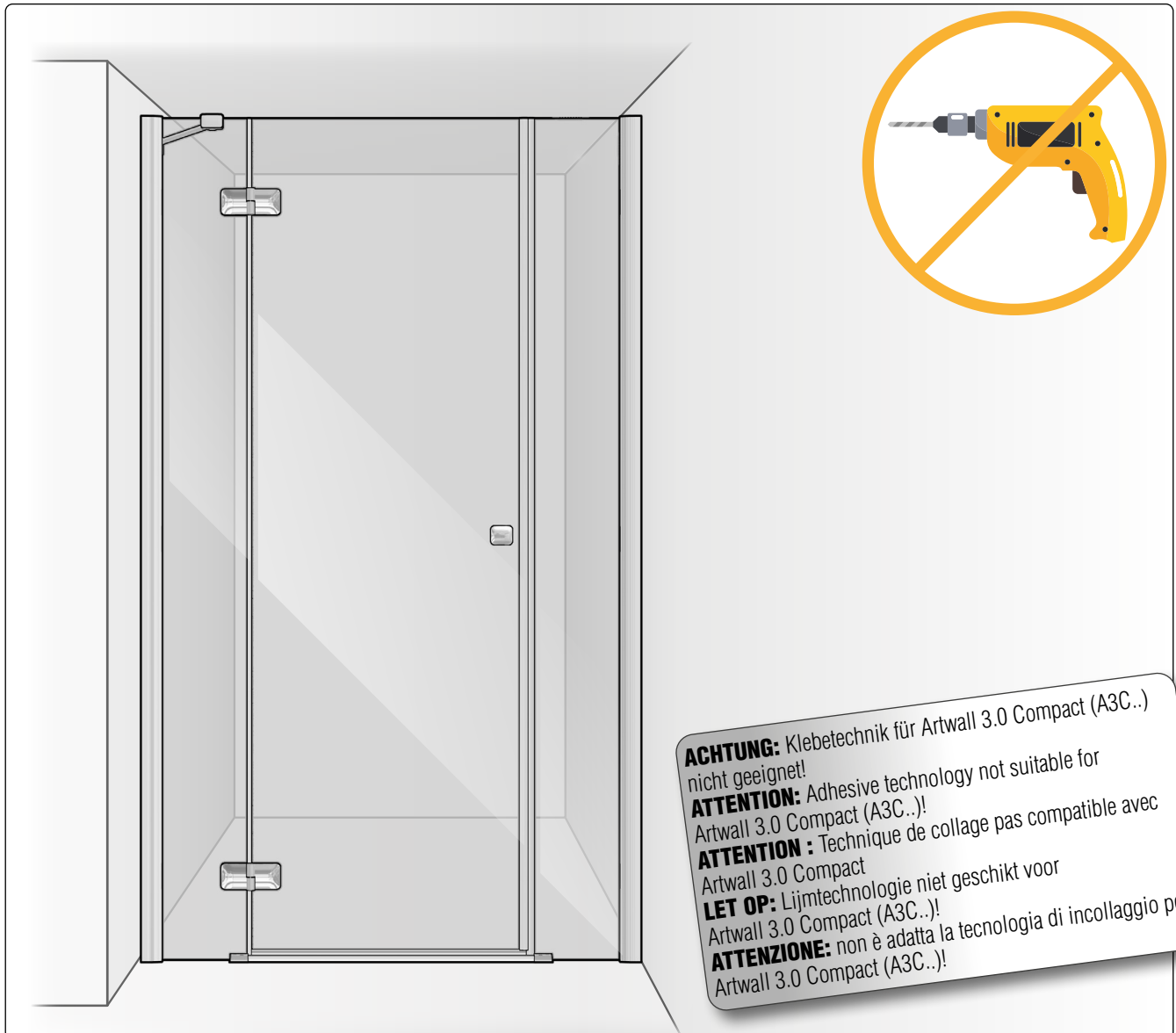

**ACHTUNG:** Klebetechnik für Artwall 3.0 Compact (A3C..) nicht geeignet!  
**ATTENTION:** Adhesive technology not suitable for Artwall 3.0 Compact (A3C..)!  
**ATTENTION :** Technique de collage pas compatible avec Artwall 3.0 Compact  
**LET OP:** Lijmtechnologie niet geschikt voor Artwall 3.0 Compact (A3C..)!  
**ATTENZIONE:** non è adatta la tecnologia di incollaggio per Artwall 3.0 Compact (A3C..)!

**Vor Gebrauch sorgfältig lesen!** Zum Nachschlagen und Aufbewahren dem Endkunden übergeben!

**Read carefully before use!** Hand over to the customer for looking up and storage!

**Avant emploi lire soigneusement!** Remettez le au client pour la recherche et le stockage!

**Voordien gebruik zorgvuldig lezend!** Overhandig de klant voor het kijken omhooggaand en opslag!

**DEUTSCH**  
Originalsprache

**ENGLISH**  
Translation

**FRANCAIS**  
Traduction

**NEDERLANDS**  
Vertaling

INHALTSVERZEICHNIS	OVERVIEW
INHALTSVERZEICHNIS .....2	OVERVIEW .....2
SICHERHEITS-HINWEISE.....4	SAFETY INSTRUCTIONS .....4
BENÖTIGTES WERKZEUG .....6	NECESSARY TOOLS .....6
MONTAGESET .....7	ASSEMBLY KIT .....7
MONTAGEVARIANTEN .....8	ASSEMBLY VARIATIONS .....8
VERSTELLBEREICH .....8	ADJUSTMENT RANGE .....8
MONTAGEVARIANTEN .....9	ASSEMBLY VARIATIONS .....9
WANNEN- EINBAUMASS .....9	TRAY INSTALLATION MEASUREMENT .....9
HINWEISE ..... 10	INSTRUCTIONS ..... 10
MONTAGE ..... 11	ASSEMBLY ..... 11
» MONTAGE FIXTEIL ..... 11	» INSTALLATION OF IMMOVABLE ELEMENT ..... 11
» JUSTIEREN ..... 15	» ADJUST ..... 15
» MONTAGE STABILISATOR ..... 17	» INSTALLATION OF STABILIZER ..... 17
» MONTAGE TÜR.....22	» INSTALLATION DOOR.....22
» MONTAGE GRIFF .....22	» INSTALLATION OF HANDLE .....22
» MONTAGE DICHTLEISTEN .....25	» INSTALLATION OF SEALING STRIP .....25
» ABDICHTEN MIT SANITÄRSILIKON .....27	» SEALING WITH SANITARY SILICONE .....27
ERSATZTEILE .....30	SPARE PARTS.....30
 <b>Montageanleitung für Einbau LINKS -</b> bei Einbau RECHTS - spiegelgleicher Aufbau.	 <b>Assembly instructions for installation LEFT -</b> for installation RIGHT - assemble in mirror image.

VUE D'ENSEMBLE	OVERZICHT
VUE D'ENSEMBLE .....3	OVERZICHT .....3
INSTRUCTIONS SÉCURIT .....4	VEILIGHEIDS VOORSCHRIFTEN .....4
OUTILLAGE NECESSAIRE .....6	BENODIGD GEREEDSCHAP .....6
SET DE MONTAGE.....7	MONTAGESET .....7
VARIANTES DE MONTAGE .....8	MONTAGEVARIANTEN .....8
POSITIONNEMENT .....8	VERSTELBAARHEID.....8
VARIANTES DE MONTAGE .....9	MONTAGEVARIANTEN .....9
MESURES POUR MONTAGE SUR RECEVEUR.....9	DOUCHEBAK- INBOUWMAAT.....9
INSTRUCTIONS ..... 10	INFORMATIE..... 10
MONTAGE ..... 11	MONTAGE ..... 11
» MONTAGE PARTIE FIXE ..... 11	» MONTAGE VAST DEEL ..... 11
» AJUSTER ..... 15	» GOED AFSTELLEN ..... 15
» MONTAGE STABILISATEUR ..... 17	» MONTAGE STABILISATOR ..... 17
» MONTAGE DE LA PORTE .....22	» MONTAGE DEUR.....22
» MONTAGE POIGNÉE.....22	» MONTAGE GREEP .....22
» MONTAGE BAGUETTES D'ÉTANCHÉITÉ .....25	» MONTAGE AFDICHTINGEN .....25
» ETANCHER AVEC DU SILICONE SANITAIRE.....27	» AFDICHTEN MET SANITAIR-SILICONEN.....27
PIÈCES DÉTACHÉES .....30	ONDERDELEN .....30

**C'est prévue pour une installation à GAUCHE –**  
en cas d'une installation à DROITE -A inverser pour partie fixe en GAUCHE.

**Montagevoorschrift voor inbouw LINKS -**  
bij inbouw RECHTS - montage in spiegelbeeld.

## SICHERHEITS-HINWEISE

## SAFETY INSTRUCTIONS

## INSTRUCTIONS SÉCURIT

## VEILIGHEIDS VOORSCHRIFTEN

### DE Vor dem Einbau bitte unbedingt beachten!

- Produkt **vor dem Einbau**, auf Richtigkeit, Beschädigungen und das Zubehör auf Vollständigkeit **überprüfen**.
- **Bei sichtbarem Schaden Produkt keinesfalls einbauen!**
- **Beachten Sie beim Hantieren das teilweise hohe Gewicht und/oder die großen Abmessungen von Einzelteilen.**

Unsere Haftung beschränkt sich alleine auf unsere Produkte und kann daher nicht auf den Ein- und Ausbau ausgedehnt werden. Die Kosten für einen nachträglichen Aus- und Einbau eines Produkts und die damit verursachten Schäden sind **kein** Bestandteil der Garantie.

### EN Please note carefully before installing

- Before installing, check for correctness and damage and the accessories for completeness.
- **Do not under any circumstances install product with visible damage!**
- **Take the great weight and/or the large dimensions into consideration when handling individual parts!**

Our liability is limited to our products alone and therefore cannot be extended to installation and dismantling. Costs for subsequent dismantling and installation of a product and damage caused thereby are not part of the guarantee.

### FR A respecter impérativement avant le Montage

- Avant le montage de vérifier qu'il s'agit du bon modèle, qu'elle n'est pas endommagée et que les accessoires sont complets.
- **En cas de dommages visibles, ne pas monter le produit!**
- **Lors de la manutention, merci de prêter attention au poids parfois très élevé et/ou aux dimensions de certaines pièces!**

Notre responsabilité se limite à nos produits et ne peut être étendue sur l'installation et le démontage. Les coûts générés lors d'un démontage après installation et d'une ré-installation d'un produit et les dommages qui en résultent ne pourront être pris en charge par la garantie.

### NL Voor inbouw beslist in acht nemen!

- Bad voor het inbouwen op juistheid, beschadigingen en toebehoren op volledigheid controleren.
- **Bij zichtbare beschadiging product in geen geval inbouwen!**
- **Let u bij het gebruik om het gedeeltelijk grote gewicht en/of de grote afmetingen van enkele onderdelen!**

Wanneer het bad betegeld wordt, beslist de inbouwmaten van de badkuip en van de doucheafscheiding in acht nemen. Onze aansprakelijkheid is beperkt tot onze producten en kan daarom niet op de in- en uitbouw uitgebreid worden. De kosten voor een latere uit- en inbouw van een product en de daaruit voortvloeiende schade zijn geen onderdeel van de garantie.

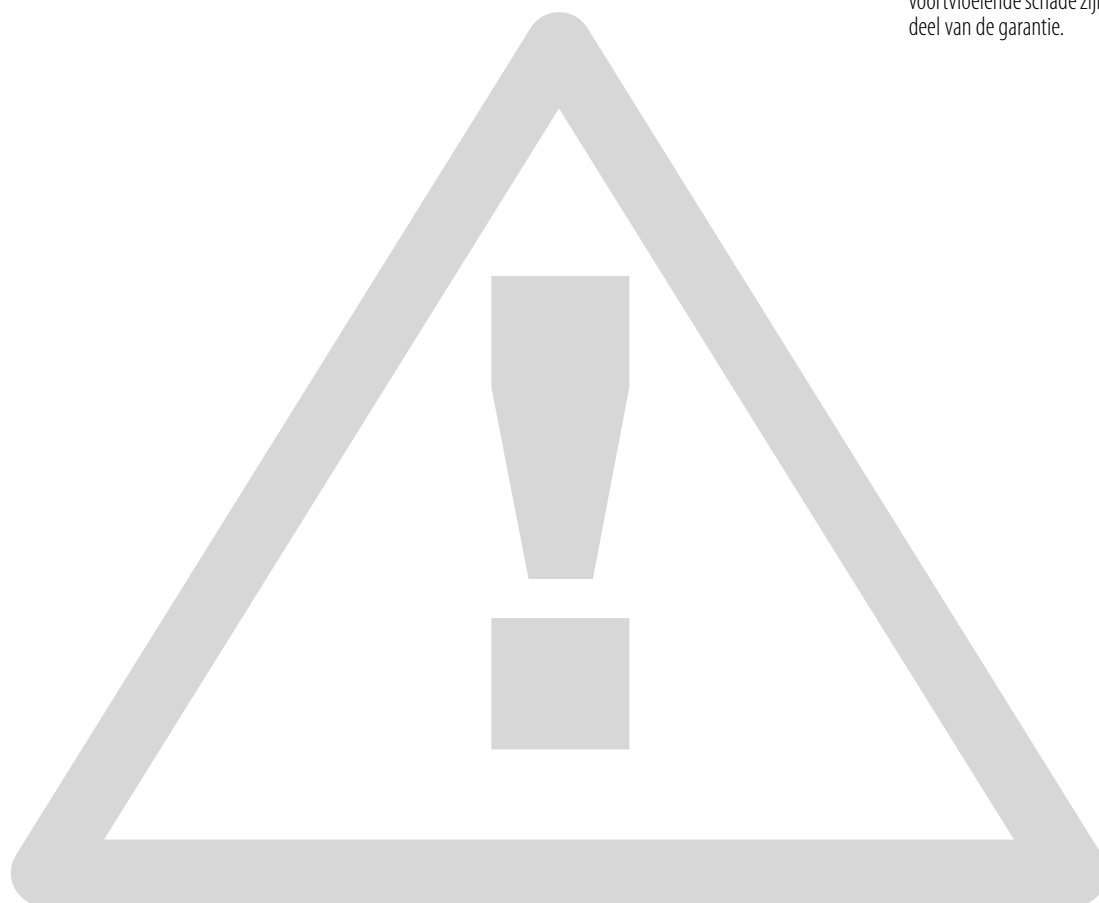



**DE ACHTUNG!**  
**Beim Hantieren**  
**mit Glas Schutz-**  
**kleidung tragen!**

Bitte untersuchen Sie nach dem Auspacken das Einscheiben-Sicherheitsglas (ESG) unverzüglich auf mögliche Transportschäden, wie abgesprungene Kanten oder Ecken. Wird ein Schaden festgestellt bitte umgehend Schadensmeldung machen und die Scheibe nicht einbauen, da dieser Fehler auch später zu einem Bruch führen kann! Alle Gläser werden vor dem Verpacken sorgfältig kontrolliert. Spätere Reklamationen, auch bei Bruch, können daher nicht anerkannt werden.

**EN ATTENTION!**  
**Wear protective**  
**clothing when**  
**handling glass!**

Please examine the single-pane safety glass for possible transport damage such as chipped edges or corners immediately after unpacking. If damage is detected do not install the pane because a defect can lead to breakage later! Please make a damage report without delay! All glass panes are controlled with utmost care before packing. Therefore later complaints cannot be acknowledged, even in case of breakage.

**FR ATTENTION !**  
**Portez des**  
**vêtements**  
**protecteurs en**  
**manipulant du**  
**verre.**

Merci de vérifier immédiatement le verre de sécurité monofeuille au déballage sur d'éventuels dommages survenus au transport, tels que chants et angles écaillés. Si toutefois un défaut a été constaté, merci d'en faire la déclaration au plus vite et ne pas monter la vitre, car ce défaut peut être, par la suite, à

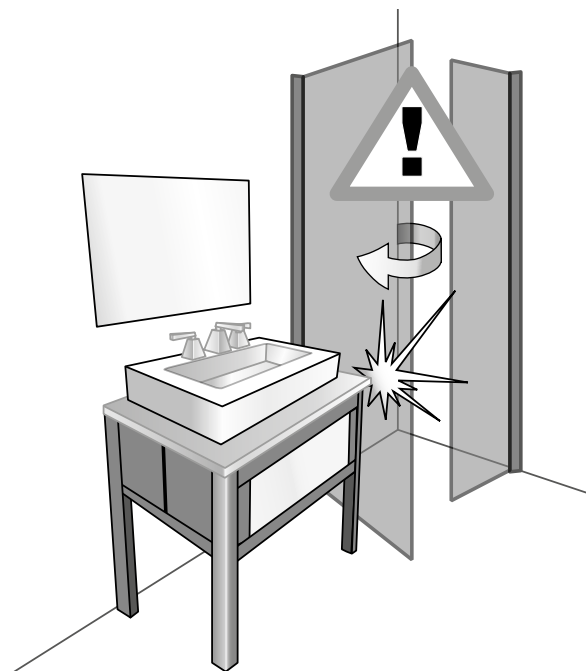

l'origine d'une casse! Tous les verres sont contrôlés minutieusement avant le conditionnement. Pour cette raison, aucune réclamation ultérieure, même en cas de casse, ne pourra être prise en compte.

Na het uitpakken het enkel veiligheidsglas (ESG) onmiddellijk op mogelijke transport- beschadigingen, zoals afgesprongen kanten of hoeken, controleren. Wordt een beschadiging vastgesteld, dan mag het glas niet worden ingebouwd, omdat deze schade ook later tot een breuk kan leiden !Bij een vastgestelde schade, meldt dit onmiddellijk! Al het glas wordt voor het verpakken zorgvuldig gecontroleerd. Latere reclames, ook bij breuk, kunnen daarom niet geaccepteerd worden.

**NL ATTENTIE !**  
**Bij het hanteren**  
**van glas be-**  
**schermde kle-**  
**ding dragen!**

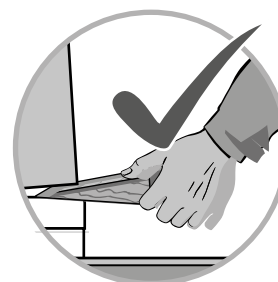
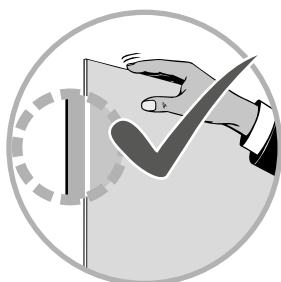
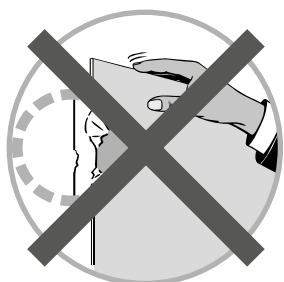
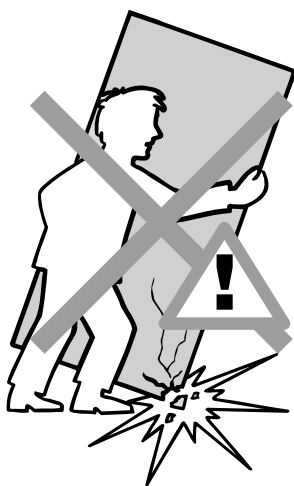

BENÖTIGTES WERKZEUG

NECESSARY TOOLS

OUTILLAGE NECESSAIRE

BENODIGD GEREEDSCHAP

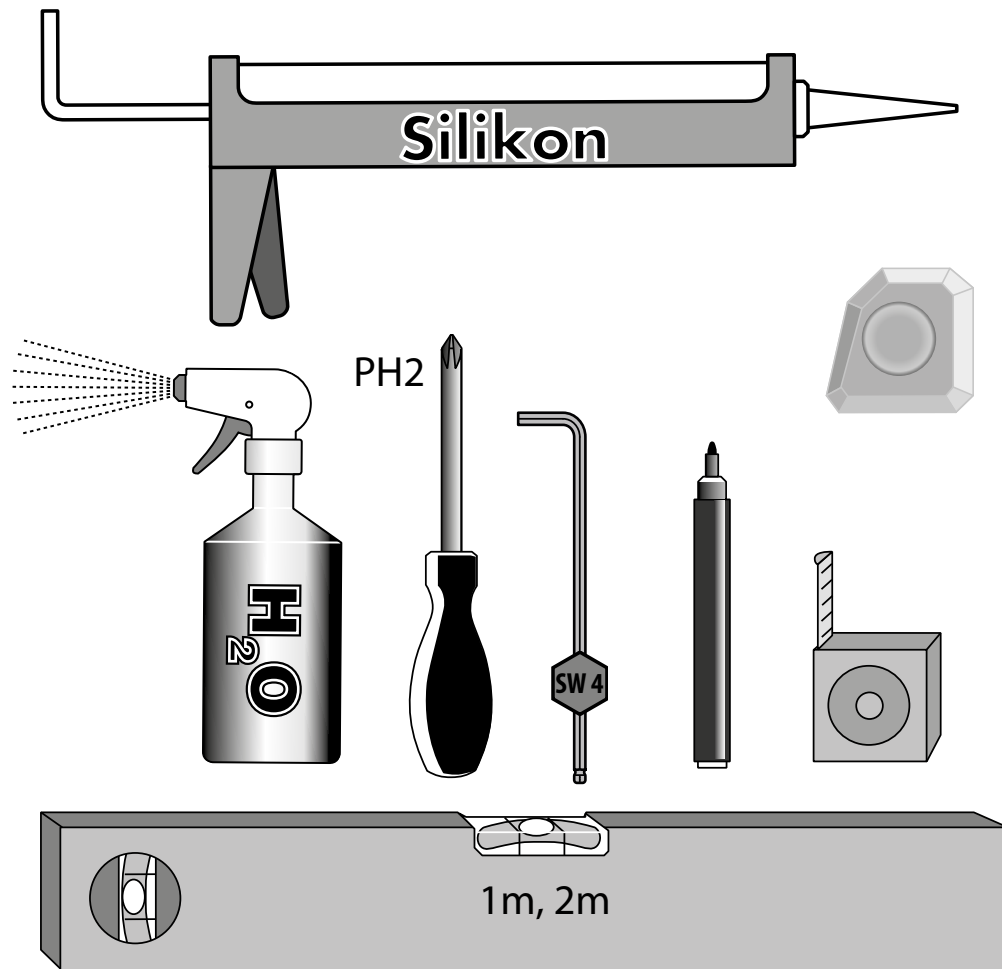

MONTAGESET	ASSEMBLY KIT	SET DE MONTAGE	MONTAGESET
<p><b>12x</b> 4,8X60mm MatNr: 24466</p> 	<p><b>14x</b> 125A-5,3-A2 MatNr: 2430</p> 	<p><b>12x</b> Ø 8mm MatNr: 24409</p> 	<p><b>2x</b> M8x5mm MatNr: 24412</p> 
<p><b>4x</b> MatNr: 705722</p> 	<p><b>4x</b> MatNr: 705723</p> 	<p><b>2x</b> MatNr: 704520</p> 	<p><b>2x</b> DIN 916 - M8x8mm MatNr: 24329</p> 
<p><b>1x</b> MatNr: 705603 1 / 2 N</p> 	<p><b>1x</b> MatNr: 705605</p> 	<p><b>2x</b> MatNr: 705706</p> 	<p><b>1x</b> MatNr: 33176</p> 
<p><b>1x</b> MatNr: 181026</p> 	<p><b>1x</b> MatNr: 181010</p> 	<p><b>1x</b> MatNr: 33183</p> 	<p><b>3x</b> MatNr: 33184</p> 
<p><b>1x</b> DIN 965 - M4x10mm MatNr: 2444</p> 	<p><b>4x</b> MatNr: 181016</p> 		
<p><b>2x</b> 4,2x38mm MatNr: 24467</p> 	<p><b>2x</b> Ø 6mm MatNr: 24410</p> 		
<p>Verwendung optional   Use optional Utilisation en option   Gebruik optionele</p>	<p>Verwendung optional   Use optional Utilisation en option   Gebruik optionele</p>		

**MONTAGEVARIANTEN**

**ASSEMBLY VARIATIONS**

**VARIANTES DE MONTAGE**

**MONTAGEVARIANTEN**



**DE** Montage ohne Duschwanne.

**FR** Montage sans receveur de douche.

**EN** Assembly without shower tray.

**NL** Montage zonder douchebak.

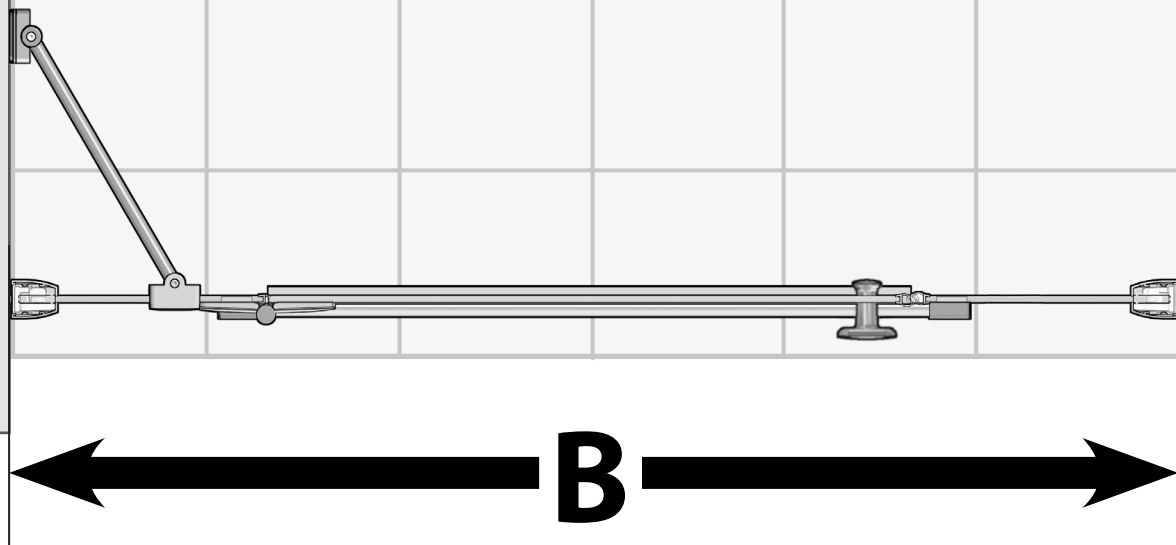

**VERSTELLBEREICH**

**ADJUSTMENT RANGE**

**POSITIONNEMENT**

**VERSTELBAARHEID**

**Auftrag Nr.:**

/

**Serie**

**B**

Sondergrößen • special sizes • mesures spéciales • speciale maten

**900**

863 - 903 mm

**B=**

**mm**

**1000**

963 - 1003 mm

**1200**

1163 - 1203 mm

- Ab Breite 1400 mm inkl. 1 Stabilisator.

- One stabiliser included with custom widths 1400 mm and wider.

- En cas de largeur à partir de 1400 mm inclus, 1 stabilisateur est fourni.

- Vanaf breedte 1400 mm incl. 1 stabilisator.



MONTAGEVARIANTEN

ASSEMBLY VARIATIONS

VARIANTES DE MONTAGE

MONTAGEVARIANTEN

**DE** Montage auf Duschwanne.

**EN** Assembly on shower tray.

**FR** Montage sur un receveur de douche.

**NL** Montage op douchebak.

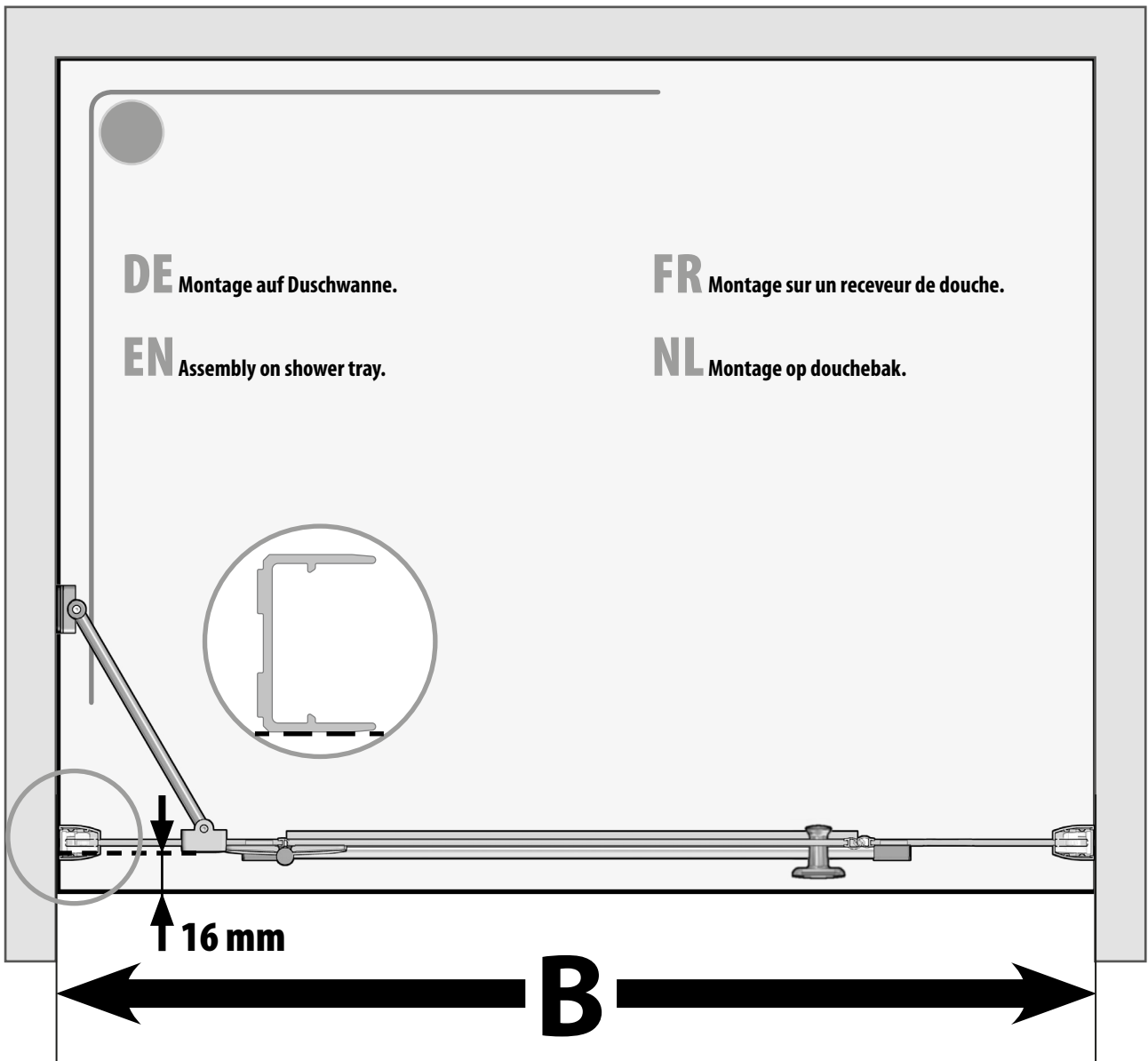

WANNEN-  
EINBAUMASS

TRAY INSTALLATION  
MEASUREMENT

MESURES POUR MONTAGE  
SUR RECEVEUR

DOUCHEBAK-  
INBOUWMAAT

Serie	B	
900	863 - 903 mm	
1000	963 - 1003 mm	
1200	1163 - 1203 mm	

- Ab Breite 1400 mm inkl. 1 Stabilisator.

- One stabiliser included with custom widths 1400 mm and wider.

- En cas de largeur à partir de 1400 mm inclus, 1 stabilisateur est fourni.

- Vanaf breedte 1400 mm incl. 1 stabilisator.

## HINWEISE

## INSTRUCTIONS

## INSTRUCTIONS

## INFORMATIE

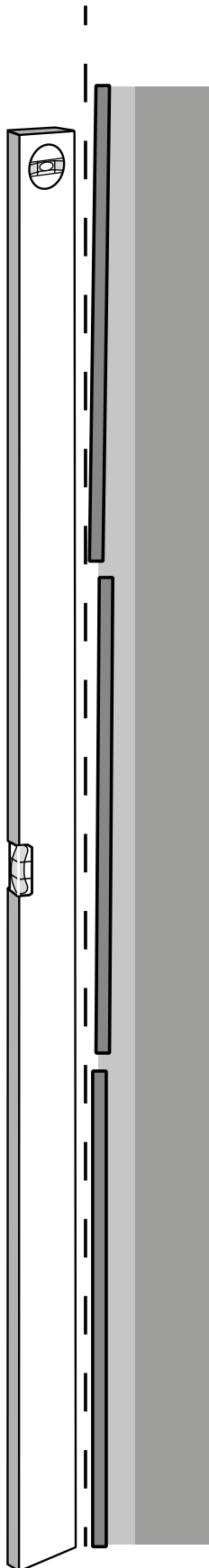

**DE** ART-FIX Klebesystem ist universell einsetzbar für alle Untergründe die vollflächig tragfähig, plan, staub- und fettfrei, gegen Feuchtigkeit abgedichtet und frei von haftungsmindernden Stoffen sind.

**Bei Abweichung der Planheit muss die Klebstoffmenge entsprechend angepasst werden.**

**EN** ART-FIX adhesive system is universally applicable for all substrates that are fully load-bearing, flat, free of dust and grease, sealed against moisture and free of adhesion-reducing substances.

**If the flatness deviates, the amount of adhesive must be adjusted accordingly.**

**FR** Le système de collage ART-FIX peut être universellement utilisé sur toutes les surfaces qui sont entièrement porteuses, planes, sans poussière et sans graisse, étanchées et exemptes de toute matière réduisant l'adhérence.

**Si la planéité diffère, la quantité de colle doit être ajustée en conséquence.**

**NL** Het ART-FIX kleefstelsel is universeel toepasbaar op alle oppervlakken die volledig dragend, vlak, stof- en vetvrij, afgedicht tegen vocht en vrij van hechtings- reducerende materialen zijn.

**Als de vlakheid afwijkt, moet de hoeveelheid lijm dienovereenkomstig worden aangepast.**

1

**DE ACHTUNG!** Eine **einwandfreie** Montage ist nur möglich wenn der Boden **waagrecht** und die Wände **senkrecht** sind. Bei Bedarf beiliegende **Unterlagsplättchen** verwenden!

**EN Attention:** Correct installation is only possible if the floor is horizontal and the walls are vertical.

If needed use the enclosed spacing plates!

**FR Attention:** Un montage impeccable n'est possible que si le sol est parfaitement plan et le murs droits. En cas de besoin utiliser les cales fournies !

**NL Let op:** Een perfecte montage is alleen mogelijk, als de bodem horizontaal en de wanden verticaal t.o.v. elkaar staan. Indien nodig, bijgevoegde onderlegplaatjes gebruiken.

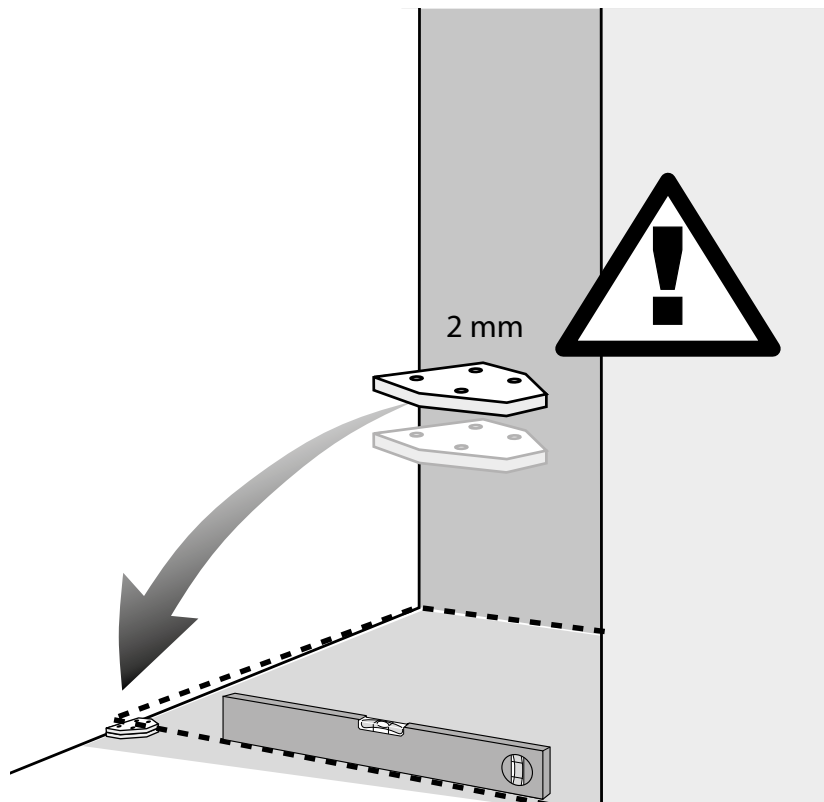

2

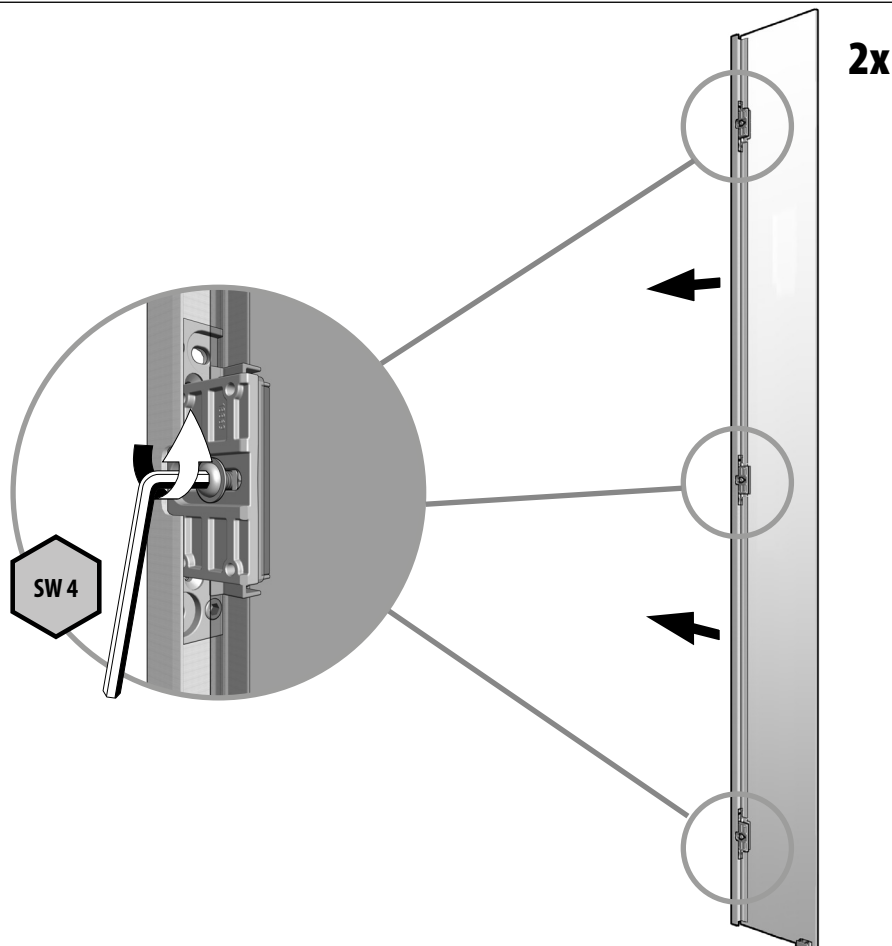

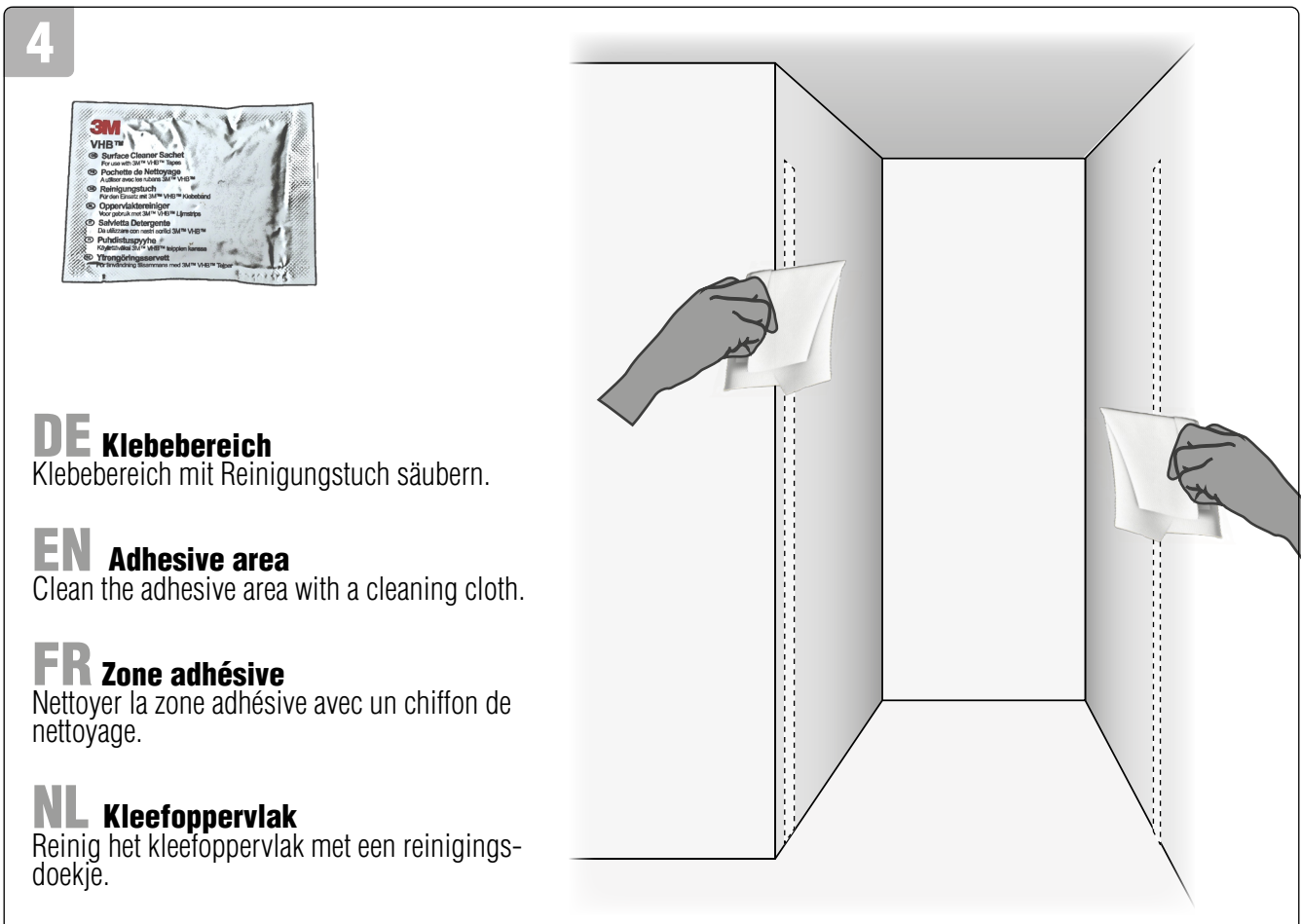
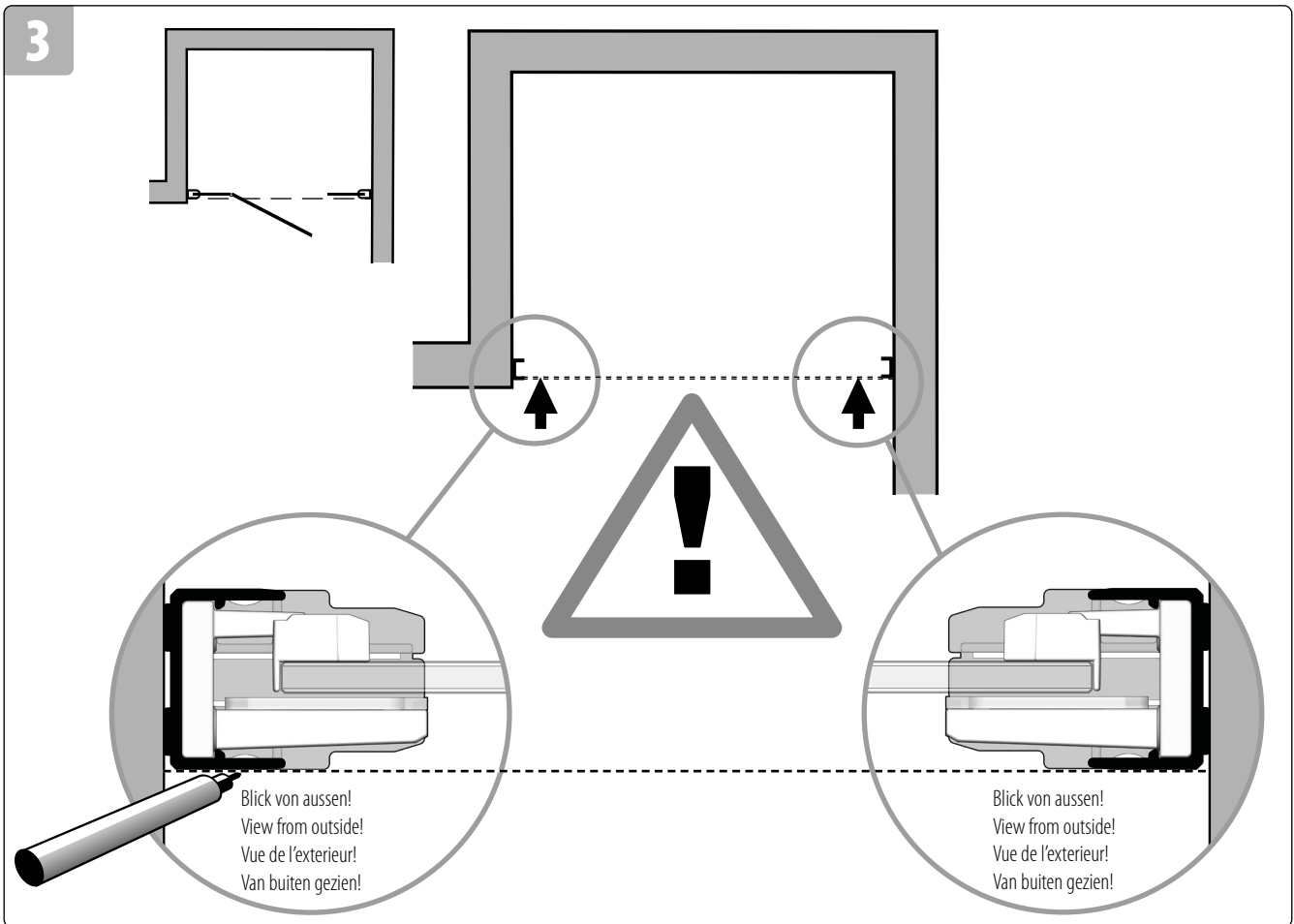

5

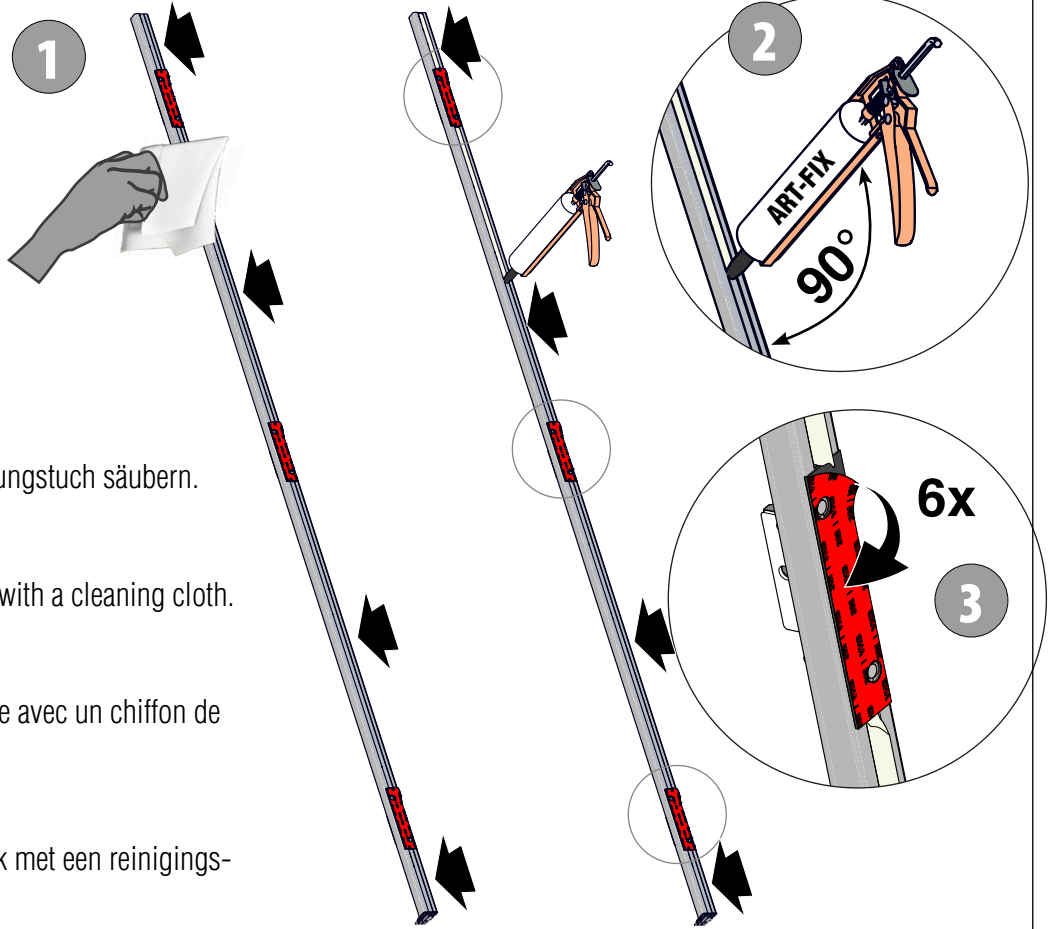
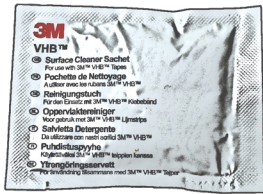

## DE Klebbereich

Klebbereich mit Reinigungstuch säubern.

## EN Adhesive area

Clean the adhesive area with a cleaning cloth.

## FR Zone adhésive

Nettoyer la zone adhésive avec un chiffon de nettoyage.

## NL Kleefoppervlak

Reinig het kleefoppervlak met een reinigingsdoekje.

6

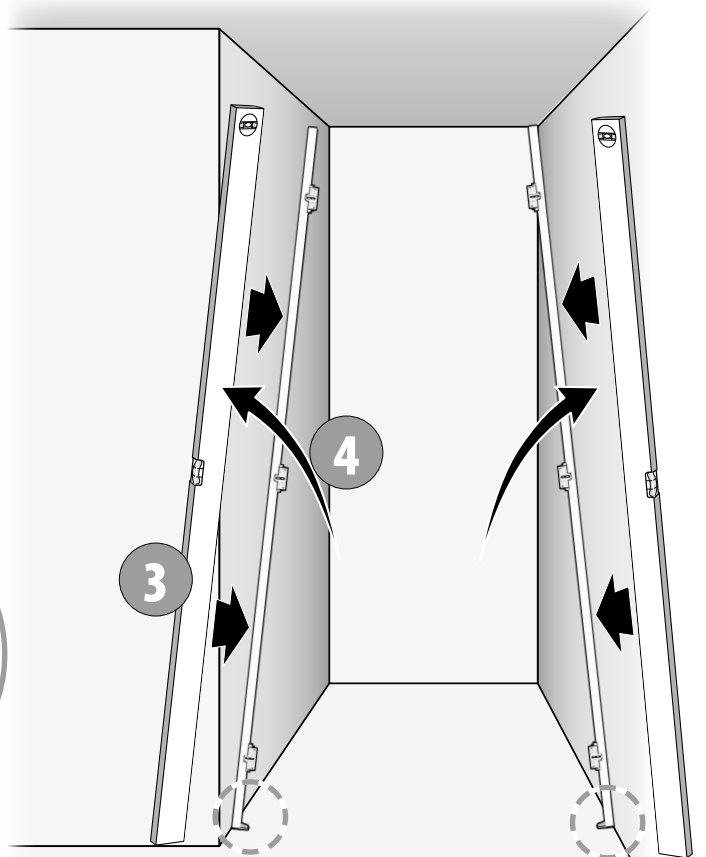
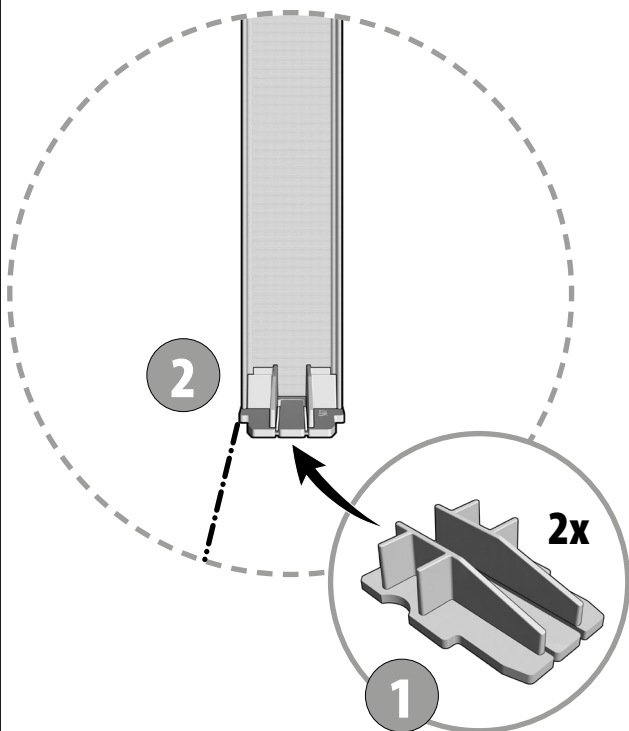

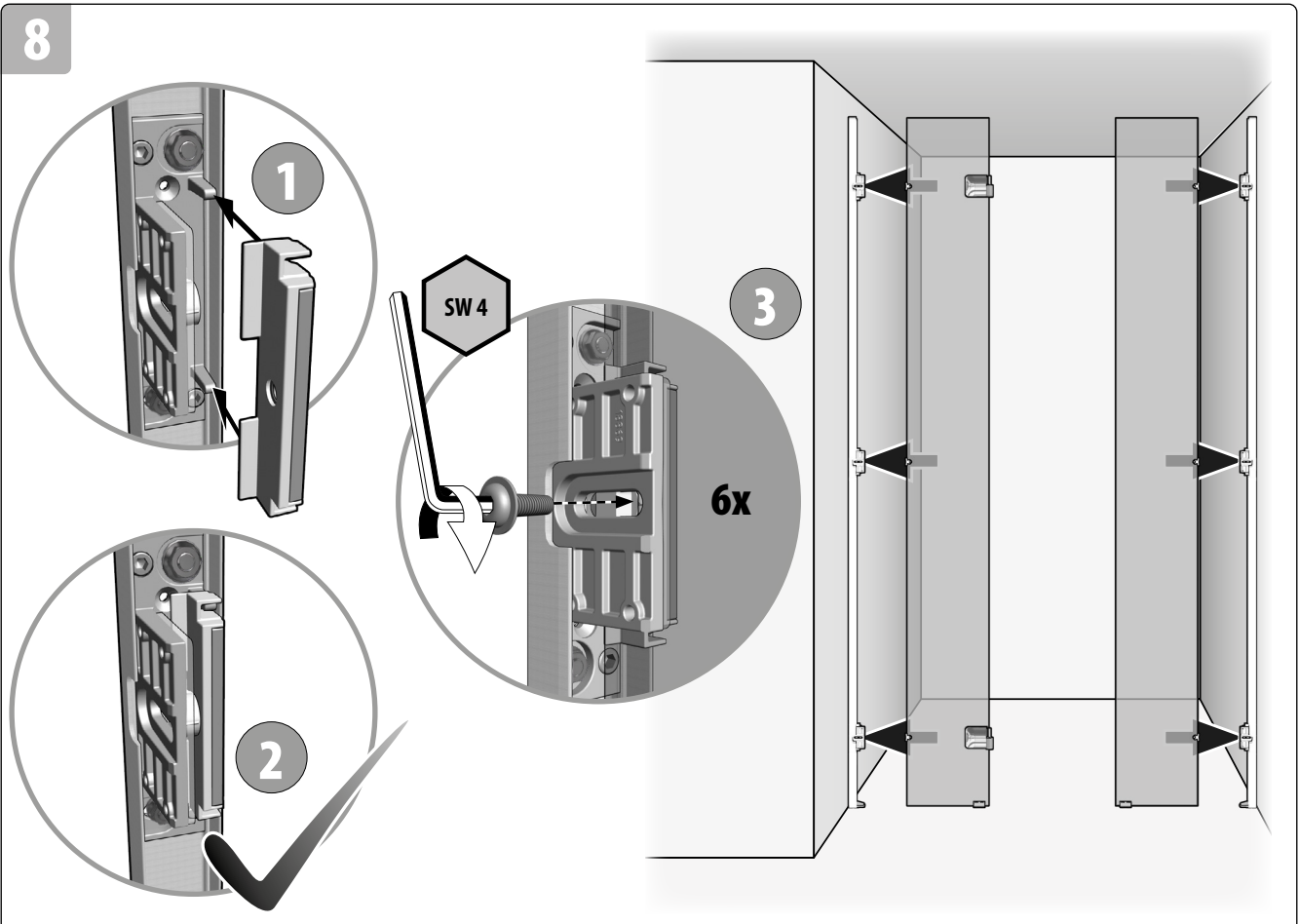
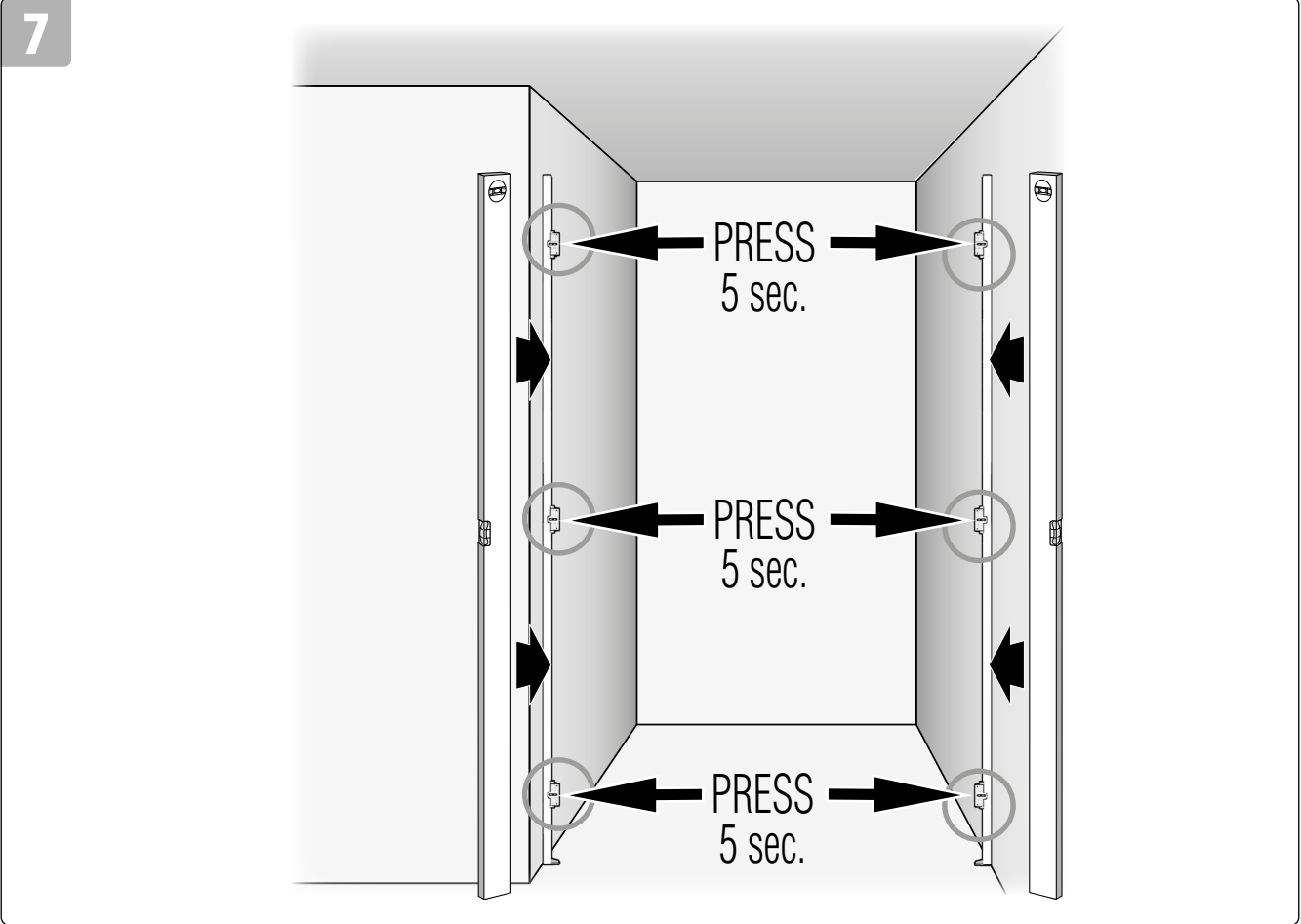

JUSTIEREN	ADJUST	AJUSTER	GOED AFSTELLEN
-----------	--------	---------	----------------

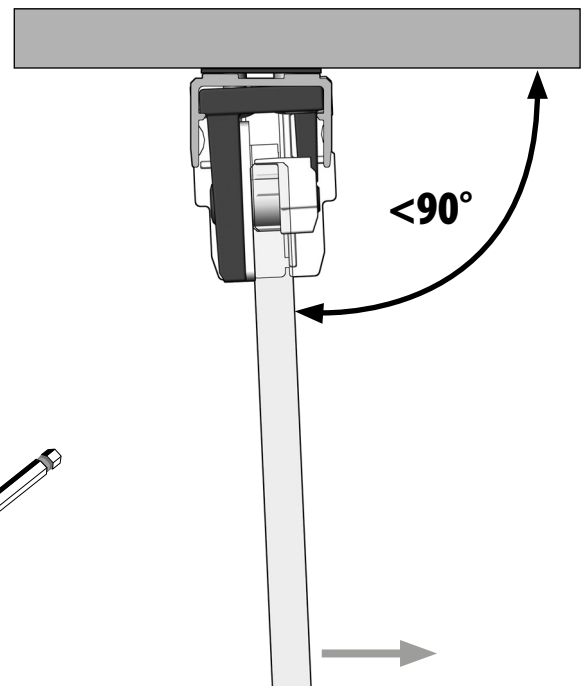
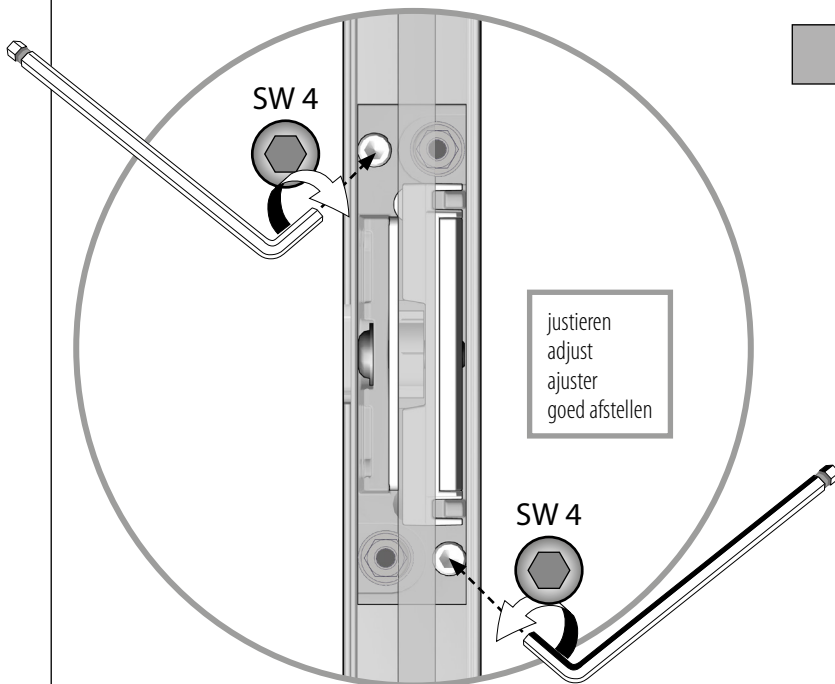
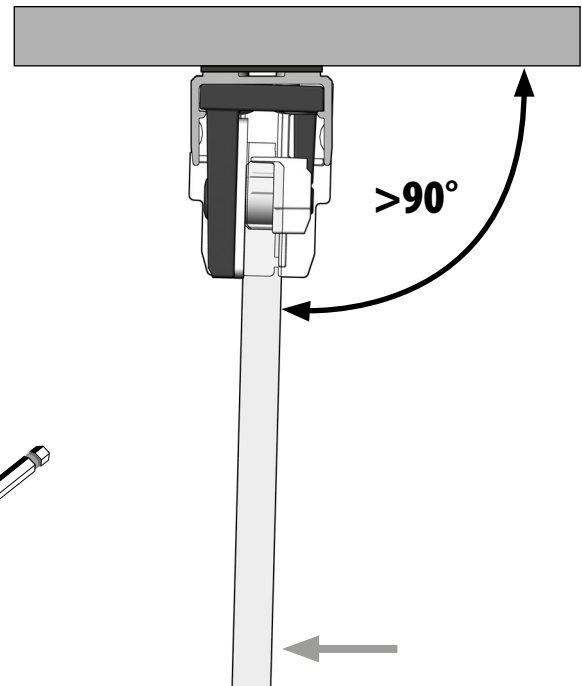
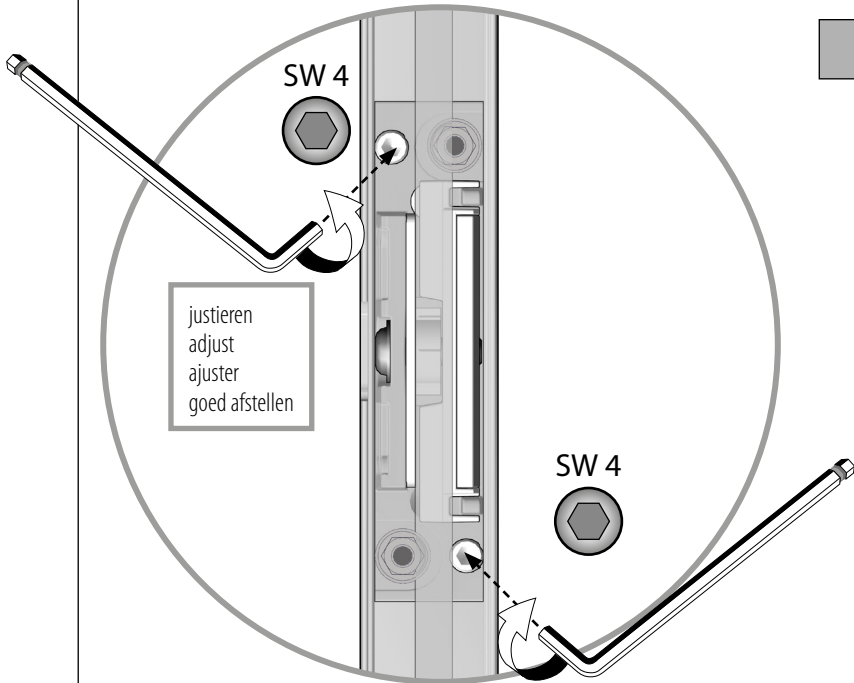

9

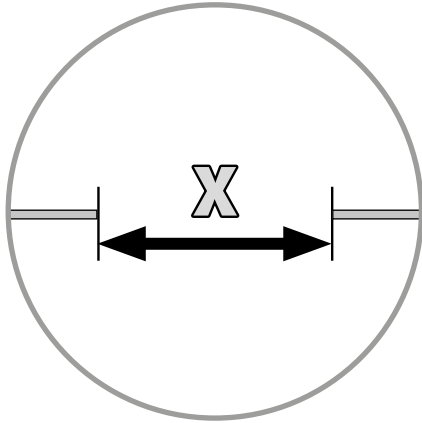

Dimension/ Serie	X =
900	572 mm
1000	622 mm
1200	722 mm
Sonder • special spéciales • speciale	<b>mm</b>

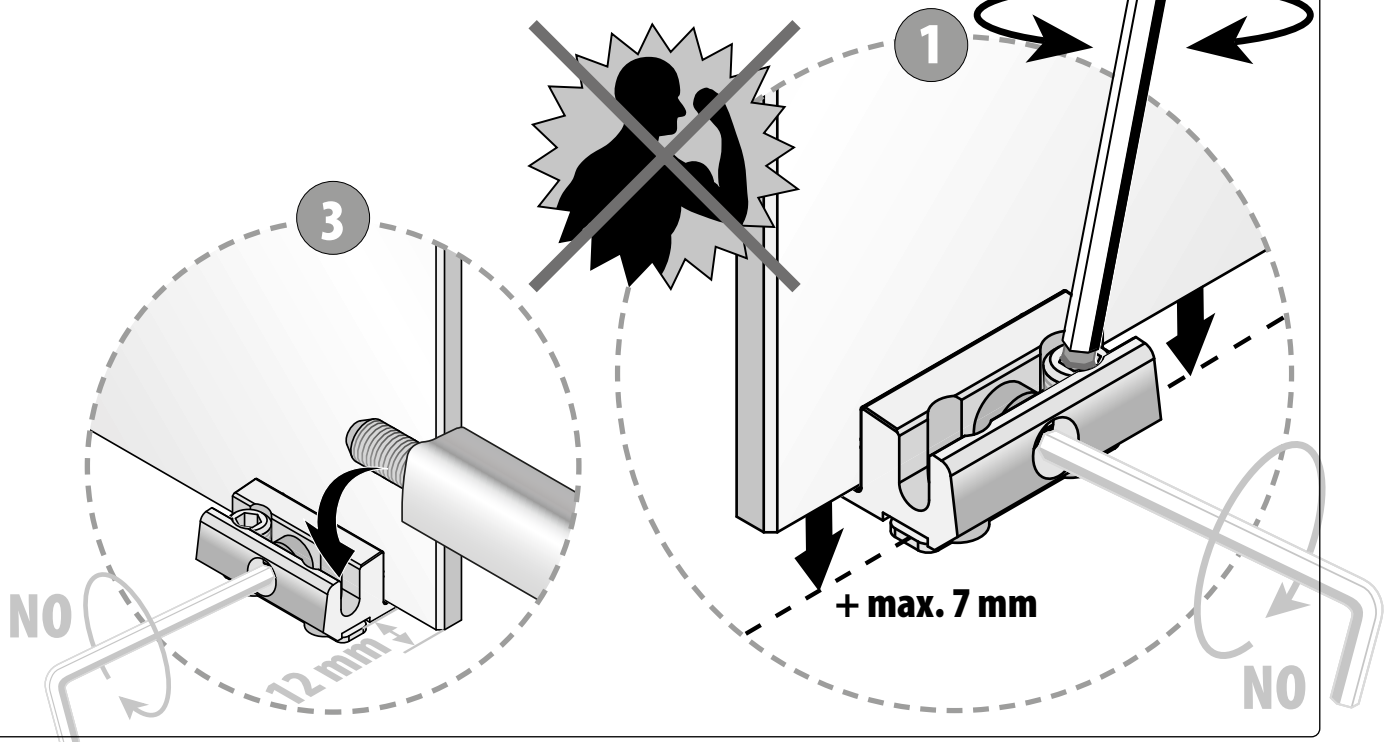
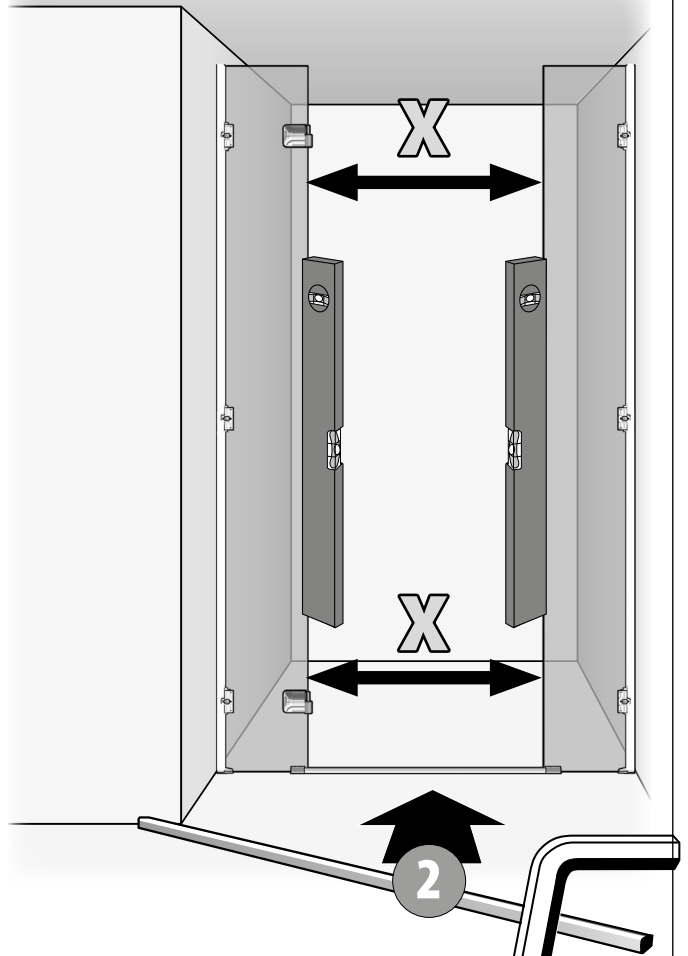



10

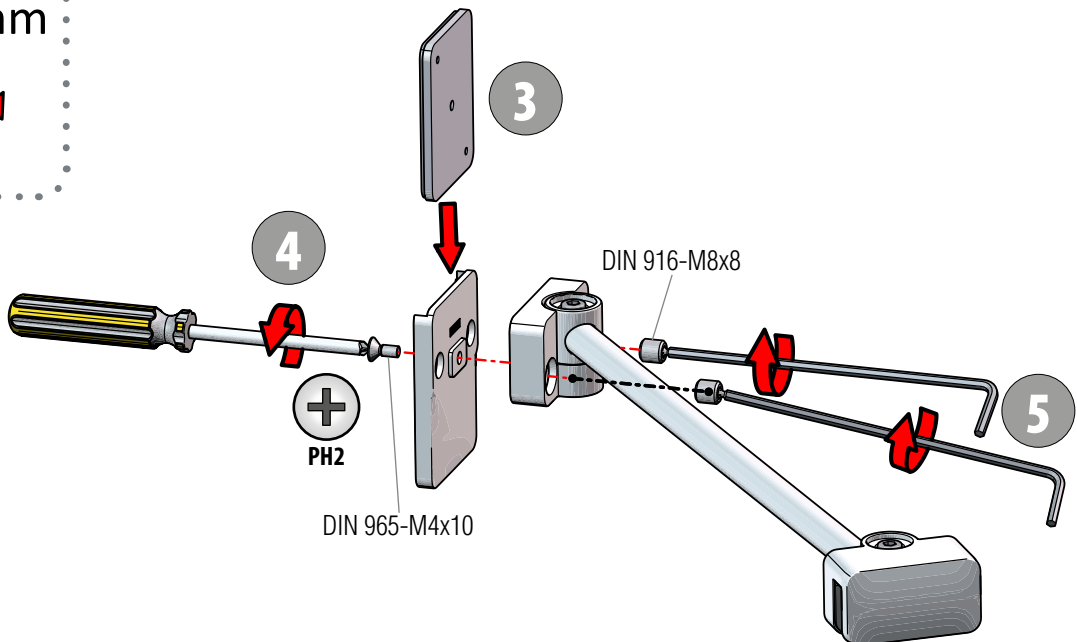
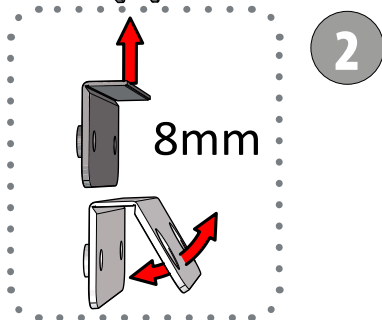
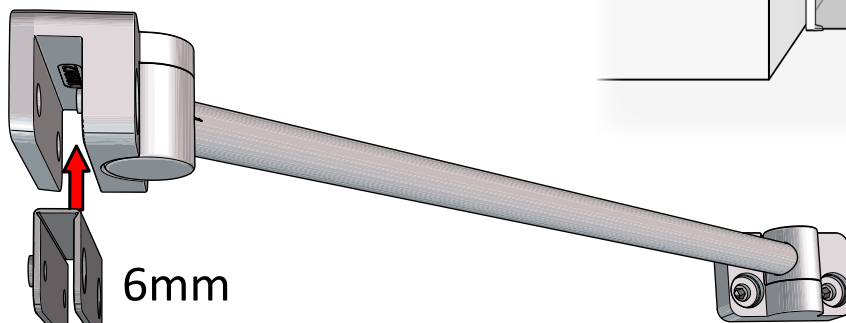
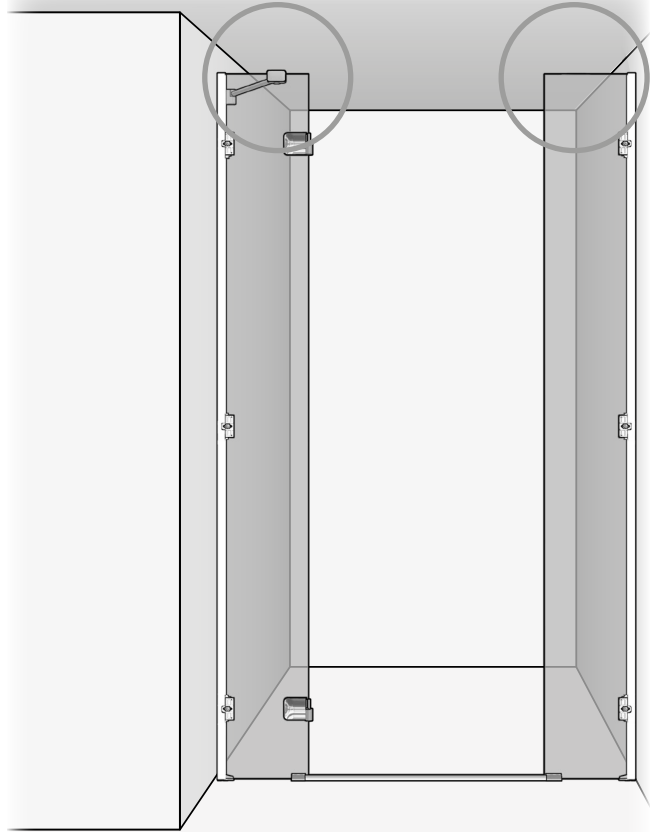
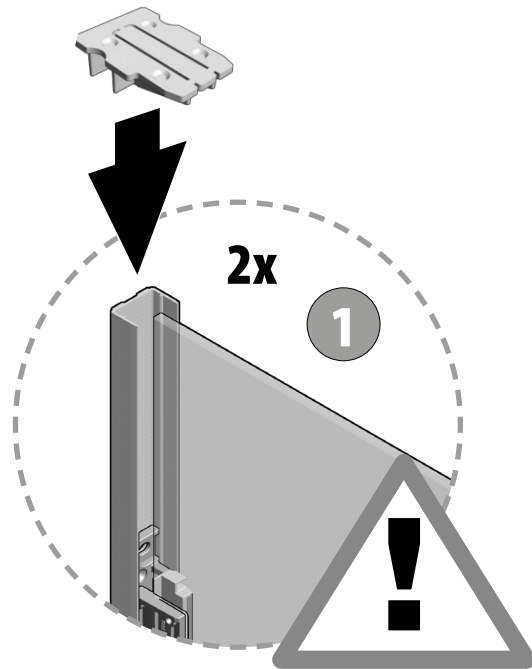

11

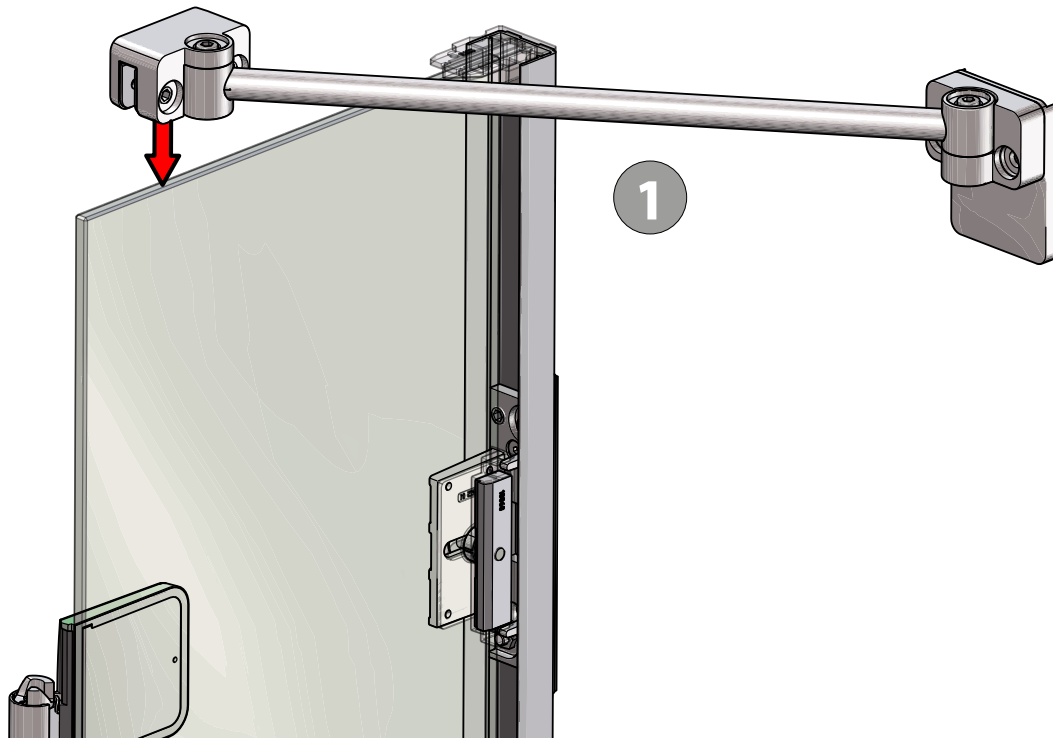

12

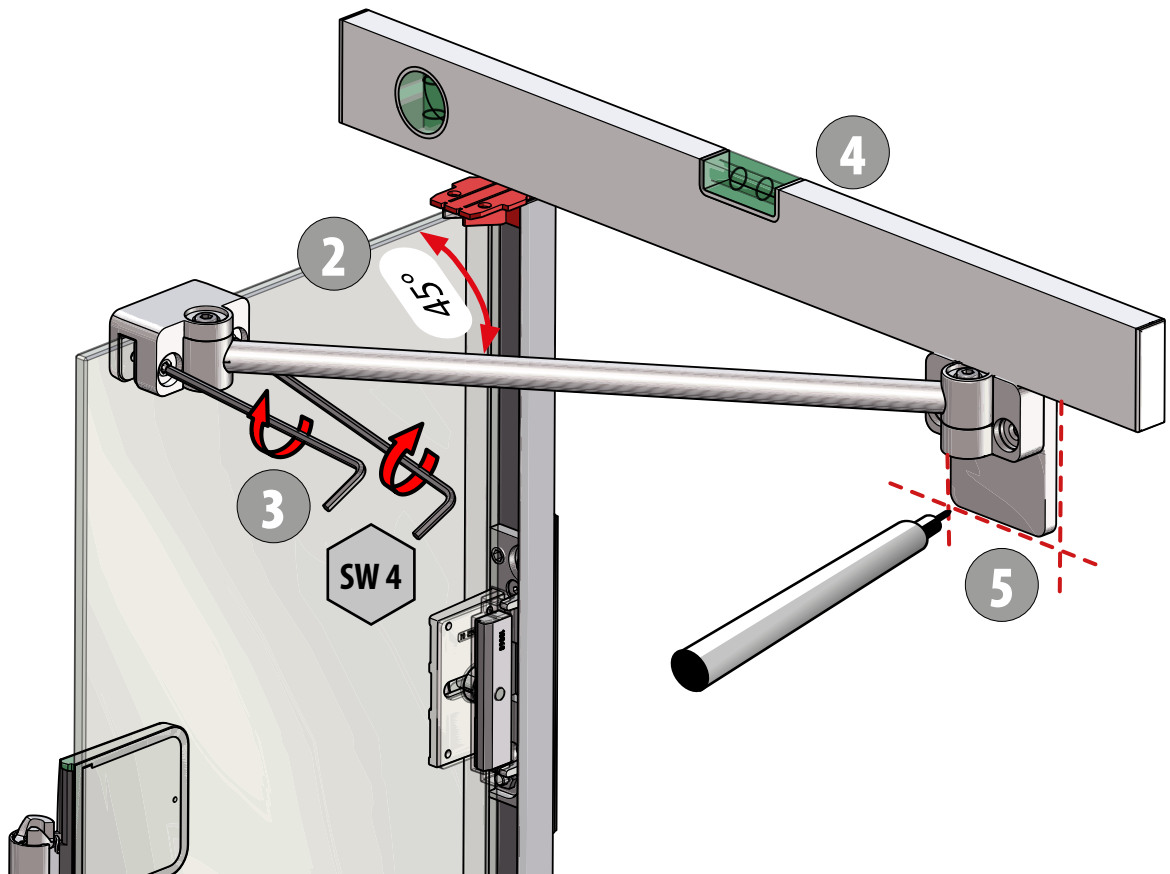

## 13 DE Klebbereich

- 2a. Klebbereich mit Reinigungstuch säubern.  
2b. Klebbereich mit Primerstift vorbehandeln und 2min ablüften lassen!

## EN Adhesive area

- 2a. Clean the adhesive area with a cleaning cloth.  
2b. Pre-treat the adhesive area with primer pen and let it air for 2 minutes!

## FR Zone adhésive

- 2a. Nettoyer la zone adhésive avec un chiffon de nettoyage.  
2b. Prétraiter la zone adhésive avec un crayon Primer et laisser aérer 2 minutes!

## NL Kleefoppervlak

- 2a. Reinig het kleefoppervlak met een reinigingsdoekje.  
2b. Behandel de te verlijmen zone voor met primer pen en laat 2 minuten drogen!

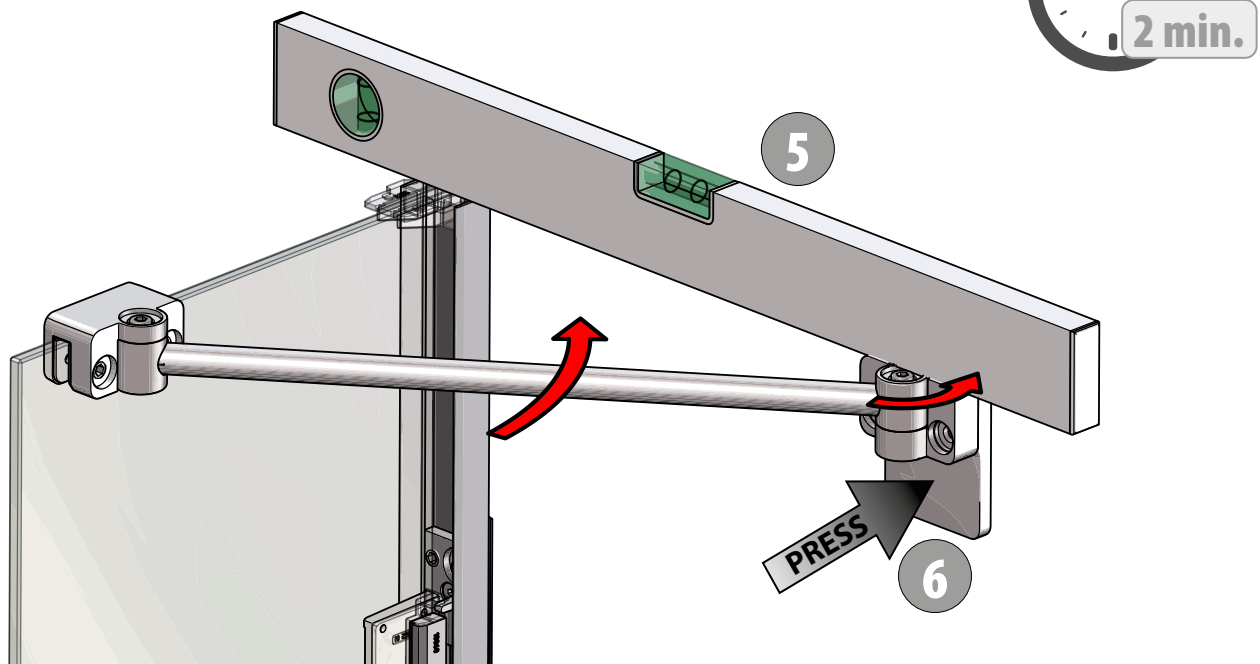
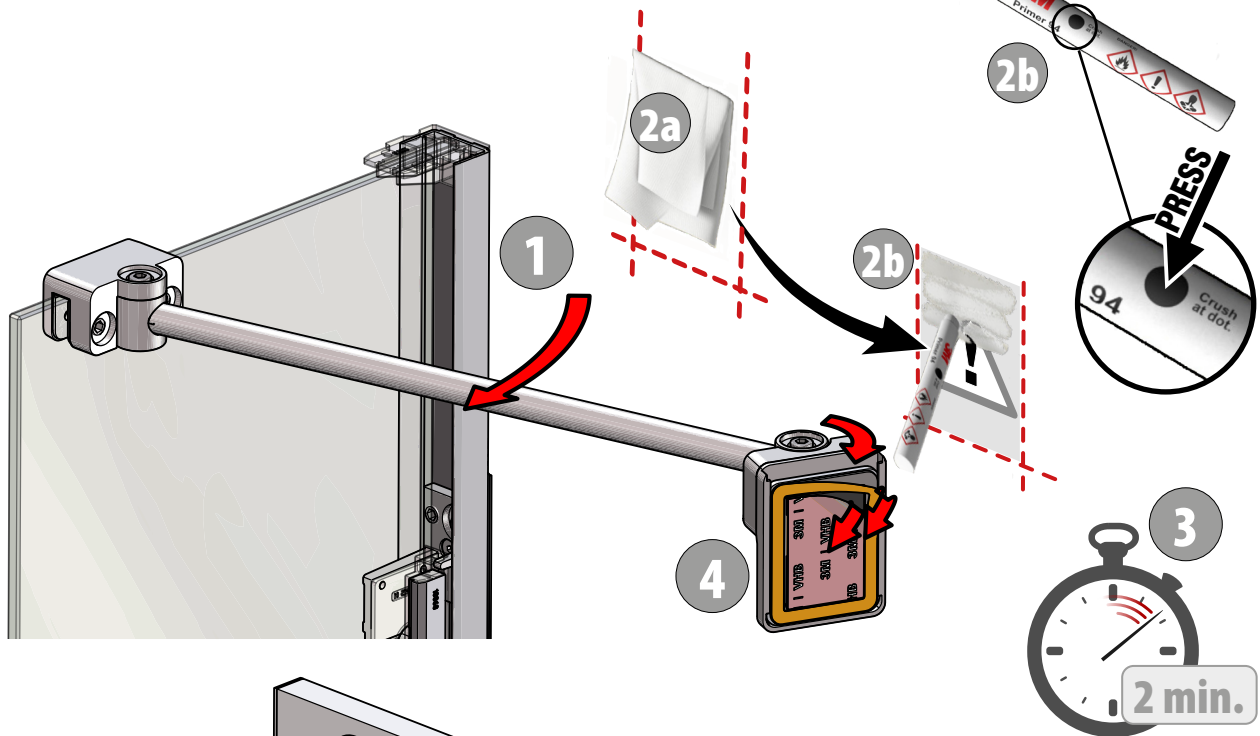
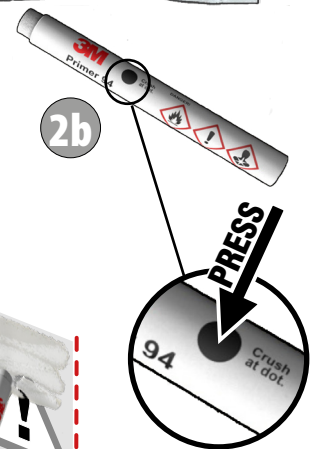
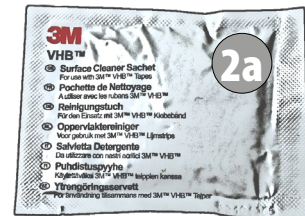

14

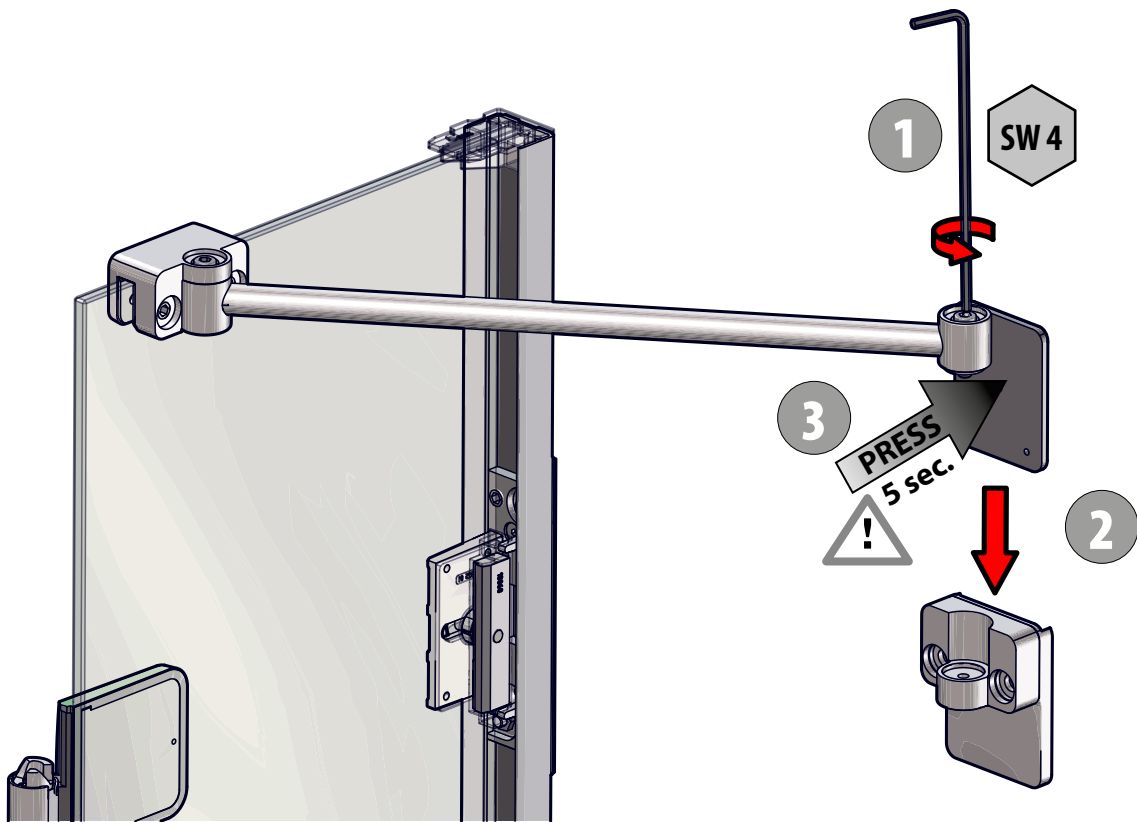

15

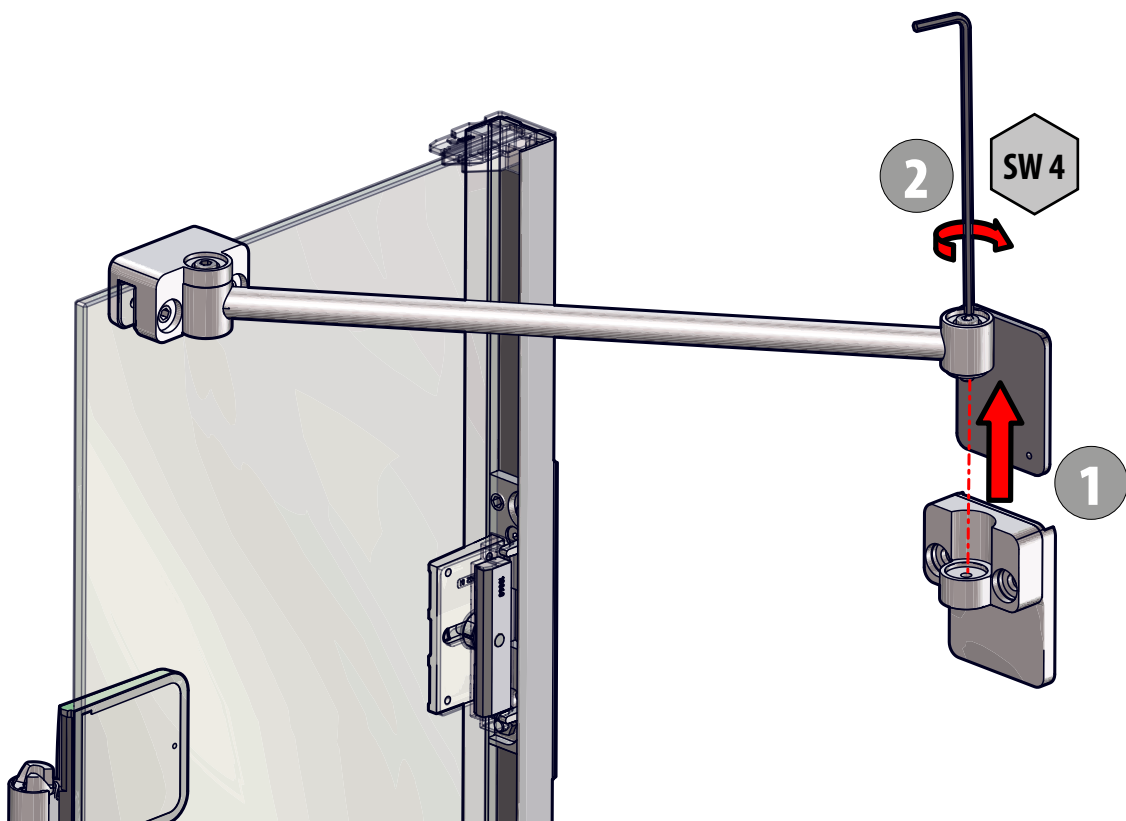

16

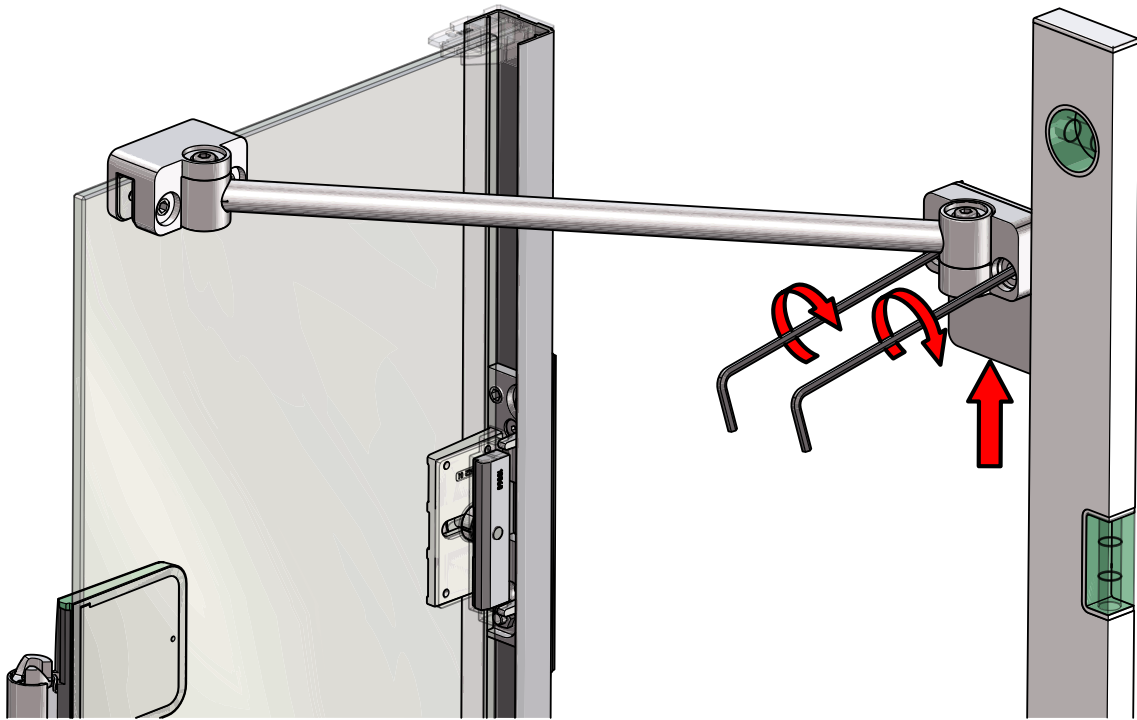

17

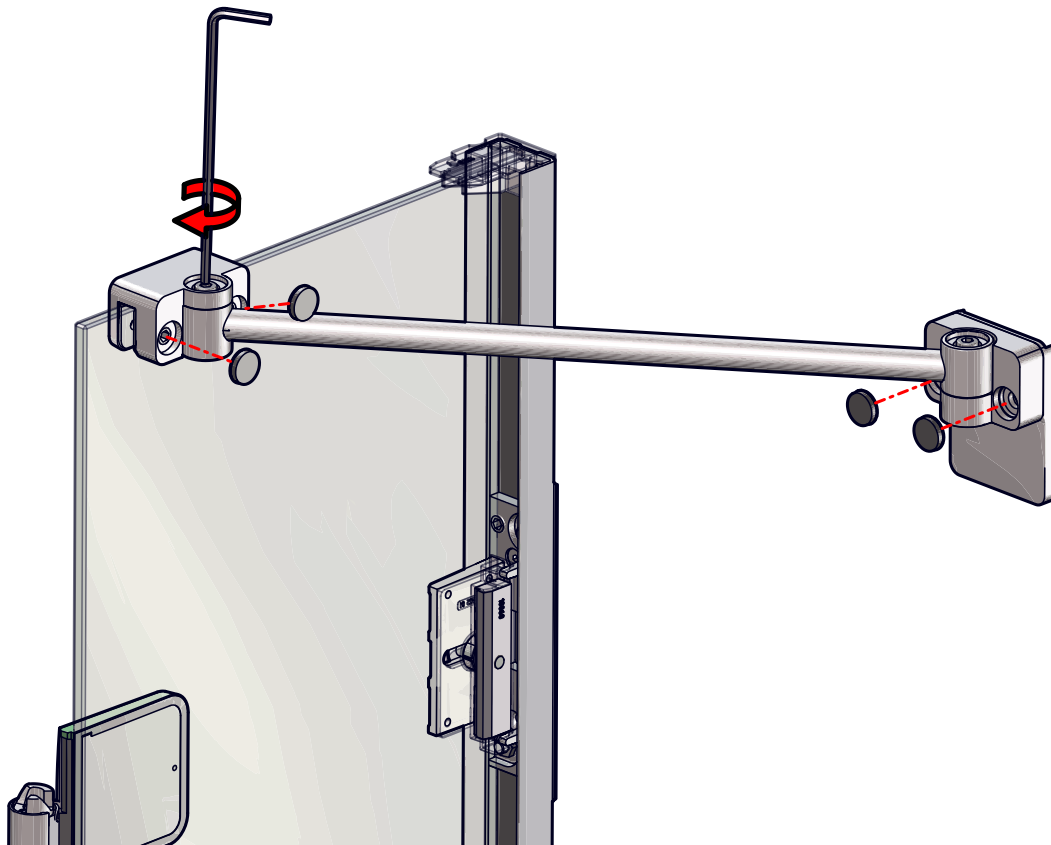

18

innen  
inside  
intérieur  
binnenkant  
lato interno

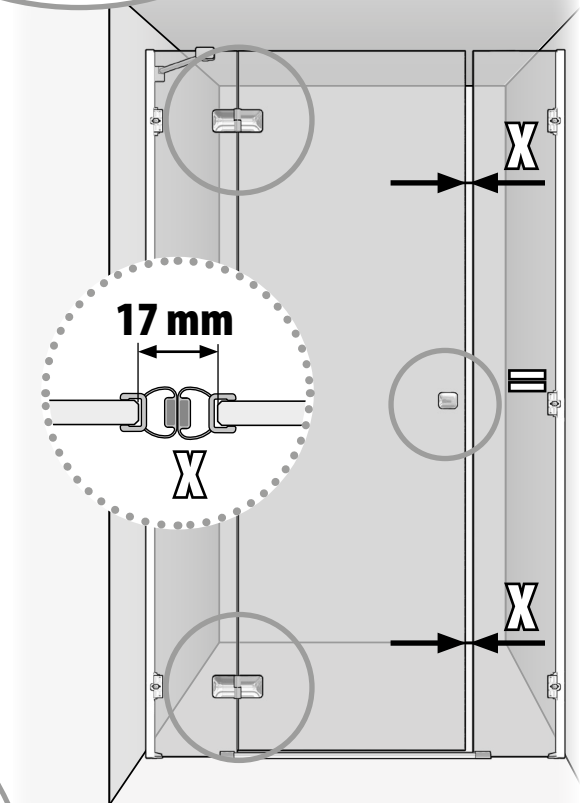
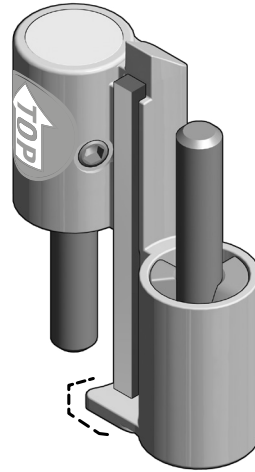
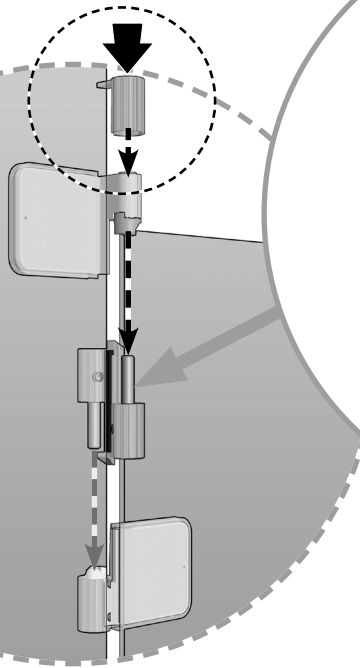

17 mm

X

X

X

innen  
inside  
intérieur  
binnenkant

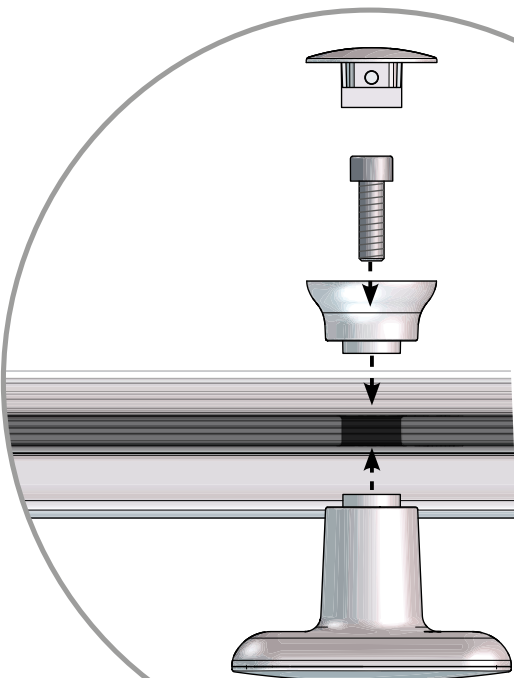

2x

M5 x 25mm

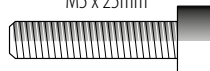

OPTIONAL	OPTIONAL	EN OPTION	OPTIONEEL
----------	----------	-----------	-----------

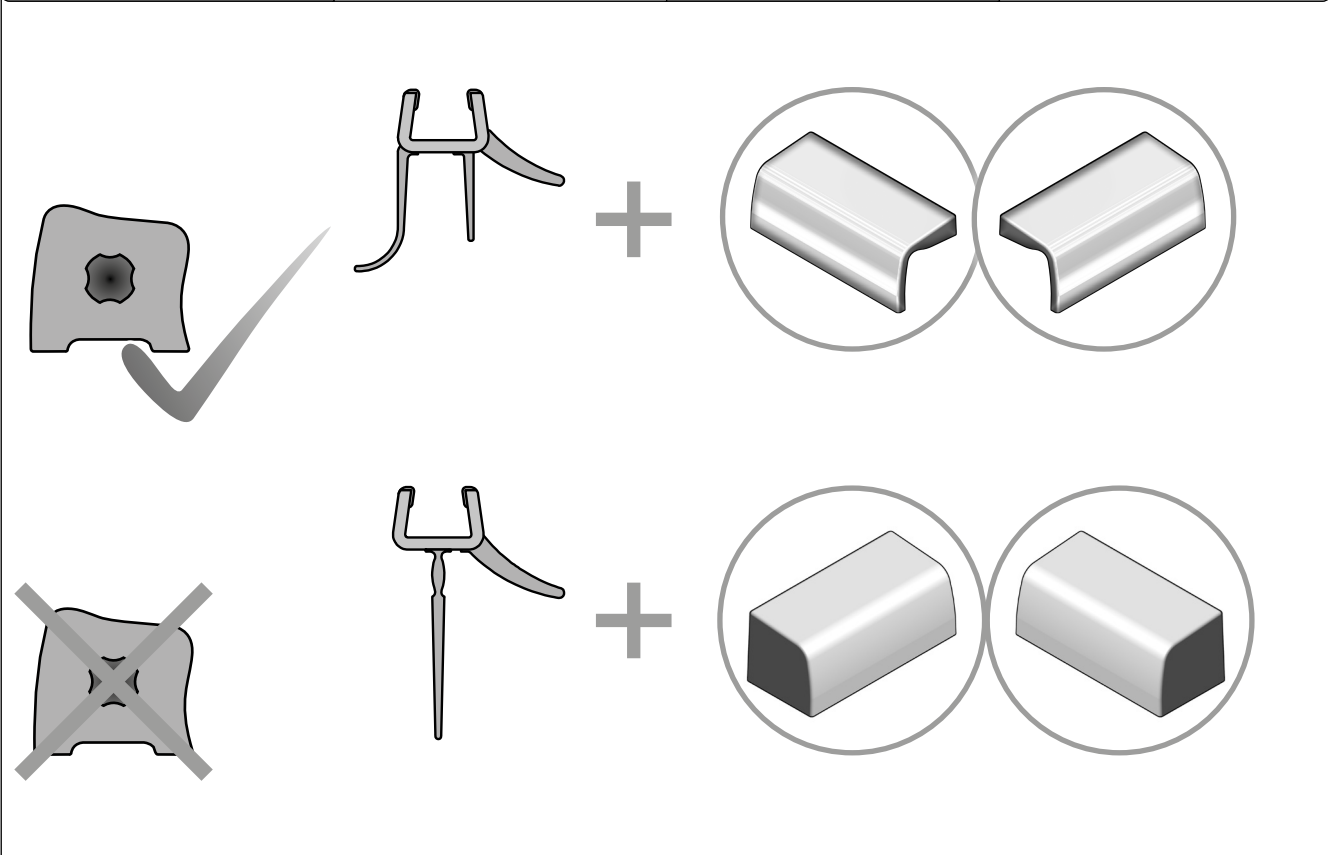

**DE** Der Hersteller weist an dieser Stelle ausdrücklich darauf hin, dass die Montage der im Lieferumfang enthaltenen Schwalleiste zur Erreichung der Dichtheitsanforderungen nach Norm (DIN 14428) erforderlich ist. Wird auf die Schwalleiste verzichtet, übernimmt der Hersteller keinerlei Haftung für daraus resultierende Schäden.

Eine spätere Montage der Schwalleiste ist ohne bauliche Veränderungen an der Duschahtrennung möglich. Für diesen Fall bitte das nicht verwendete Montagematerial dem Endkunden zur Aufbewahrung übergeben.

**EN** At this stage the manufacturer makes a point of expressly informing you that mounting of the solid sealing strip delivered is necessary to achieve the degree of sealing required under the standard DIN 14428.

If you dispense with the sealing strip, the manufacturer accepts no liability whatsoever for resulting damages.

It is possible to mount the surge strip at a later date without any changes to the shower side wall. In this case please hand over the unused fixation materials to the customer for storage.

**FR** A cet endroit, le fabricant indique expressément que le montage de la baguette de refoulement est indispensable pour obtenir l'étanchéité requise par la Norme (DIN 14428). Si toutefois cette baguette de refoulement n'est pas installée, le fabricant ne peut, en aucun cas, être tenu pour responsable des dégâts qui en résulteraient.

Le montage de la baguette de refoulement est toujours possible sans modification de la cabine de douche. Dans ce cas merci de remettre le matériel de montage non utilisé au client final pour le conserver.

**NL** De producent maakt u er op dit punt op attent, dat de montage van de in de levering opgenomen spatrand nodig is om aan de dichtheidseisen naar norm DIN 14428 te voldoen. Wanneer u afziet van montage van de spatrand, is de producent niet aansprakelijk voor eventuele daaruit vloeiende schade.

Een latere montage van de spatrand is mogelijk zonder dat een bouwkundige verandering van de doucheafdeling nodig is. In dit geval het niet het gebruikte montagemateriaal aan de eindklant geven om te bewaren.

19

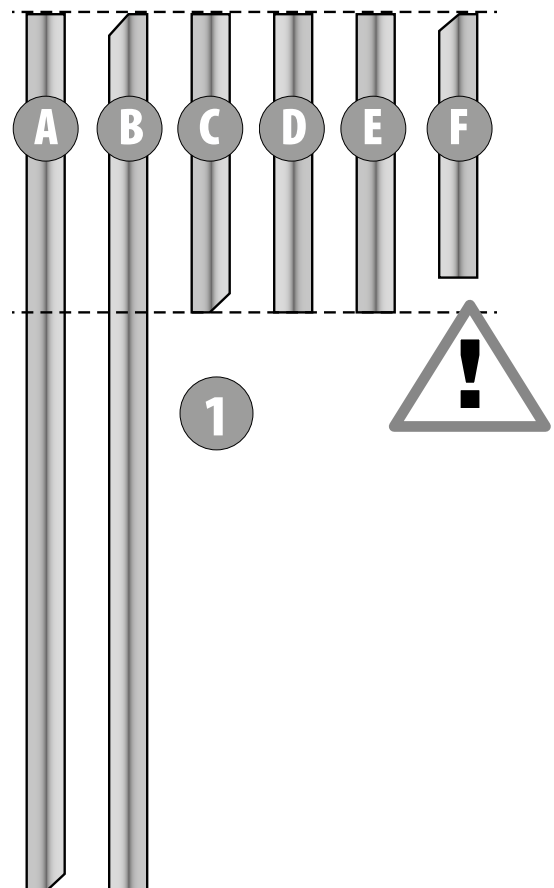
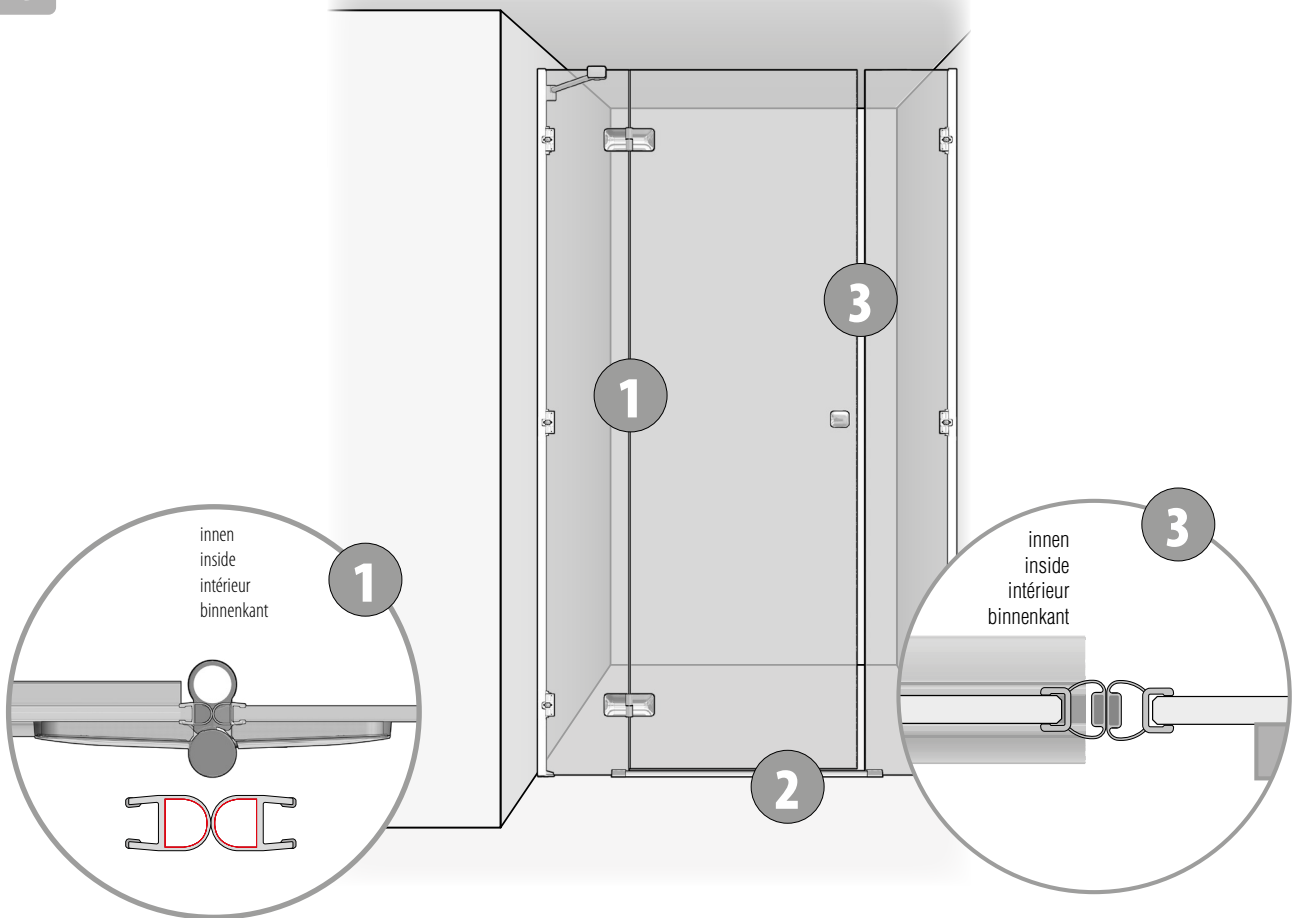



20

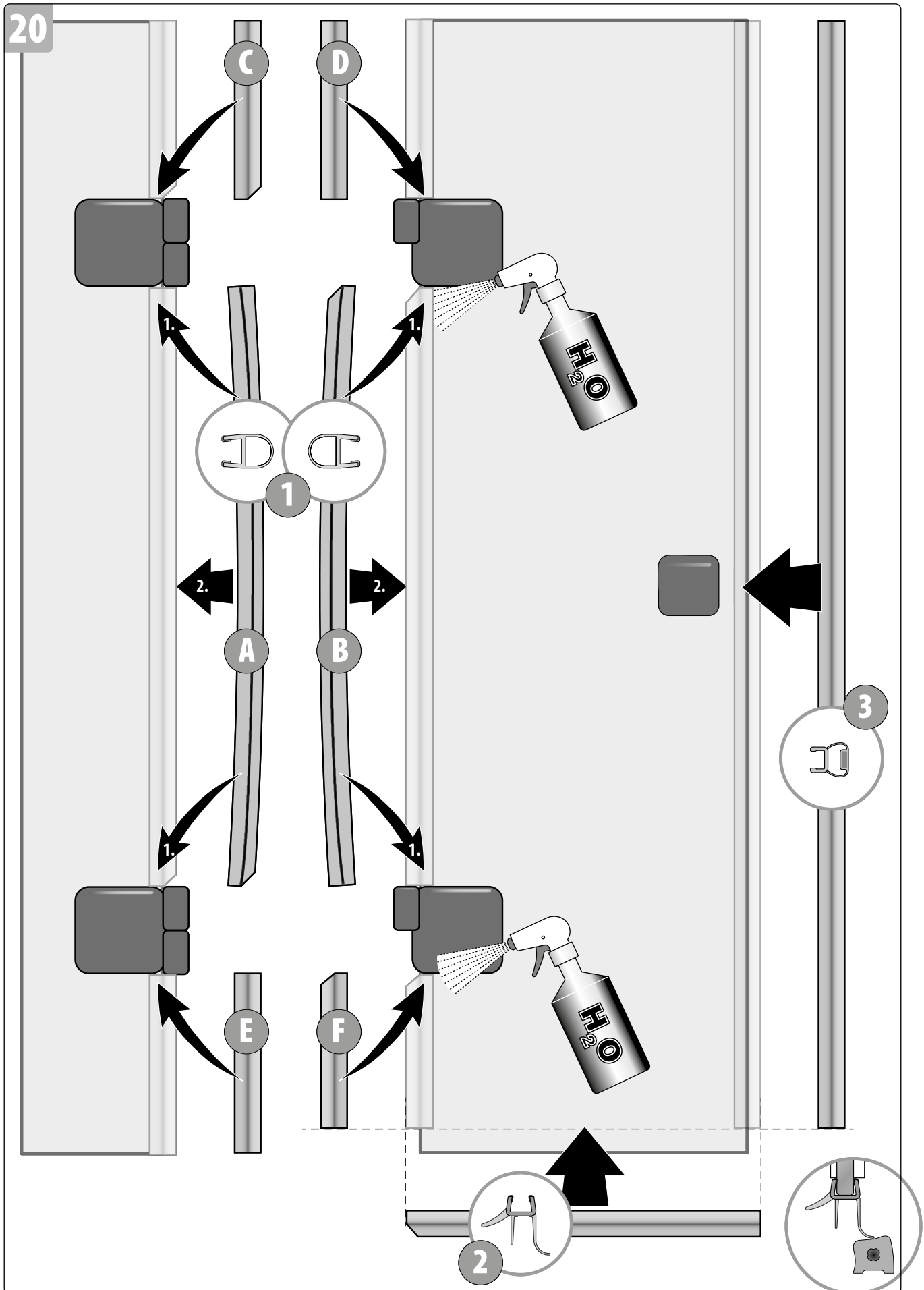

21

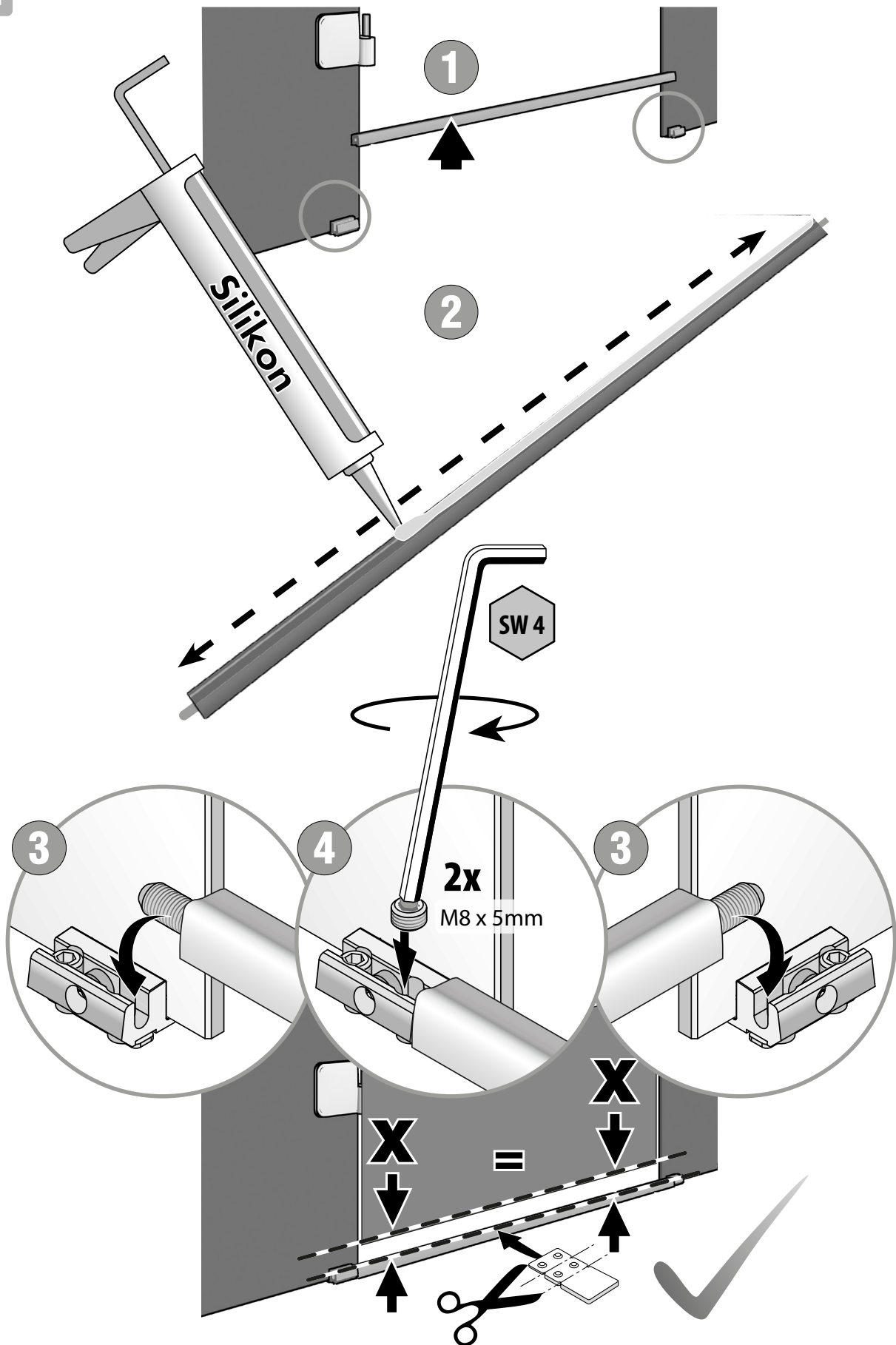

22

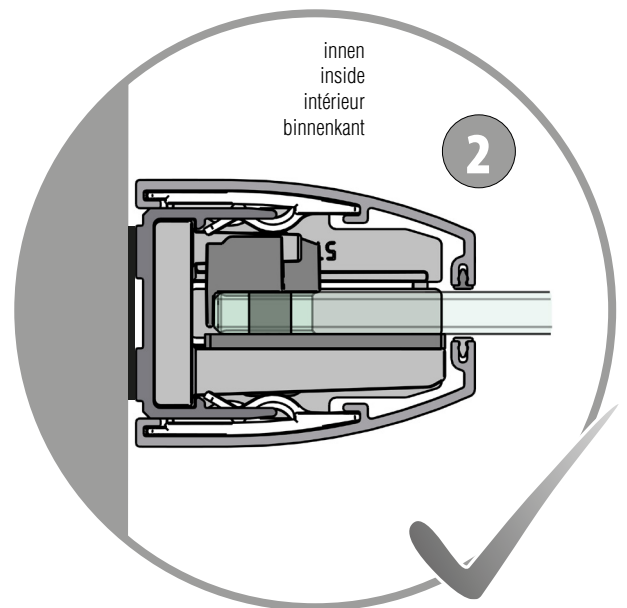
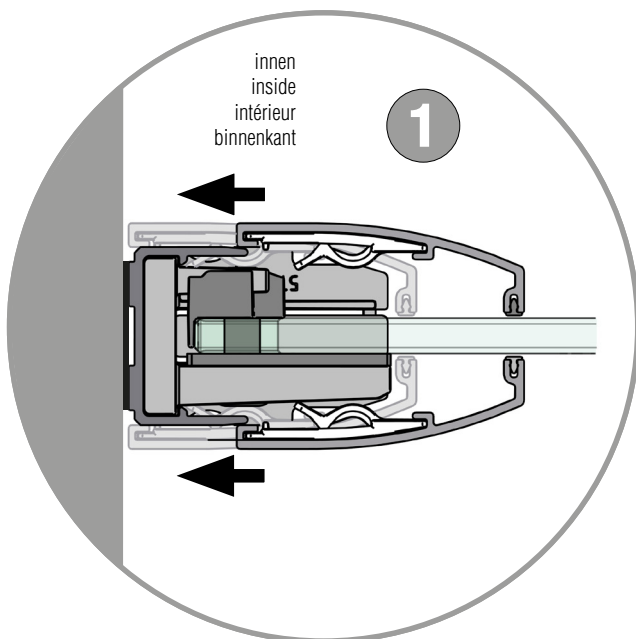
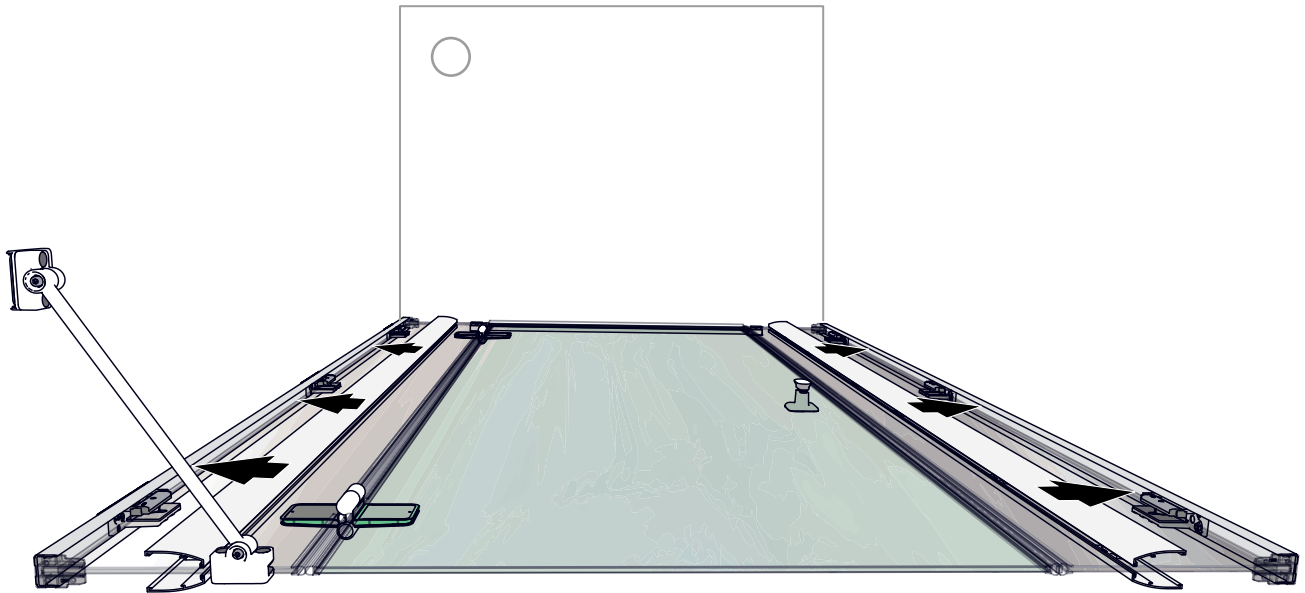

23

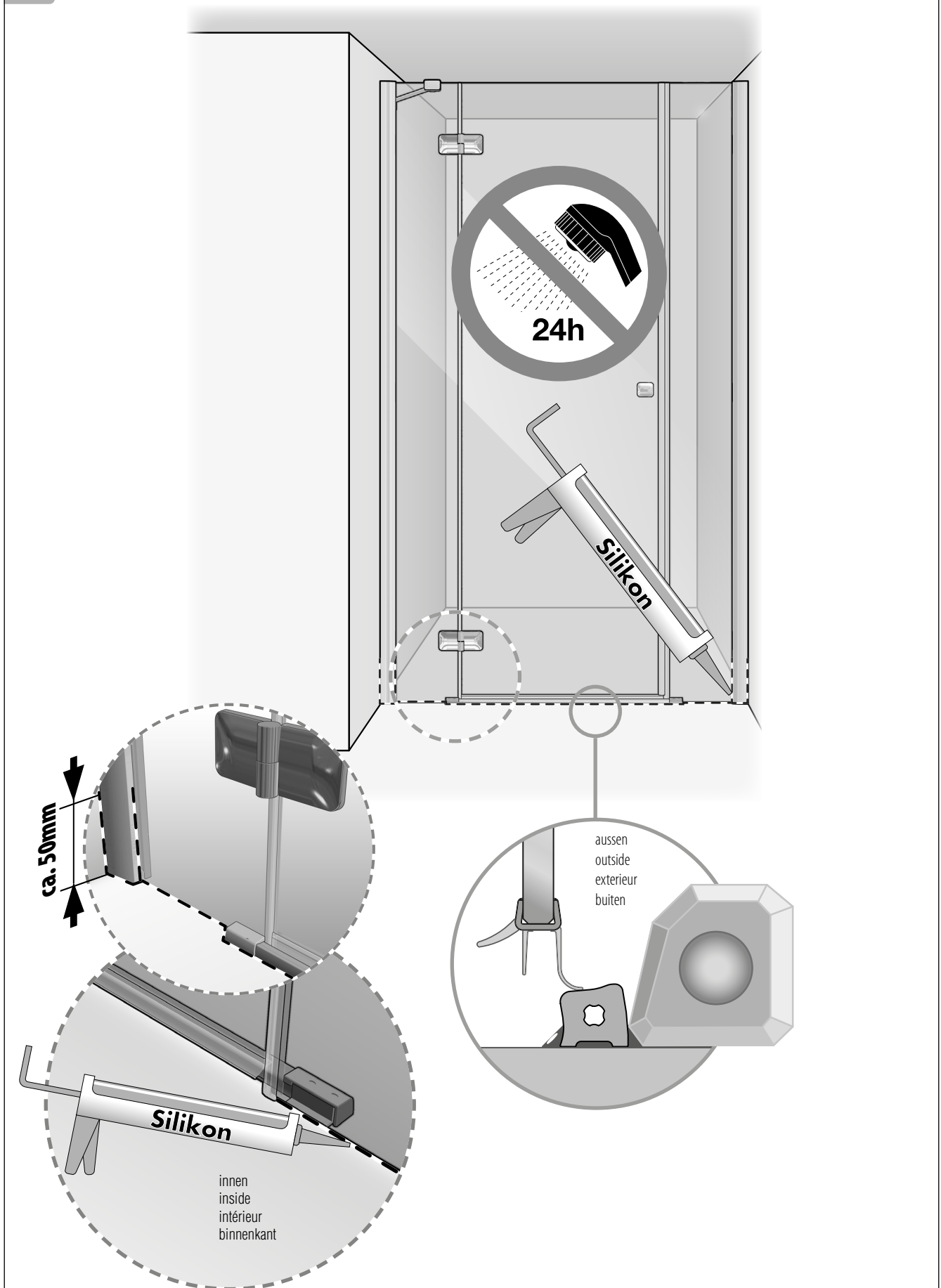

24

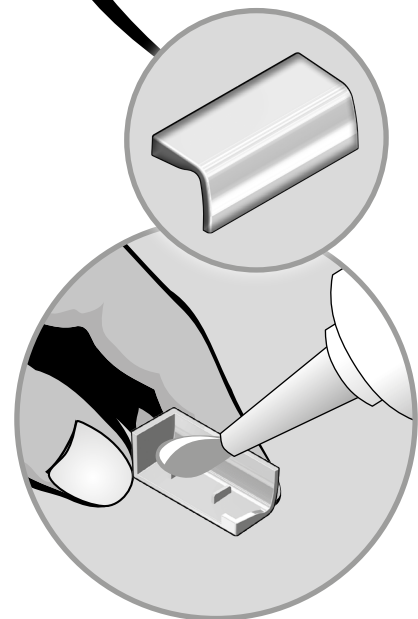
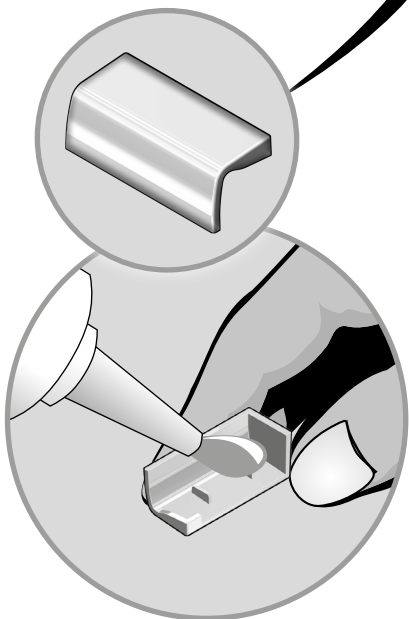
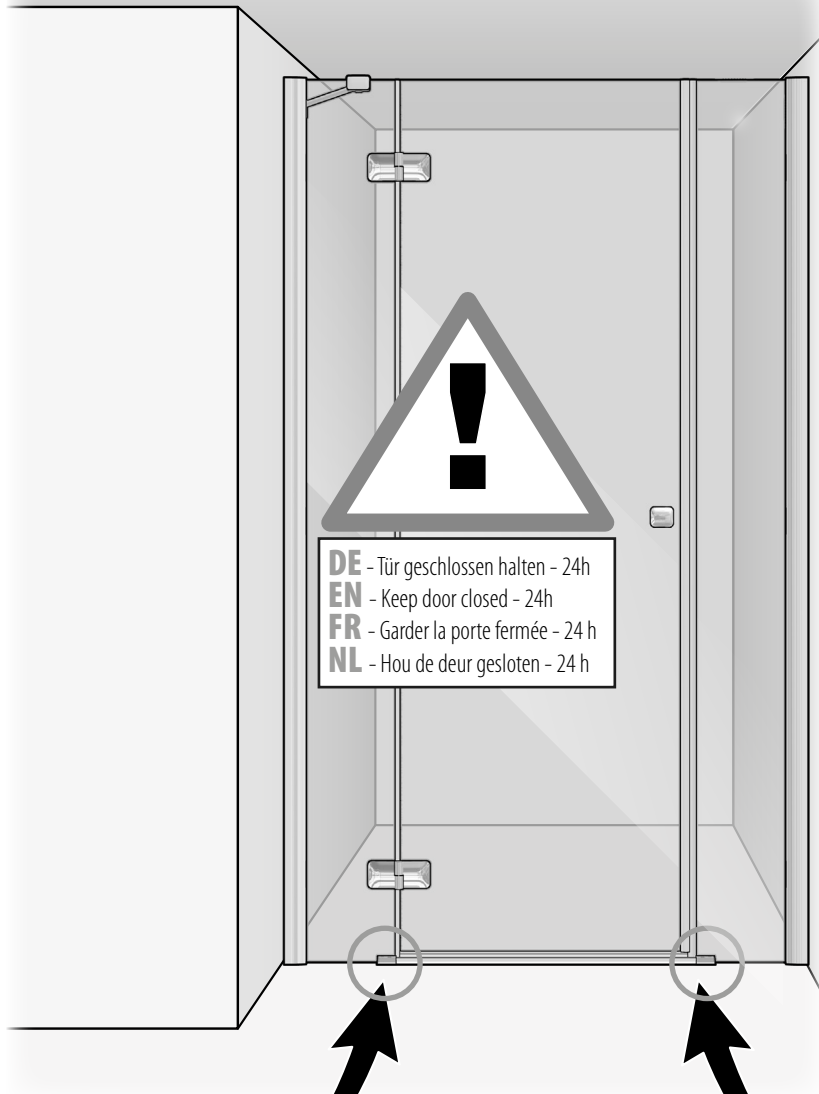

## Pendeltür an Fixteil in Nische extrabreit, 1 Türteil und 2 Fixteile

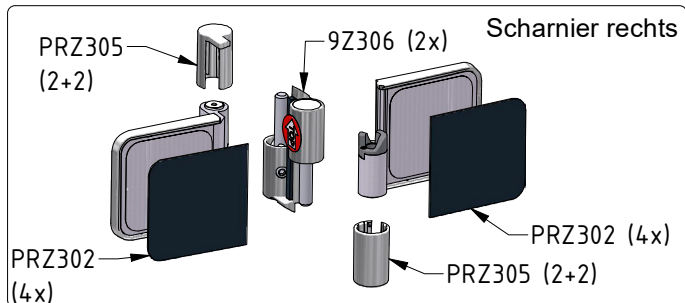
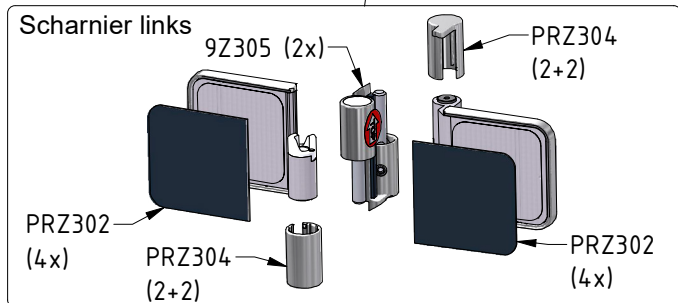
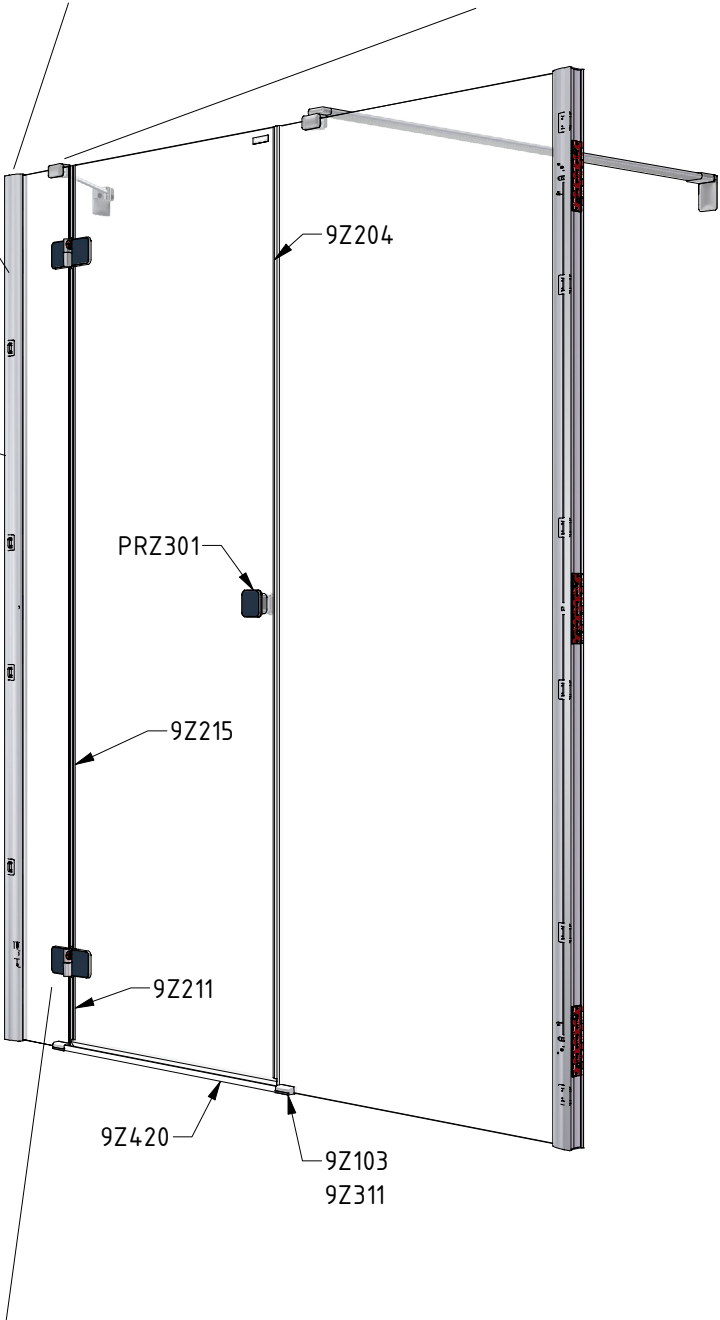
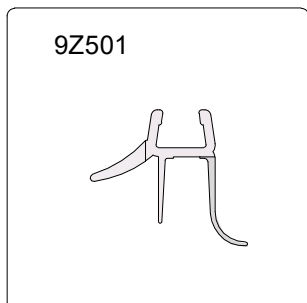
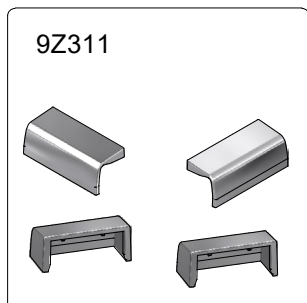
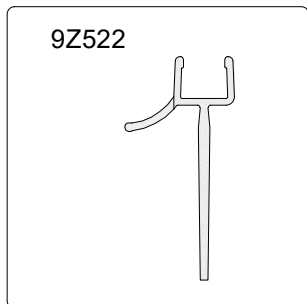
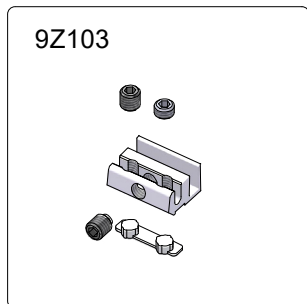
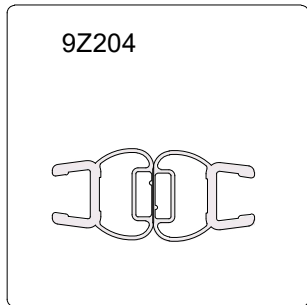
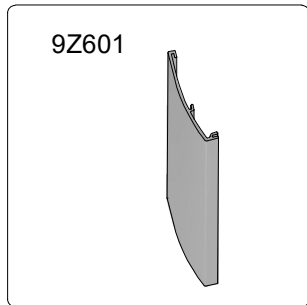
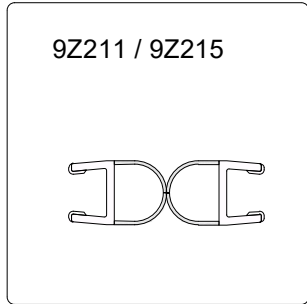
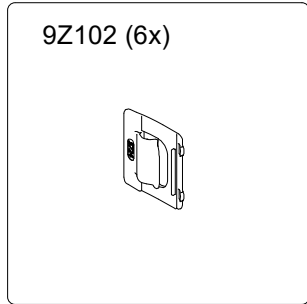
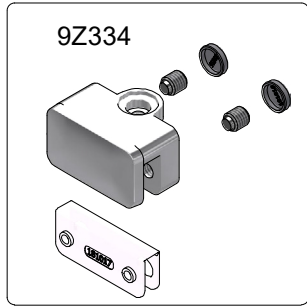
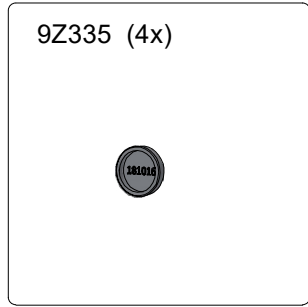
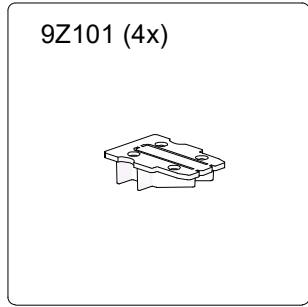
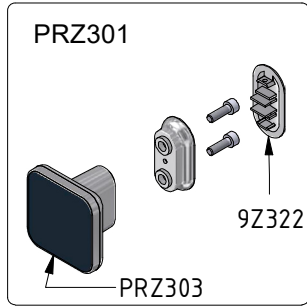



Artweger GmbH. & Co. KG  
Sulzbacherstraße 60 | 4820 Bad Ischl | Austria  
Tel. +43 6132 205-0 | Fax +43 6132 205-5001  
info@artweger.at | www.artweger.at

Verkauf Deutschland  
Artweger GmbH. & Co. KG  
Postfach 1169 | 83402 Ainring | Deutschland  
Tel. 0800 1114442-0 | Fax 0800 1114442-5002  
info@artweger.de | www.artweger.de

Verkauf Schweiz  
Artweger GmbH. & Co. KG  
Postfach 16 | CH-4202 Duggingen  
Tel. + 41 61 751 90 91 | Fax + 41 61 751 63 54  
info@artweger.com | www.artweger.com



Druck- und Satzfehler sowie technische Änderungen vorbehalten.  
Typographical errors and technical changes reserved.  
Sous réserve d'erreurs d'impression ou de syntaxe ainsi que de modifications techniques.  
Drukfouten, maatwijzingen en technische veranderingen voorbehouden.  
Ci riserviamo errori di stampa e variazioni tecniche.