

MONTAGEANLEITUNG

Pendeltür mit kurzer Seitenwand

5 W 3 1 . H

5 W 3 2 . H

ASSEMBLY INSTRUCTIONS

Swing DOOR with shortened sidescreen

5 W 3 1 . 7

5 W 3 2 . 7

NOTICE DE MONTAGE

Porte battante avec une partie fixe plus courte

5 W 3 . 8 8

MONTAGEVOORSCHRIFT

Pendeldeur met korte zijwand



Vor Gebrauch sorgfältig lesen! Zum Nachschlagen und Aufbewahren dem Endkunden übergeben!

Read carefully before use! Hand over to the customer for looking up and storage!

Avant emploi lire soigneusement! Remettez le au client pour la recherche et le stockage!

Voordien gebruik zorgvuldig lezend! Overhandig de klant voor het kijken omhooggaand en opslag!

DEUTSCH
Originalsprache

ENGLISH
Translation

FRANCAIS
Traduction

NEDERLANDS
Vertaling

INHALTSVERZEICHNIS	OVERVIEW
INHALTSVERZEICHNIS2	OVERVIEW2
SICHERHEITS- HINWEISE4	SAFETY- INSTRUCTIONS4
BENÖTIGTES WERKZEUG6	NECESSARY TOOLS6
MONTAGESET7	ASSEMBLY KIT7
MONTAGE VARIANTEN8	ASSEMBLY VARIATIONS8
VERSTELLBEREICH8	ADJUSTMENT RANGE8
MONTAGE VARIANTEN9	ASSEMBLY VARIATIONS9
WANNEN EINBAUMASS9	TRAY INSTALLATION MEASUREMENT9
MONTAGE10	ASSEMBLY10
» WANDANSCHLUSS10	» INSTALLATION OF IMMOVABLE ELEMENT10
» JUSTIEREN14	» ADJUST14
» MONTAGE STABILISATOR16	» INSTALLATION OF STABILIZER16
» TÜRTEIL19	» DOOR PART19
» GRIFF22	» HANDLE22
» MONTAGE DICHTLEISTEN22	» INSTALLATION OF SEALING STRIP22
OPTIONAL26	OPTIONAL26
» ABDICHTEN MIT SANITÄRSILIKON28	» SEALING WITH SANITARY SILICONE28
» MONTAGE DICHTLEISTEN29	» INSTALLATION OF SEALING STRIP29
ERSATZTEILE30	SPARE PARTS30

Montageanleitung für Einbau LINKS -
bei Einbau RECHTS–spiegelgleicher Aufbau.

Assembly instructions for installation LEFT -
for installation RIGHT–assemble in mirror image.

VUE D'ENSEMBLE	OVERZICHT
VUE D'ENSEMBLE3	OVERZICHT3
INSTRUCTIONS- SÉCURIT4	VEILIGHEIDS- VOORSCHRIFTEN4
OUTILLAGE NECESSAIRE6	BENODIGD GEREEDSCHAP6
SET DE MONTAGE7	MONTAGESET7
VARIANTES DE MONTAGE8	MONTAGE VARIANTEN8
POSITIONNEMENT8	VERSTELBAARHEID8
VARIANTES DE MONTAGE9	MONTAGE VARIANTEN9
MESURES POUR MON TAGE SUR RECEVEUR9	DOUCHEBAK INBOUWMAAT9
MONTAGE10	MONTAGE10
» MONTAGE PARTIE FIXE10	» MONTAGE VAST DEEL10
» AJUSTER14	» GOED AFSTELLEN14
» MONTAGE STABILISATEUR16	» MONTAGE STABILISATOR16
» ELÉMENT DE PORTE19	» DEURDEEL19
» POIGNÉE22	» GREEP22
» MONTAGE BAGUETTES D'ÉTANCHÉITÉ22	» MONTAGE AFDICHTINGEN22
EN OPTION26	OPTIONEEL26
» ETANCHER AVEC DU SILICONE SANITAIRE28	» AFDICHTEN MET SANITAIR-SILICONEN28
» MONTAGE BAGUETTES D'ÉTANCHÉITÉ29	» MONTAGE AFDICHTINGEN29
PIÈCES DÉTACHÉES30	ONDERDELEN30

C'est prévue pour une installation à GAUCHE –
en cas d'une installation à DROITE –A inverser pour partie fixe en GAUCHE.

Montagevoorschrift voor inbouw LINKS -
bij inbouw RECHTS –montage in spiegelbeeld.

SICHERHEITS- HINWEISE

SAFETY- INSTRUCTIONS

INSTRUCTIONS- SÉCURITÉ

VEILIGHEIDS- VOORSCHRIFTEN

DE Vor dem Einbau bitte unbedingt beachten!

- Produkt **vor dem Einbau**, auf Richtigkeit, Beschädigungen und das Zubehör auf Vollständigkeit **überprüfen**.
- **Bei sichtbarem Schaden Produkt keinesfalls einbauen!**
- **Beachten Sie beim Hantieren das teilweise hohe Gewicht und/oder die großen Abmessungen von Einzelteilen.**
- **Beachten Sie beim Bohren der Löcher, dass Sie keine Leitungen (Elektro, Gas, Wasser) beschädigen.**



Unsere Haftung beschränkt sich alleine auf unsere Produkte und kann daher nicht auf den Ein- und Ausbau ausgedehnt werden. Die Kosten für einen nachträglichen Aus- und Einbau eines Produkts und die damit verursachten Schäden sind **kein** Bestandteil der Garantie.

EN Please note carefully before installing

- Before installing, check for correctness and damage and the accessories for completeness.
- **Do not under any circumstances install product with visible damage!**
- **Take the great weight and/or the large dimensions into consideration when handling individual parts!**
- **When drilling holes do not damage hidden pipes and wiring.**

Our liability is limited to our products alone and therefore cannot be extended to installation and dismantling. Costs for subsequent dismantling and installation of a product and damage caused thereby are not part of the guarantee.

FR A respecter impérativement avant le Montage

- Avant le montage de vérifier qu'il s'agit du bon modèle, qu'elle n'est pas endommagée et que les accessoires sont complets.
- **En cas de dommages visibles, ne pas monter le produit!**
- **Lors de la manutention, merci de prêter attention au poids parfois très élevé et/ou aux dimensions de certaines pièces!**
- **Faites attention en perçant les trous de ne pas endommager les tuyauteries (cables électriques, canalisations de gaz, d'eau, etc).**

Notre responsabilité se limite à nos produits et ne peut être étendue sur l'installation et le démontage. Les coûts générés lors d'un démontage après installation et d'une ré-installation d'un produit et les dommages qui en résultent ne pourront être pris en charge par la garantie.

NL Voor inbouw beslist in acht nemen!

- Bad voor het inbouwen op juistheid, beschadigingen en toebehoren op volledigheid controleren.
- **Bij zichtbare beschadiging product in geen geval inbouwen!**
- **Let u bij het gebruik om het gedeeltelijk grote gewicht en/of de grote afmetingen van enkele onderdelen!**
- **bij het boren van gaten er op letten, dat U geen leidingen (elektro, gas of water) beschadigt!**

Wanneer het bad betegeld wordt, beslist de inbouwmaten van de badkuip en van de doucheafscheiding in acht nemen. Onze aansprakelijkheid is beperkt tot onze producten en kan daarom niet op de in- en uitbouw uitgebreid worden. De kosten voor een latere uit- en inbouw van een product en de daaruit voortvloeiende schade zijn geen onderdeel van de garantie.



DE ACHTUNG!
Beim Hantieren
mit Glas Schutz-
kleidung tragen!

Bitte untersuchen Sie nach dem Auspacken das Einscheiben-Sicherheitsglas (ESG) unverzüglich auf mögliche Transportschäden, wie abgesprungene Kanten oder Ecken. Wird ein Schaden festgestellt bitte umgehend Schadensmeldung machen und die Scheibe nicht einbauen, da dieser Fehler auch später zu einem Bruch führen kann! Alle Gläser werden vor dem Verpacken sorgfältigst kontrolliert. Spätere Reklamationen, auch bei Bruch, können daher nicht anerkannt werden.

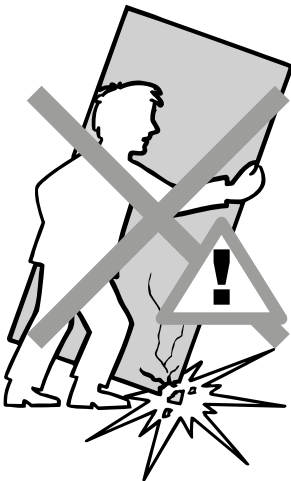

EN ATTENTION!
Wear protective
clothing when
handling glass!

Please examine the single-pane safety glass for possible transport damage such as chipped edges or corners immediately after unpacking. If damage is detected do not install the pane because a defect can lead to breakage later! Please make a damage report without delay! All glass panes are controlled with utmost care before packing. Therefore later complaints cannot be acknowledged, even in case of breakage.

FR ATTENTION !
Portez des
vêtements
protecteurs en
manipulant du
verre.

Merci de vérifier immédiatement le verre de sécurité monofeuille au déballage sur d'éventuels dommages survenus au transport, tels que chants et angles écaillés. Si toutefois un défaut a été constaté, merci d'en faire la déclaration au plus vite et ne pas monter la vitre, car ce défaut peut être, par la suite, à

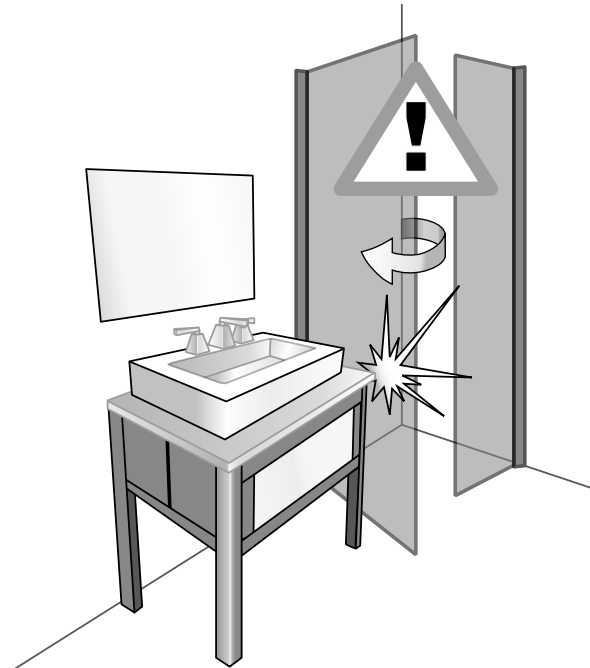

l'origine d'une casse! Tous les verres sont contrôlés minutieusement avant le conditionnement. Pour cette raison, aucune réclamation ultérieure, même en cas de casse, ne pourra être prise en compte.

Na het uitpakken het enkel veiligheidsglas (ESG) onmiddellijk op mogelijke transport- beschadigingen, zoals afgesprongen kanten of hoeken, controleren. Wordt een beschadiging vastgesteld, dan mag het glas niet worden ingebouwd, omdat deze schade ook later tot een breuk kan leiden !Bij een vastgestelde schade, meldt dit onmiddellijk! Al het glas wordt voor het verpakken zorgvuldig gecontroleerd. Latere reclames, ook bij breuk, kunnen daarom niet geaccepteerd worden.

NL ATTENTIE !
Bij het hanteren
van glas be-
schermde kle-
ding dragen!

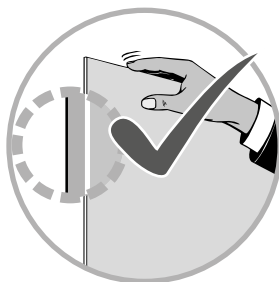









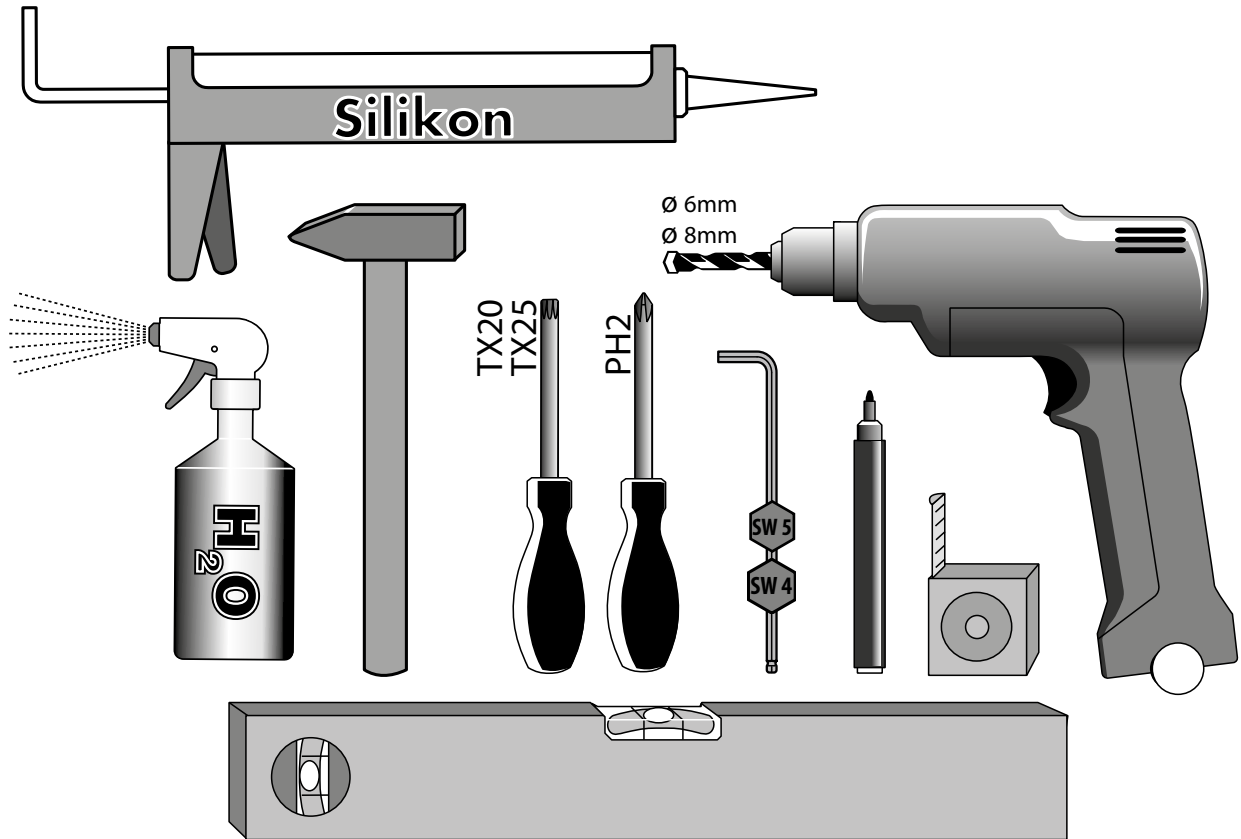



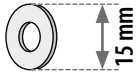







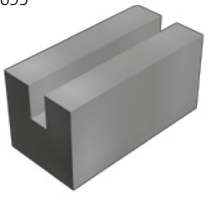
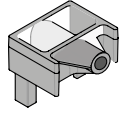

**BENÖTIGTES
WERKZEUG**

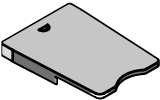
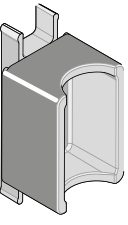
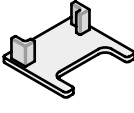
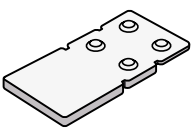
**NECESSARY
TOOLS**

**OUTILLAGE
NECESSAIRE**

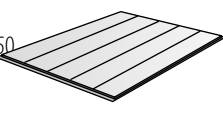
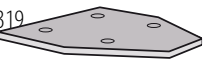
**BENODIGD
GEREEDSCHAP**

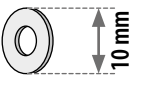

MONTAGESET	ASSEMBLY KIT	SET DE MONTAGE	MONTAGESET
9 x 4,8 x 60mm MatNr: 24466 	4 x DIN 9021-M5-A2 MatNr: 2494 	8 x Ø 8 x 50 mm MatNr: 24409 	3 x 3,5 x 25mm MatNr: 2418  2 x 4,2 x 38mm MatNr: 24467 
1x Ø3 mm MatNr: 18211 	2 x MatNr: 1881016 	5 x 3,5 x 13 mm MatNr: 2429  5 x MatNr: 18852 VC 	1x MatNr: 705739 
1x MatNr: 805W17  4cm	1x MatNr: 18853 	1x MatNr: 704209 DG 	1x MatNr: 704210 DG 
1x MatNr: 18926 VC 	1x MatNr: 704207 	4x MatNr: 704208 	1x MatNr: 704205 
2x MatNr: 704520 	1x MatNr: 18815 	1x MatNr: 18816 	1x MatNr: 704203 
10x MatNr: 10150  1x MatNr: 705319 	1x MatNr: 7042042  1x MatNr: 7042041 	2 x Ø 6 x 30 mm MatNr: 24410 	4 x DIN 125-M5-A2 MatNr: 2430 

MONTAGE VARIANTEN	ASSEMBLY VARIATIONS	VARIANTES DE MONTAGE	MONTAGE VARIANTEN
-------------------	---------------------	----------------------	-------------------

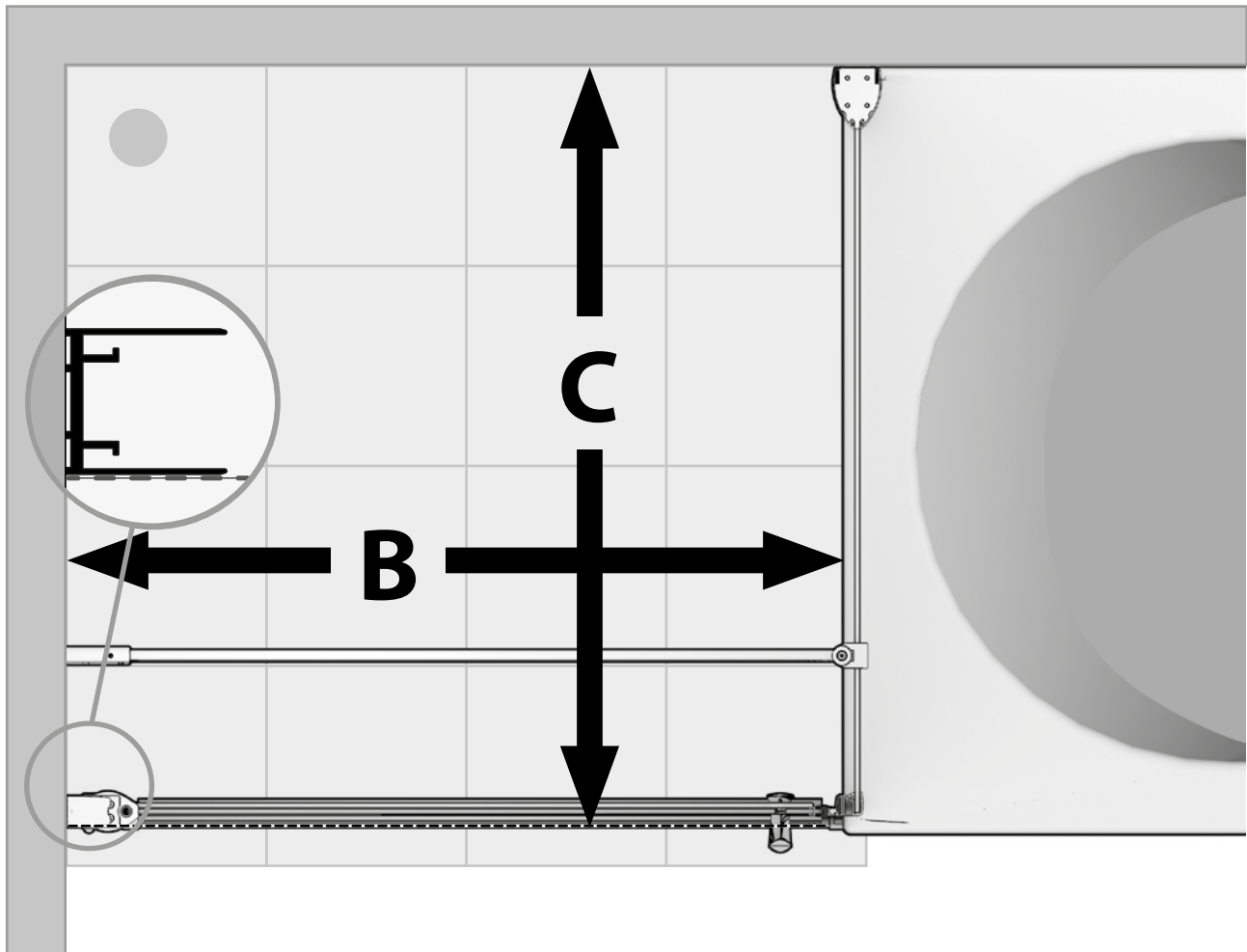

DE Montage ohne Duschwanne.

FR Montage sans receveur de douche.

EN Assembly without shower tray.

NL Montage zonder douchebak.

VERSTELLBEREICH	ADJUSTMENT RANGE	POSITIONNEMENT	VERSTELBAARHEID
-----------------	------------------	----------------	-----------------

Auftrag Nr.: /		Serie	B	C
Sondergrößen • special sizes • mesures spéciales • speciale maten		800x800	782 - 800 mm	766 - 784 mm
		900x900	882 - 900 mm	866 - 884 mm
B=	mm	C= siehe zusätzlichen Artikel • see additional article voir l'article supplémentaire • zie extra artikel	1000x1000	982 - 1000 mm
				966 - 984 mm

**MONTAGE
VARIANTEN**

**ASSEMBLY
VARIATIONS**

**VARIANTES
DE MONTAGE**

**MONTAGE
VARIANTEN**

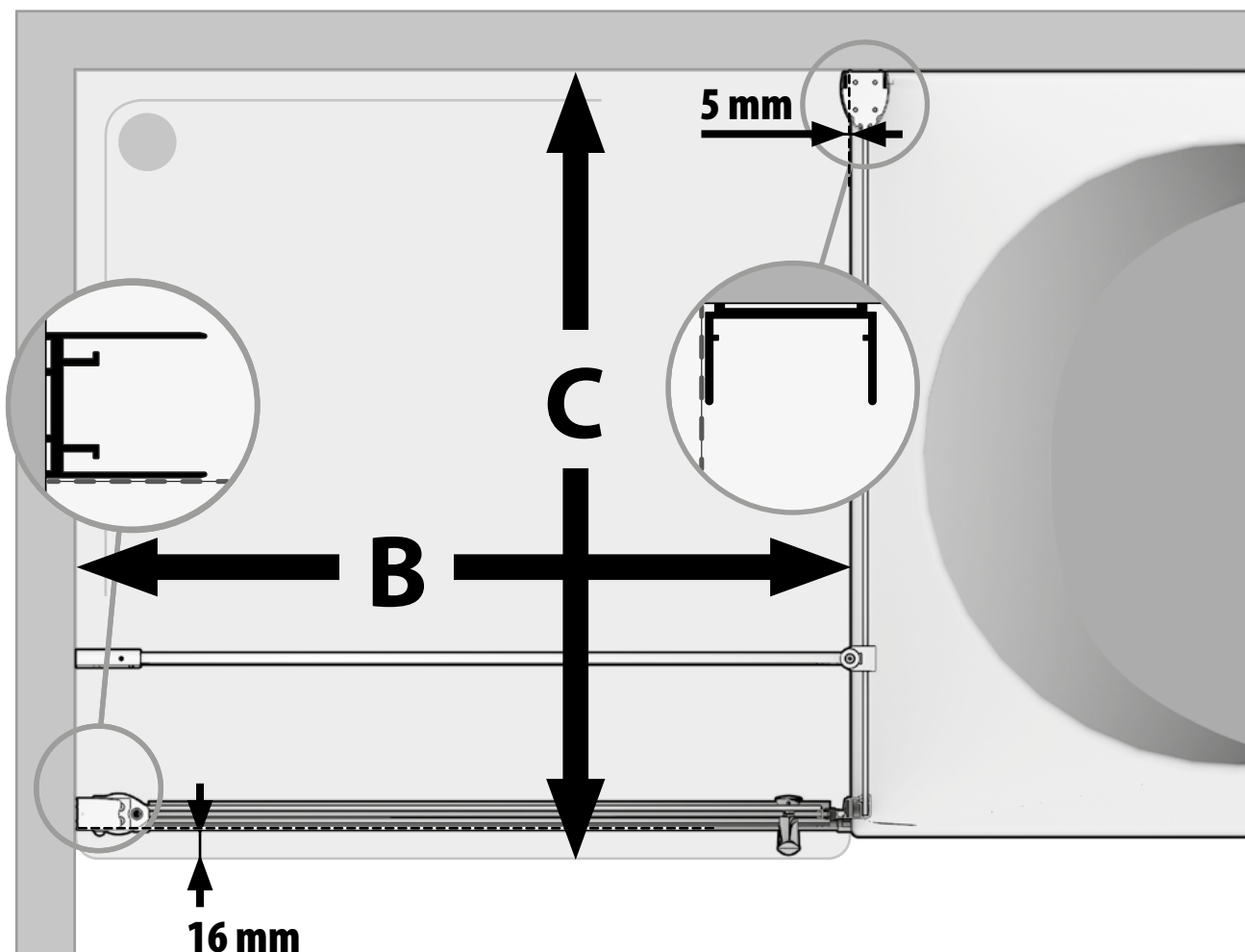

DE Montage auf Duschwanne.

FR Montage sur un receveur de douche.

EN Assembly on shower tray.

NL Montage op douchebak.

**WANNEN
EINBAUMASS**

**TRAY INSTALLATION
MEASUREMENT**

**MESURES POUR MON
TAGE SUR RECEVEUR**

**DOUCHEBAK
INBOUWMAAT**

Serie	B	C
800x800	782 - 800 mm	782 - 800 mm
900x900	882 - 900 mm	882 - 900 mm
1000x1000	982 - 1000 mm	982 - 1000 mm

1

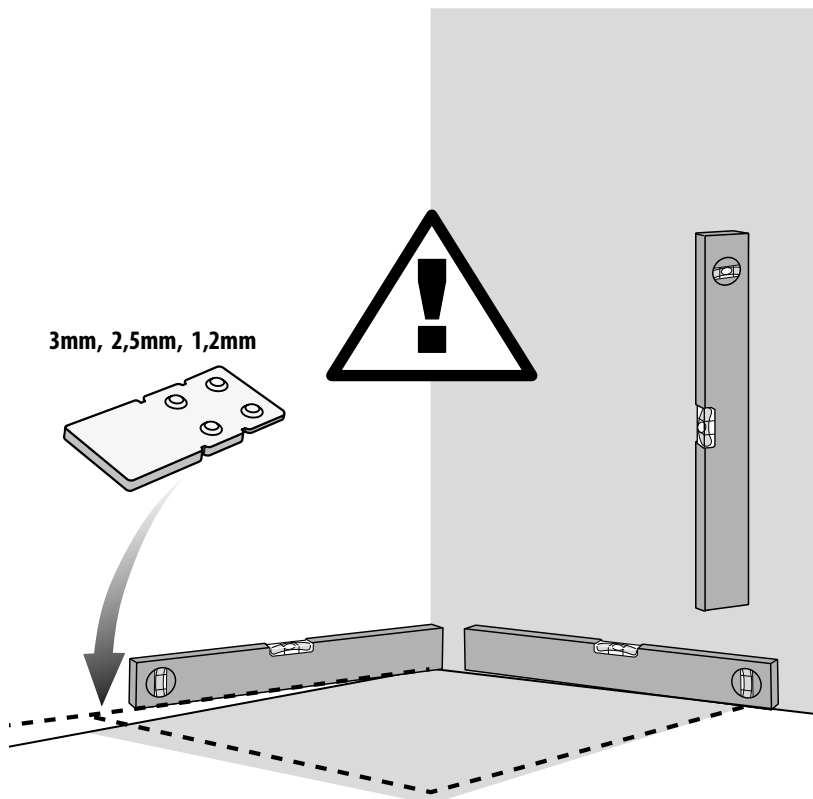

DE Achtung: Prüfen Sie vor Beginn der Montage die Größe Ihrer Duschtrennung

Eine **einwandfreie** Montage ist nur möglich wenn der Boden **waagrecht** und die Wände **senkrecht** sind.

EN Attention: Before assembly check the size of your shower enclosure

Correct installation is only possible if the floor is horizontal and the walls are vertical.

FR Attention: Avant de débiter le montage, contrôlez la dimension de votre paroi de douche

Un montage impeccable n'est possible que si le sol est parfaitement plan et le murs droits.

NL Let op: controleert u voor montage de grootte van uw douchekomb.

Een perfecte montage is alleen mogelijk, als de bodem horizontaal en de wanden verticaal t.o.v. elkaar staan.

2

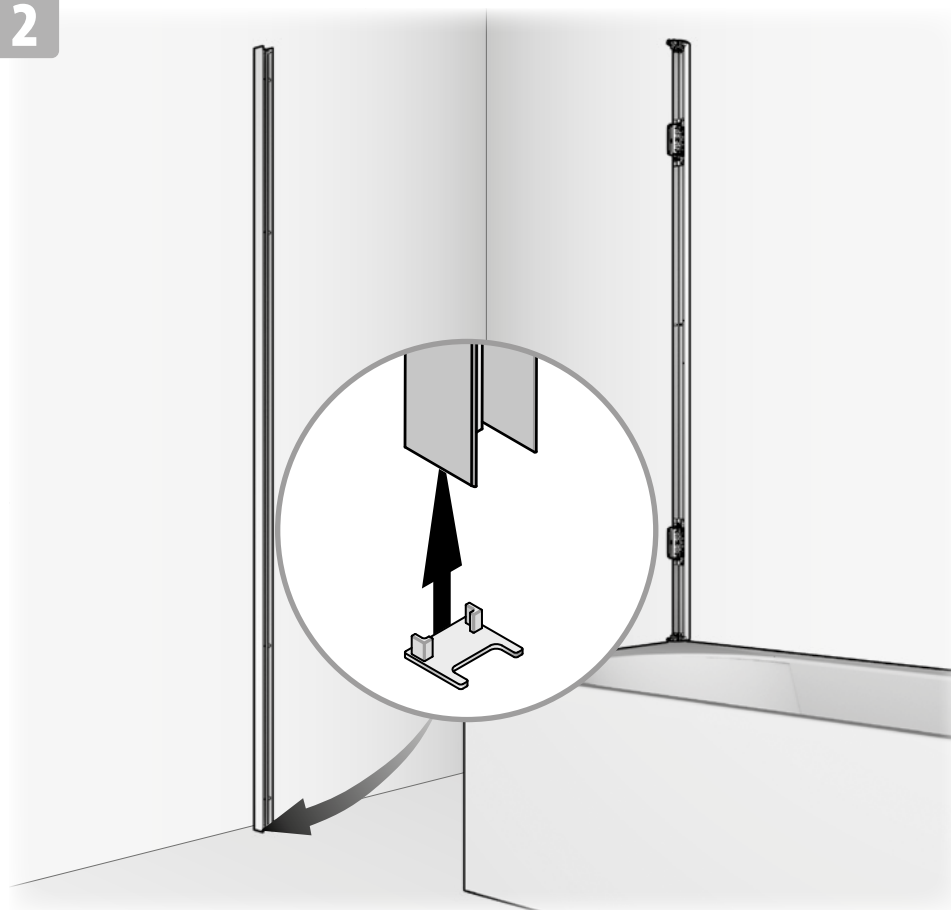

3

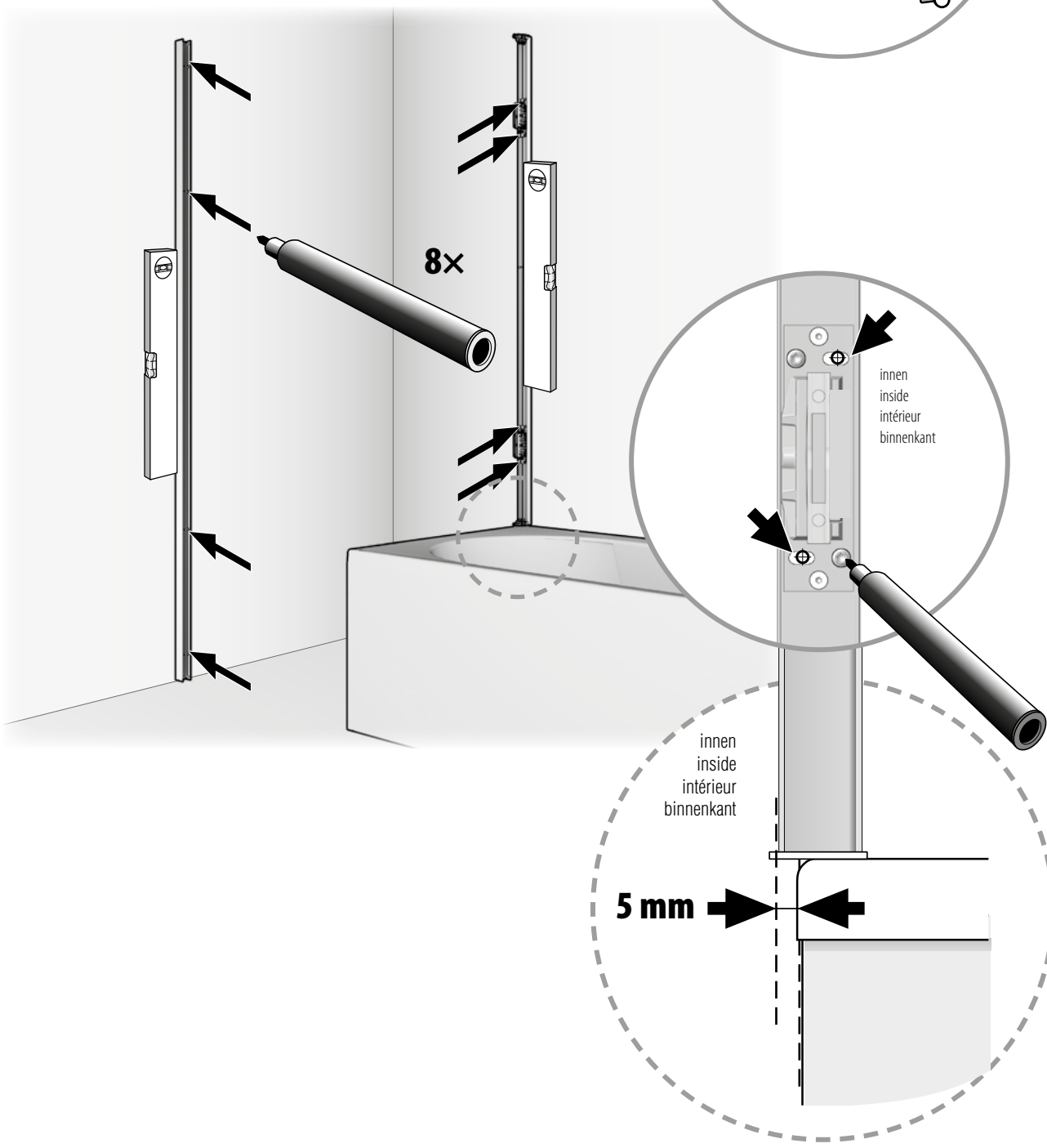
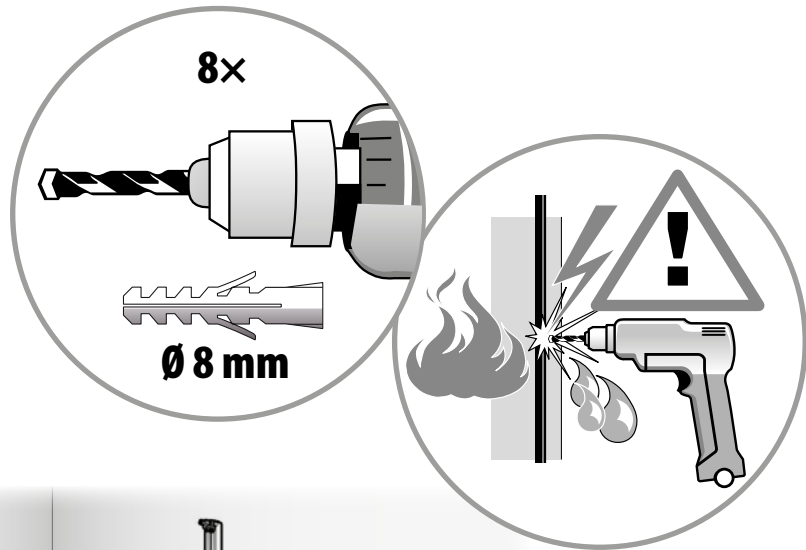

4

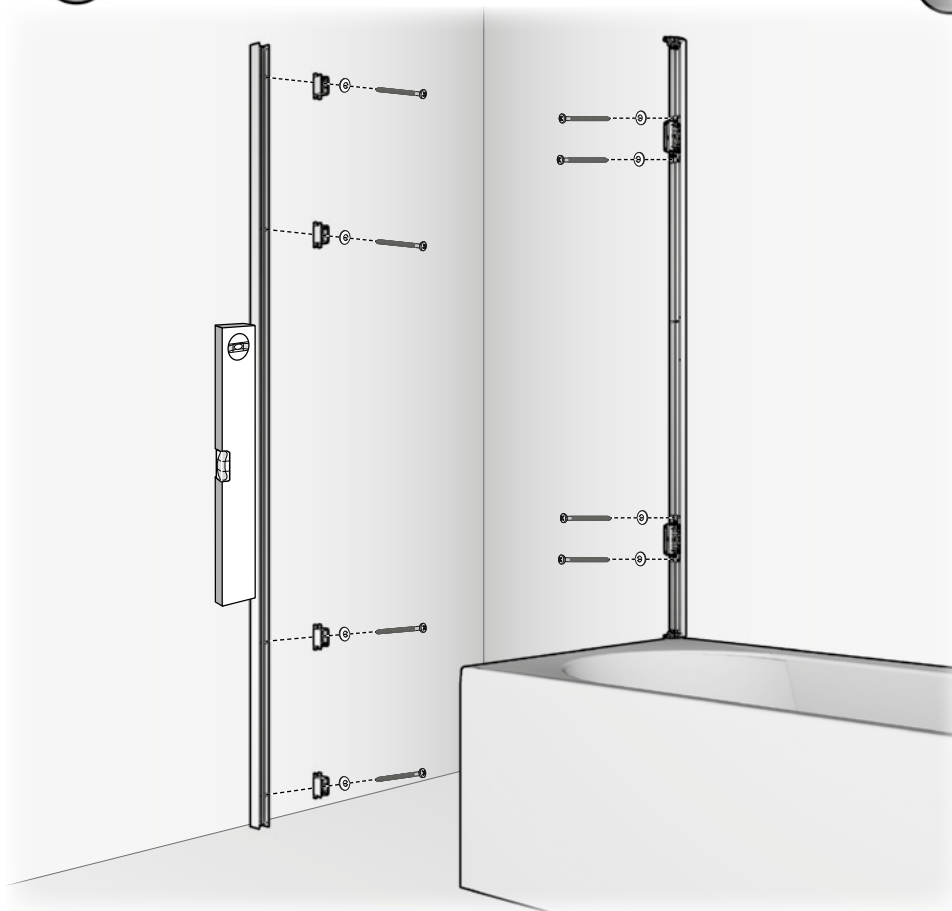
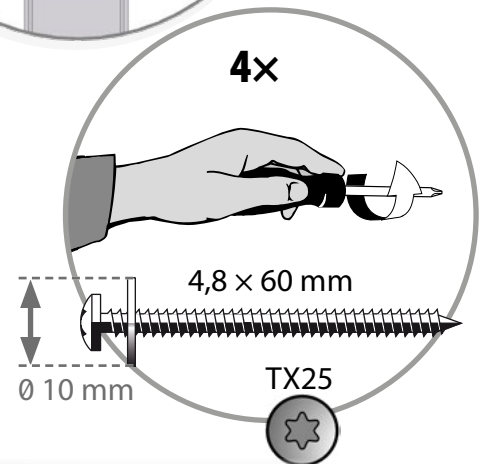
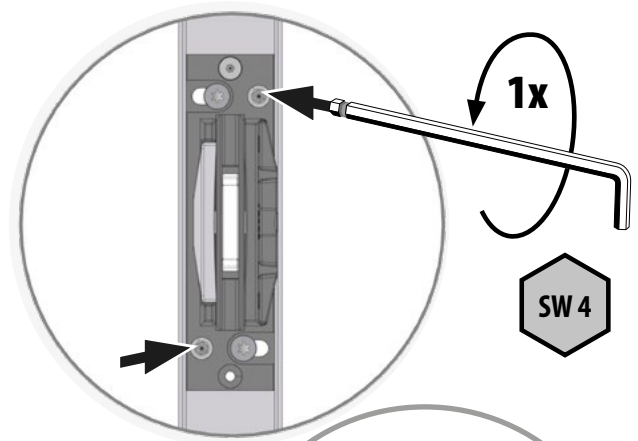
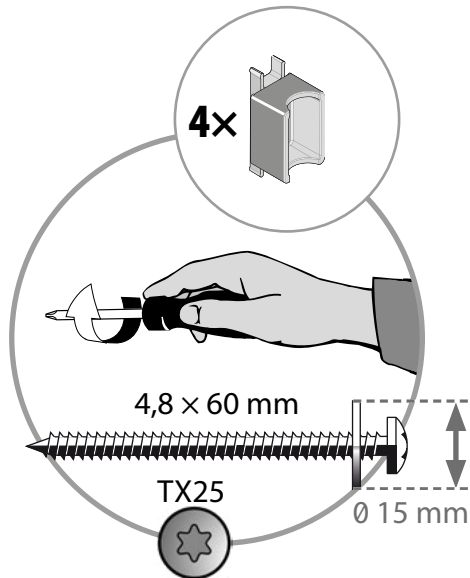

5

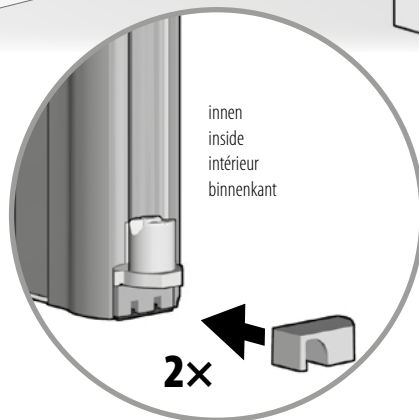
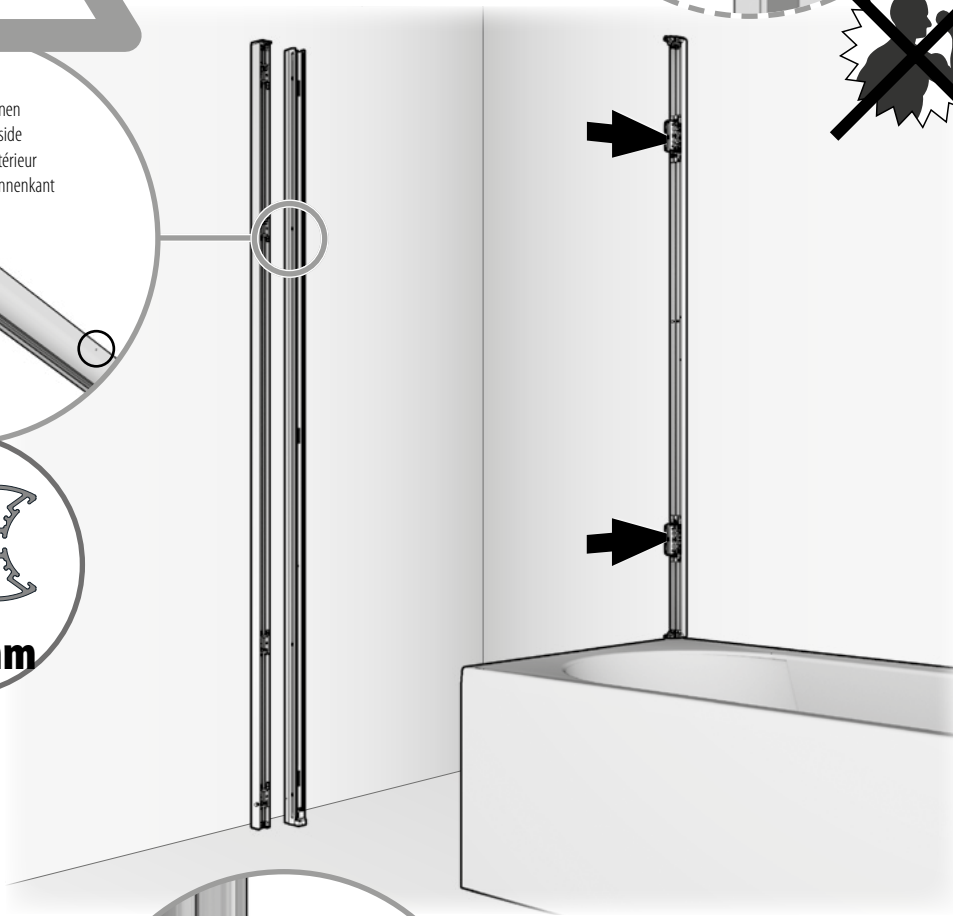
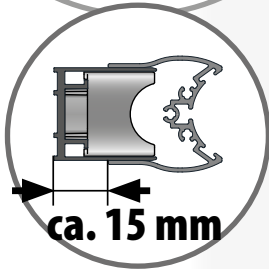
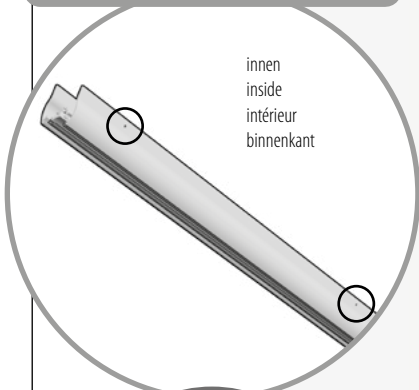
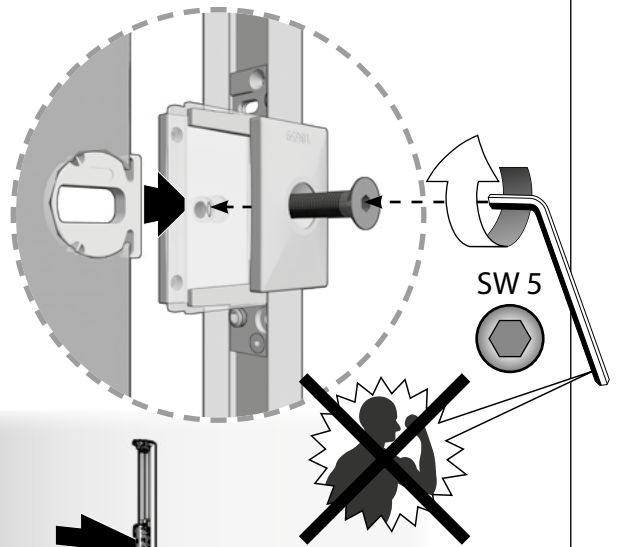

JUSTIEREN	ADJUST	AJUSTER	GOED AFSTELLEN
-----------	--------	---------	----------------

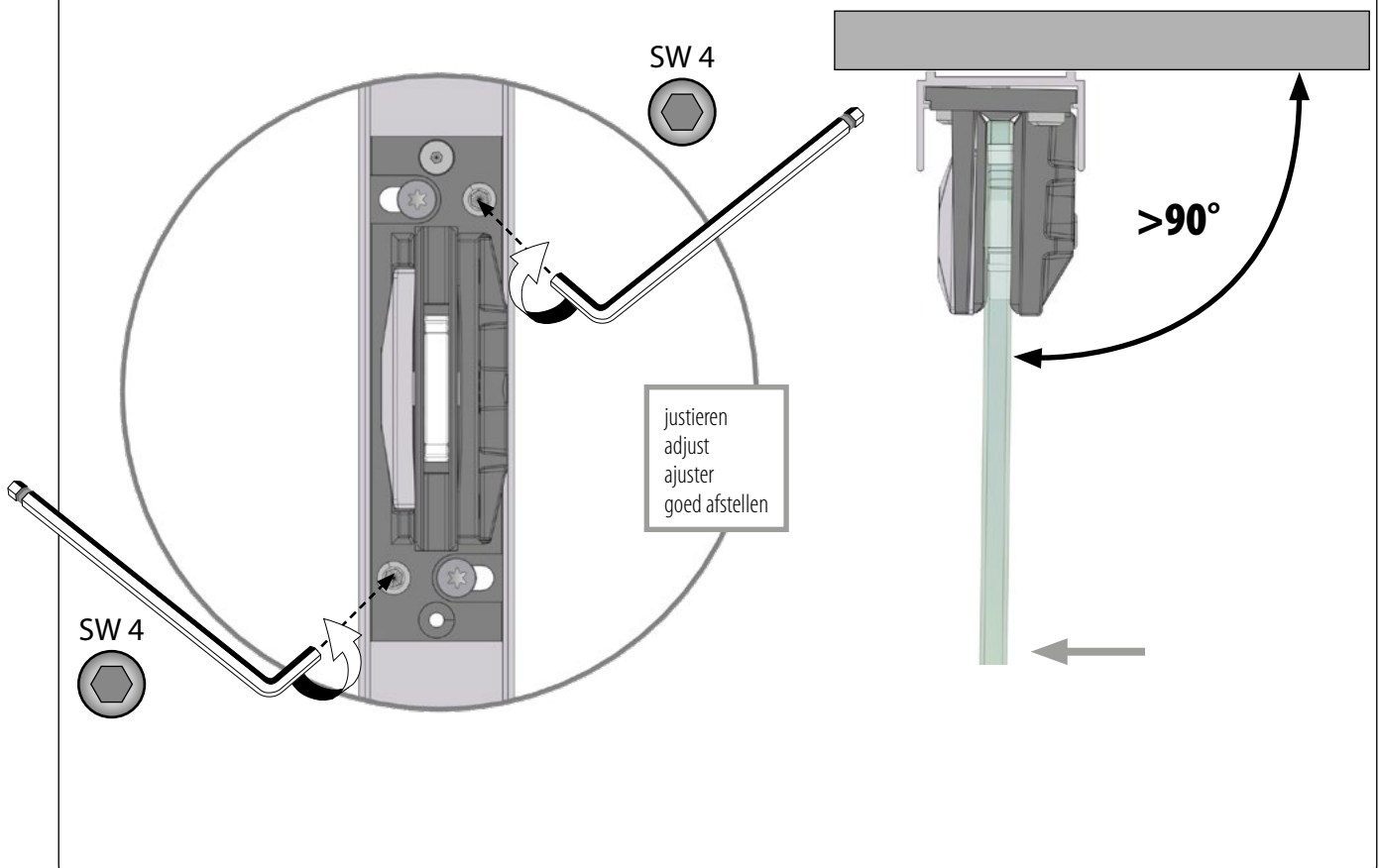
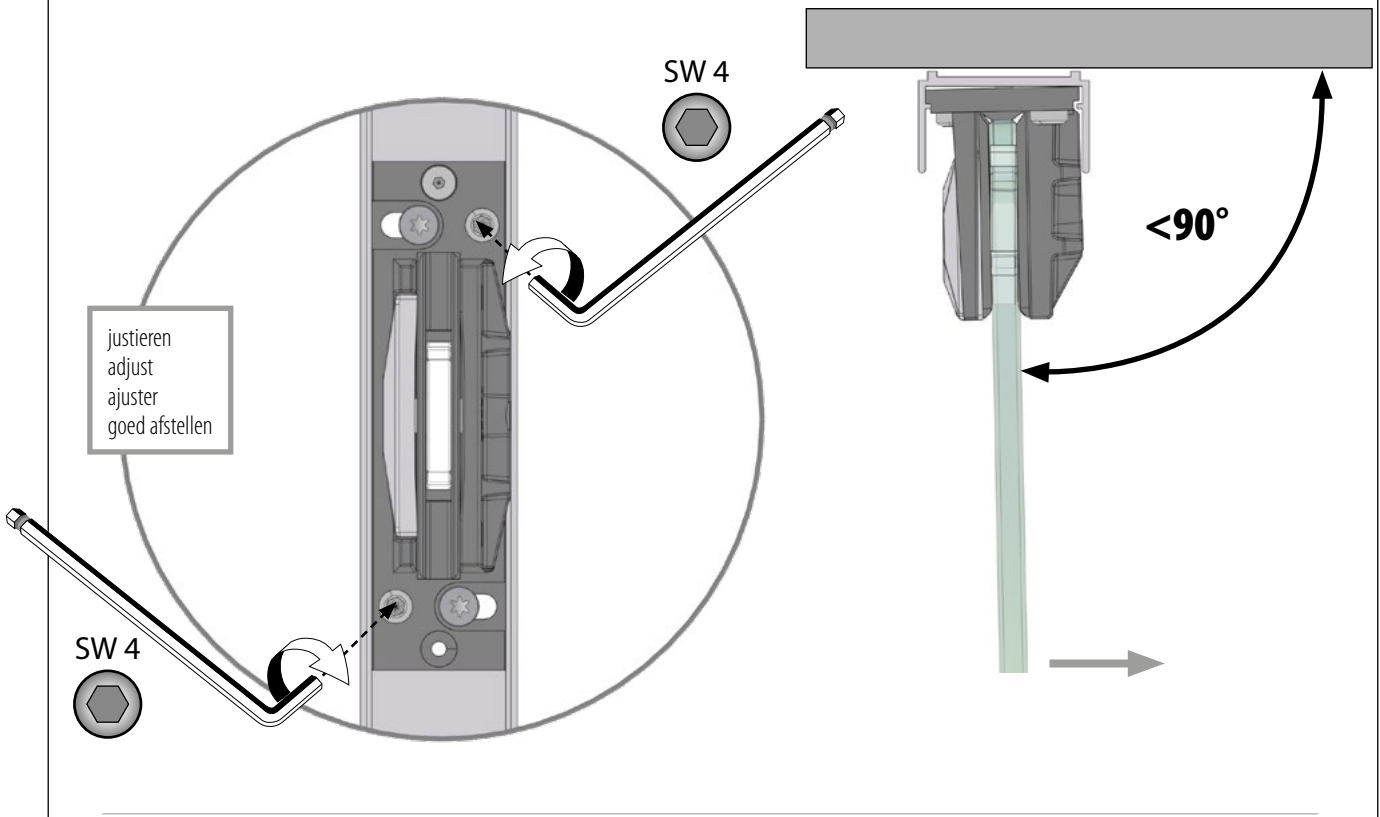

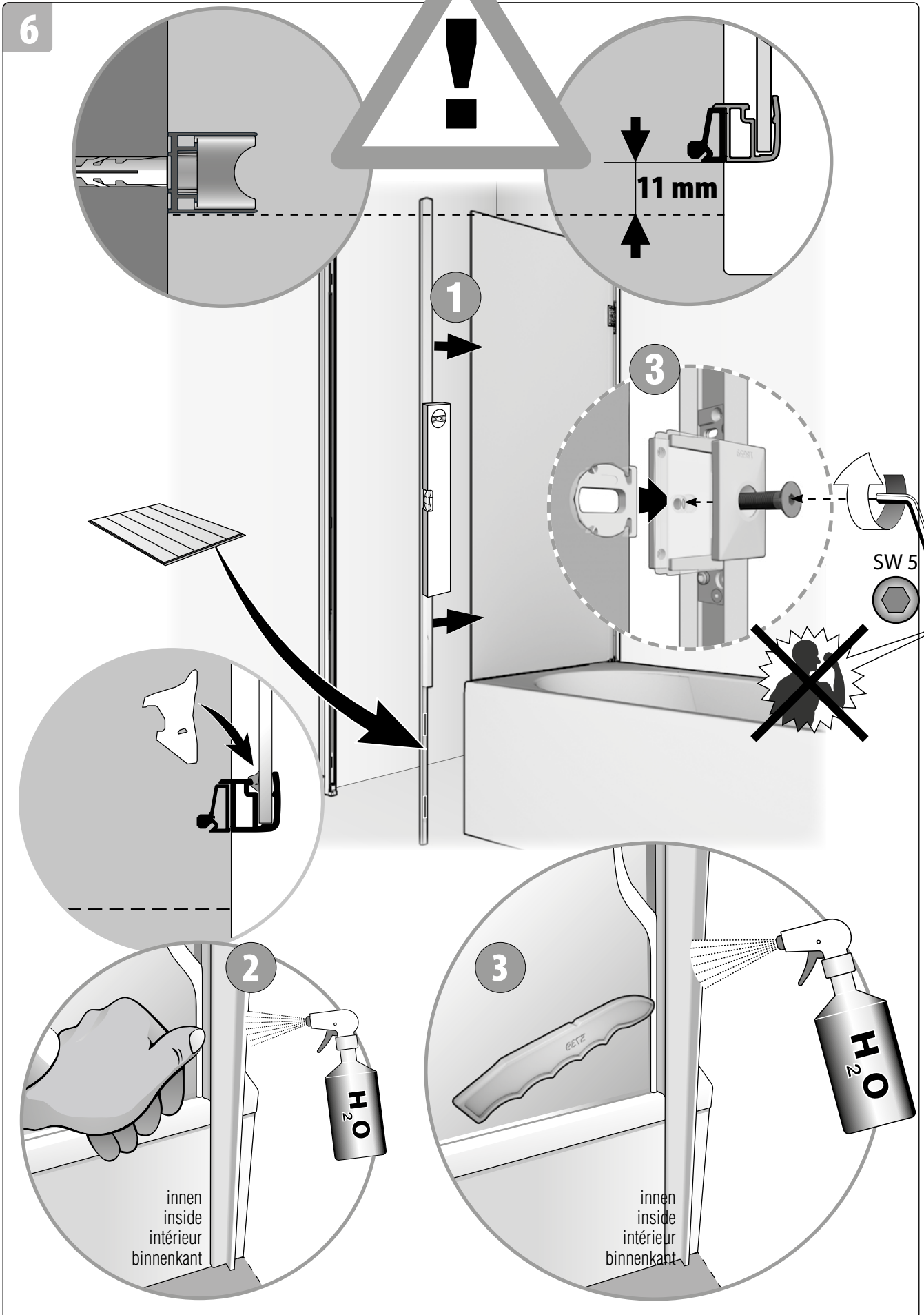

7

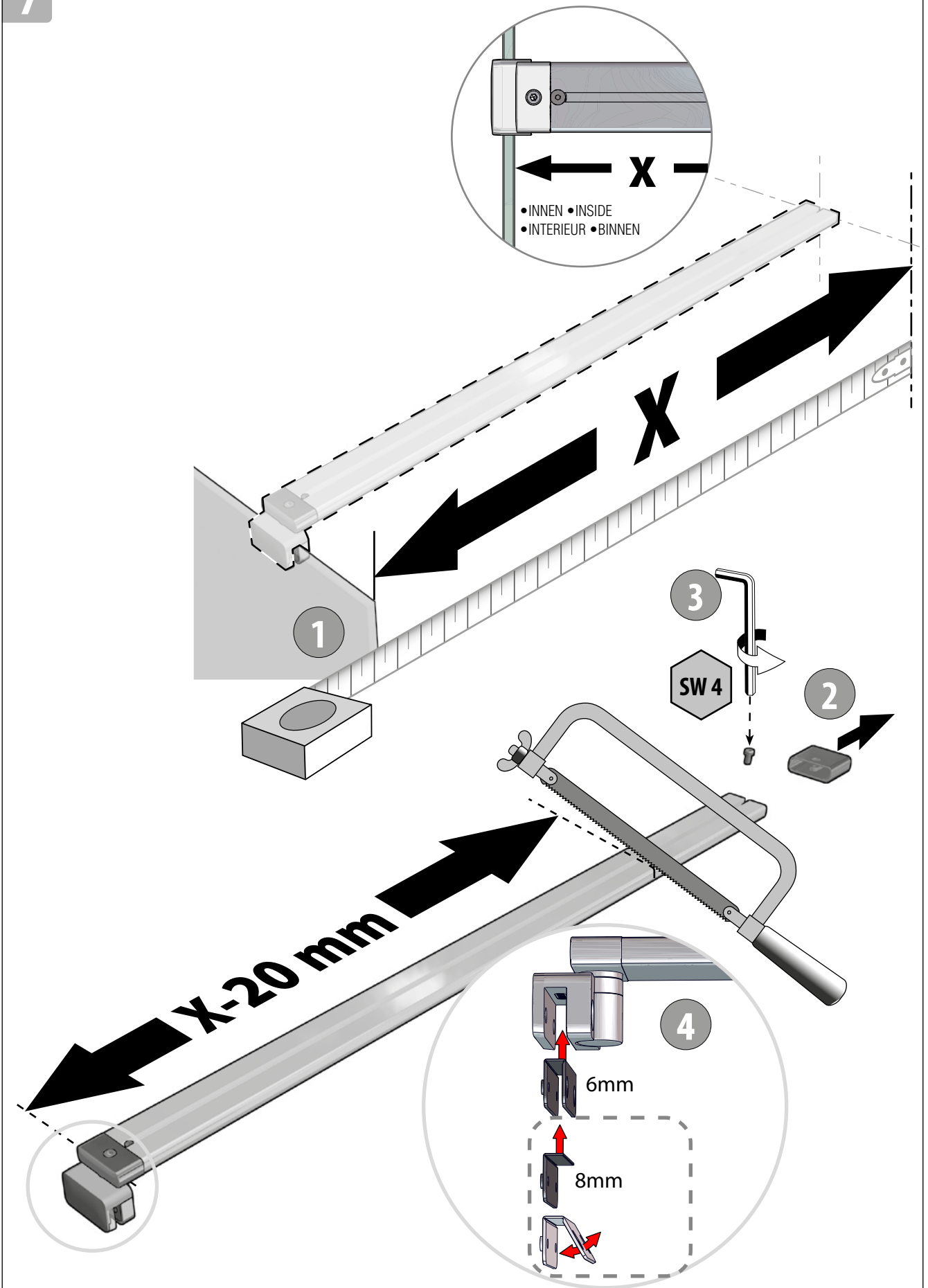

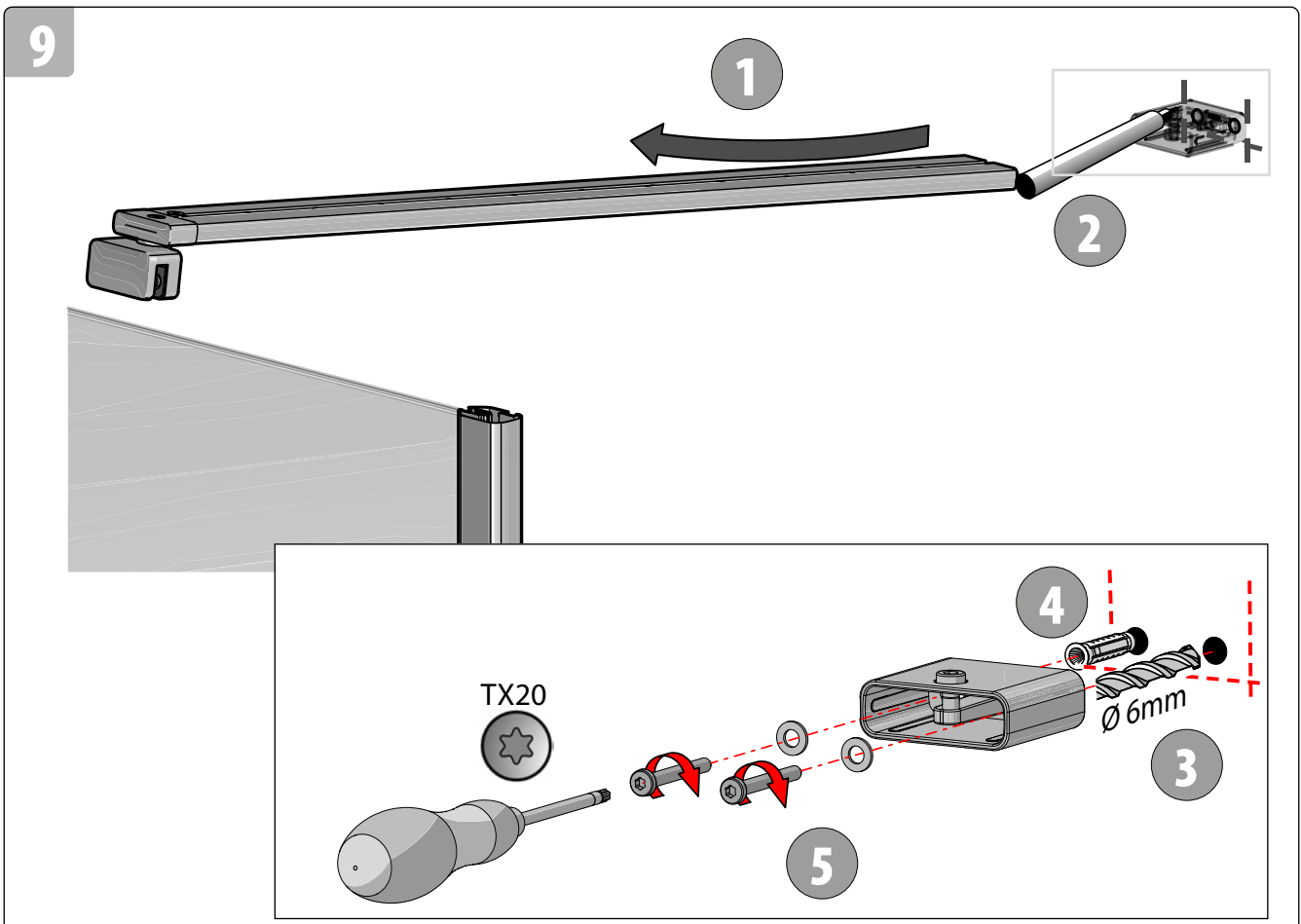
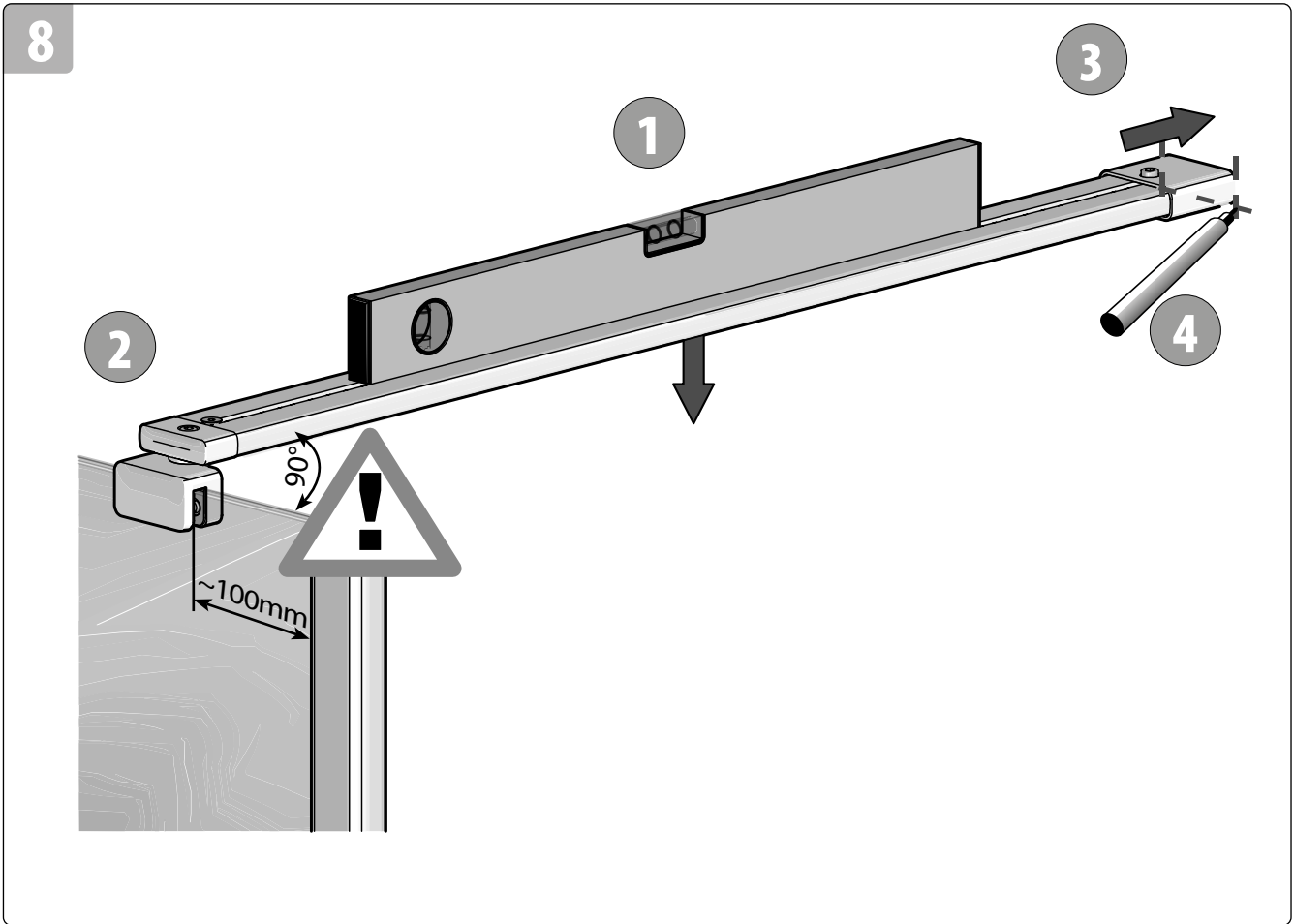

10

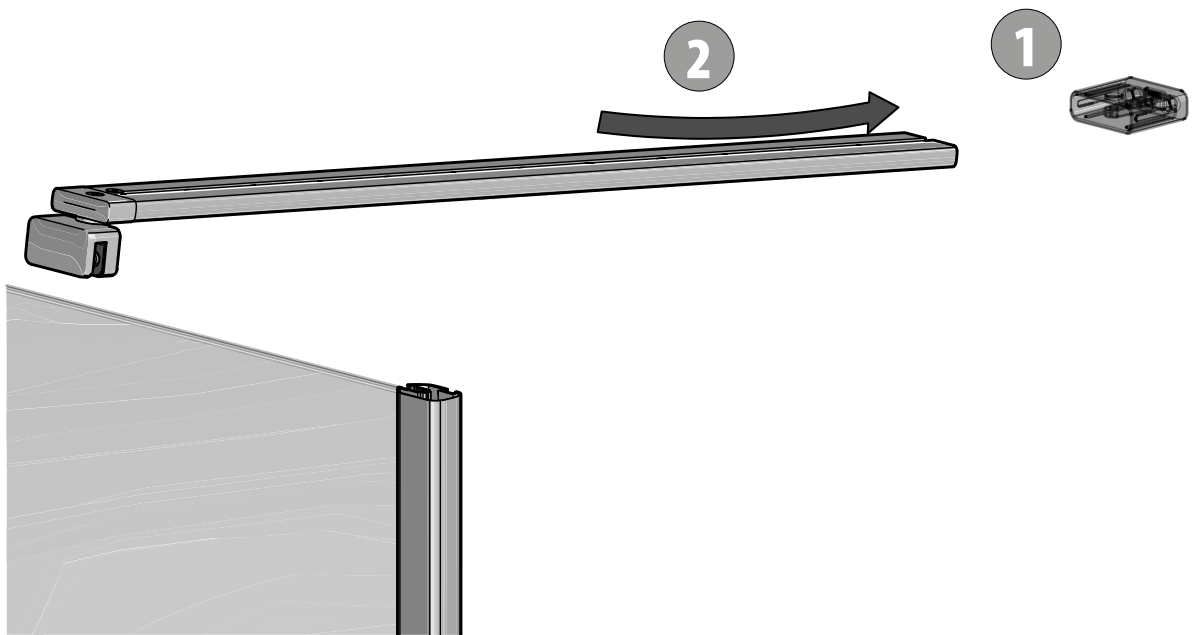

11

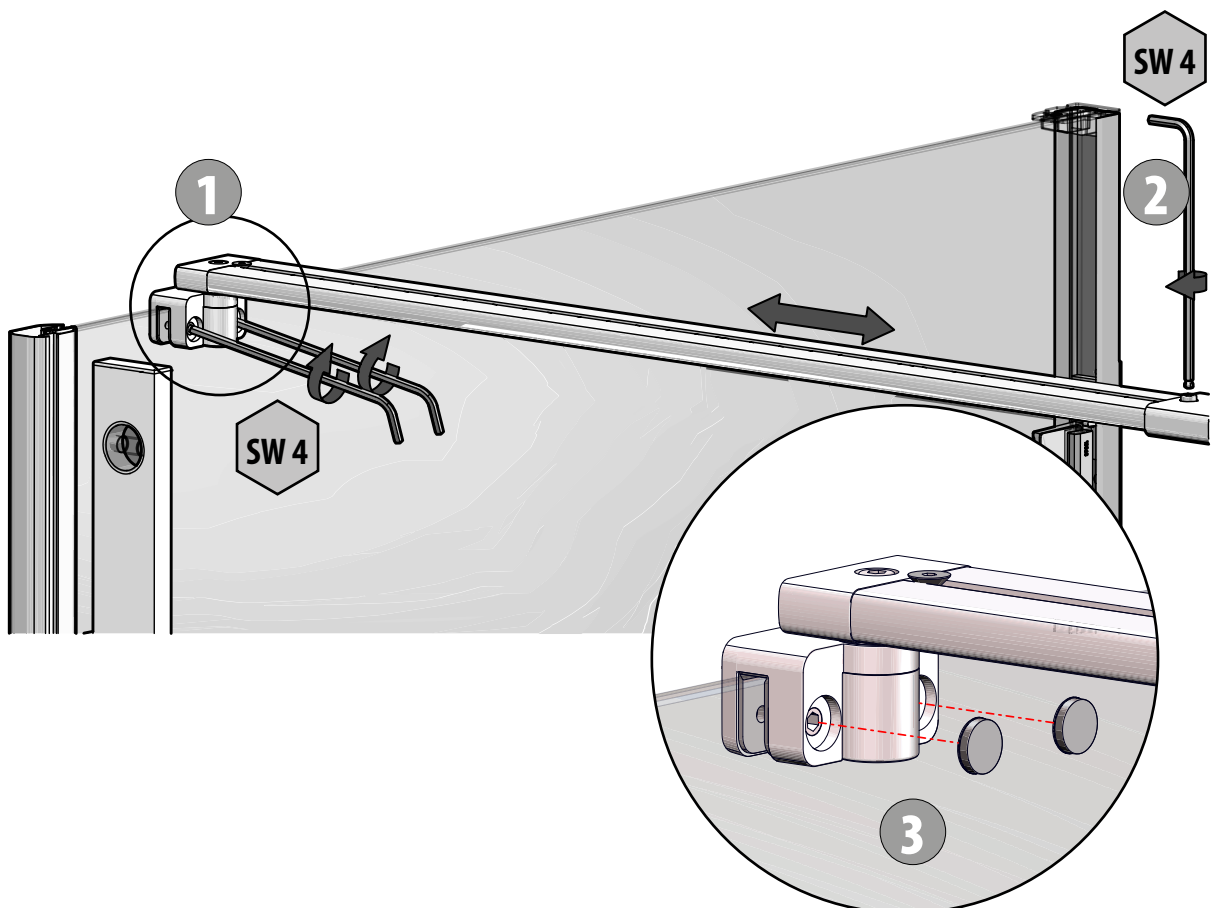

12

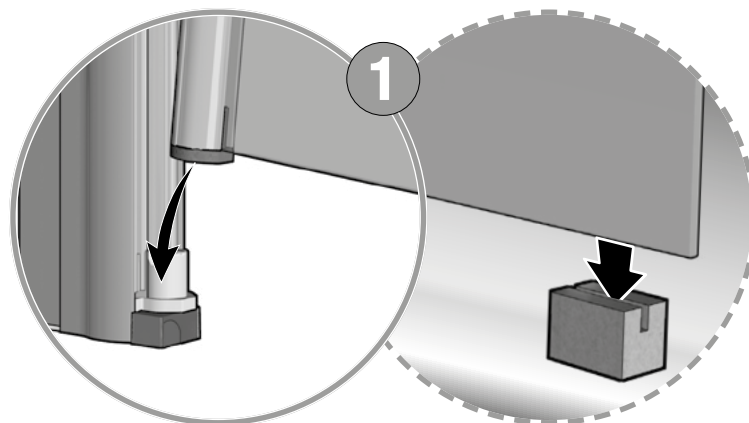
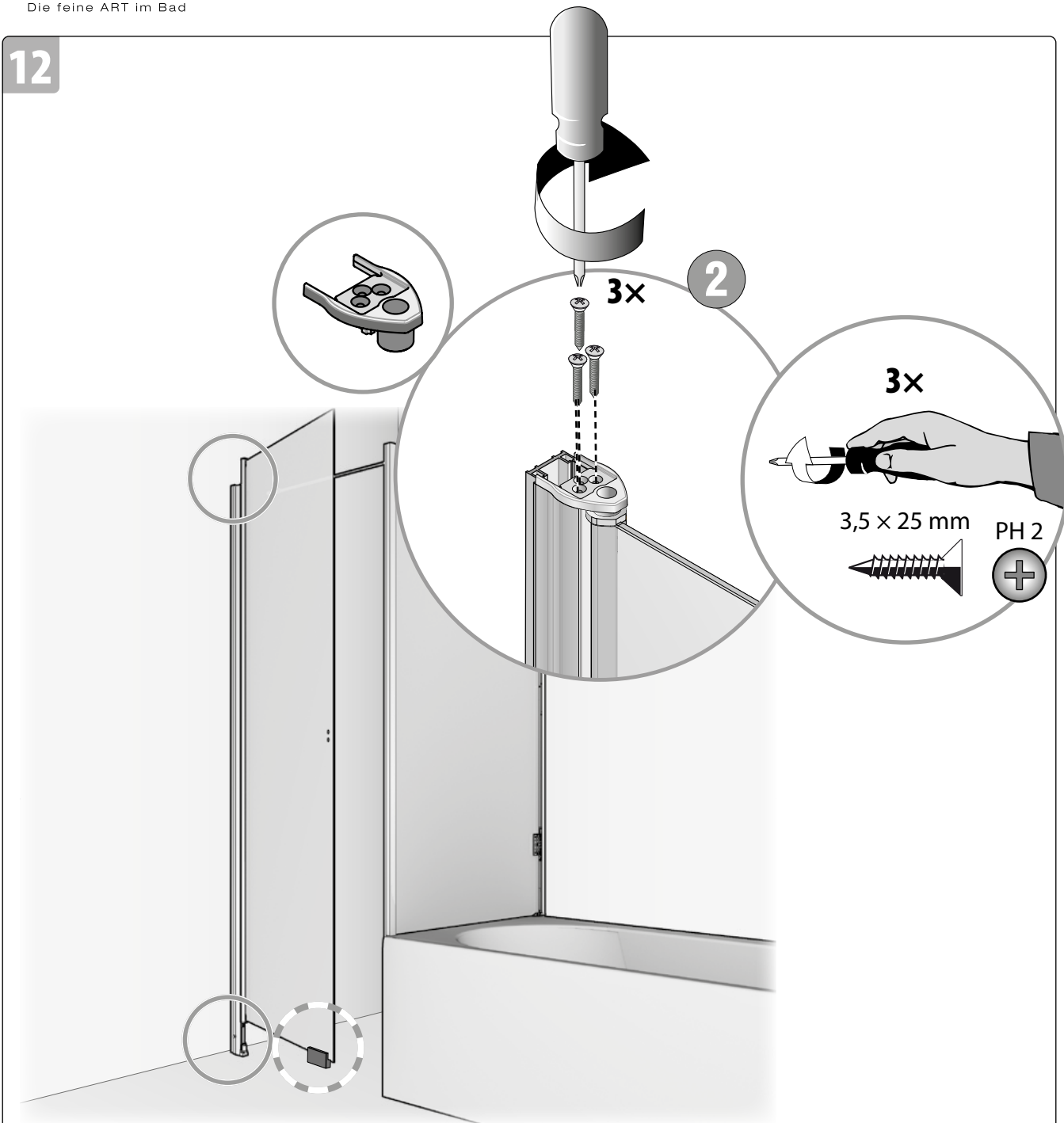

13

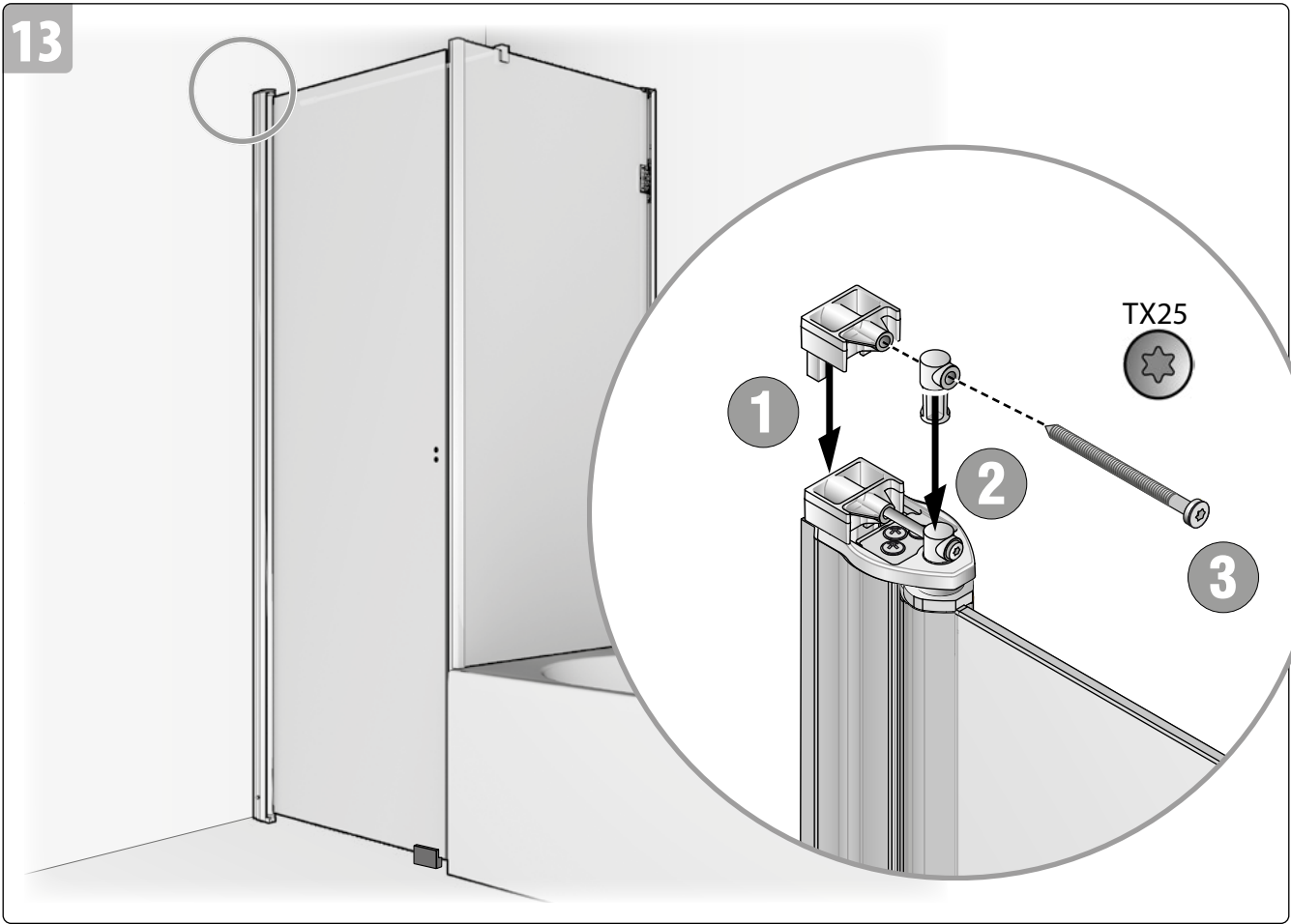

14

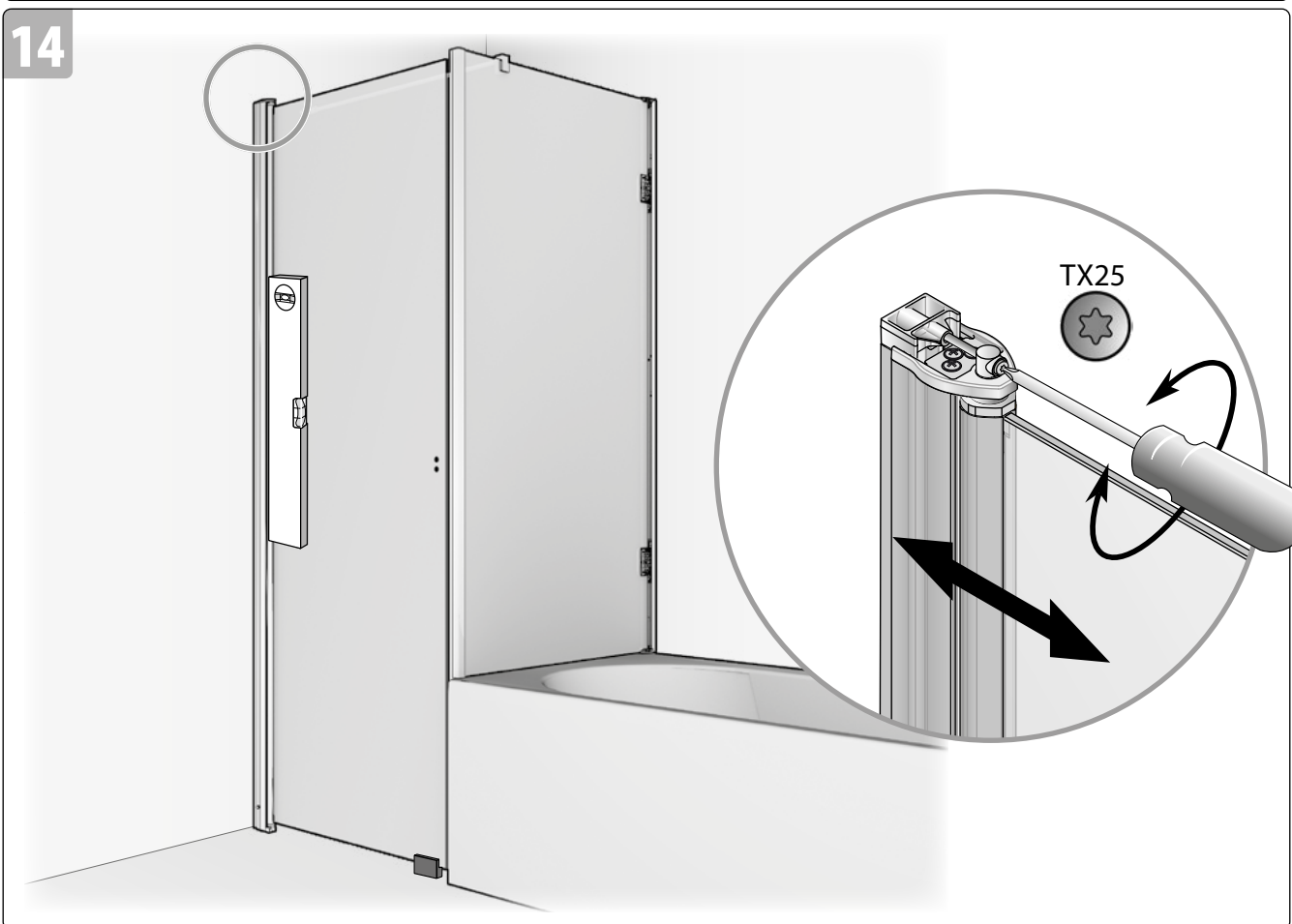

15

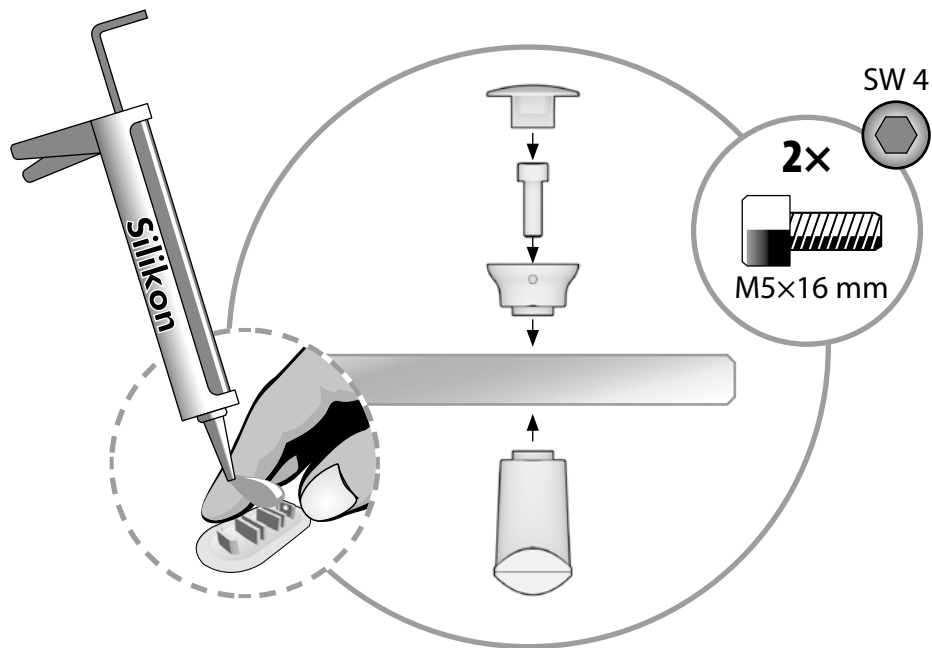
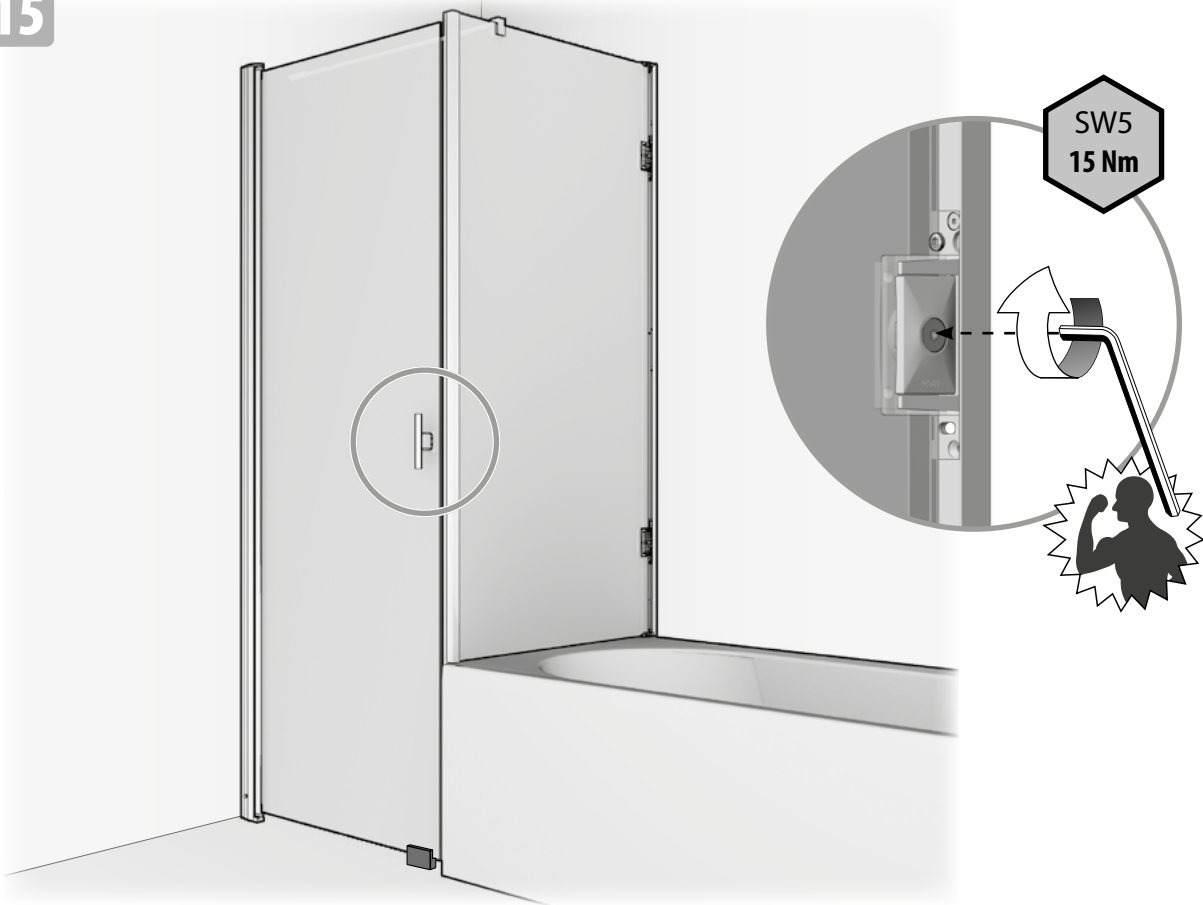

16

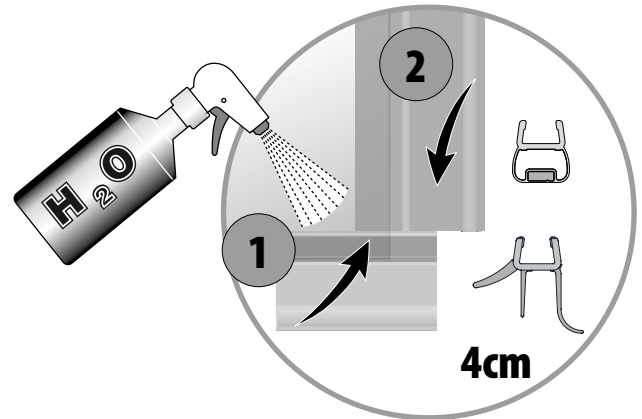
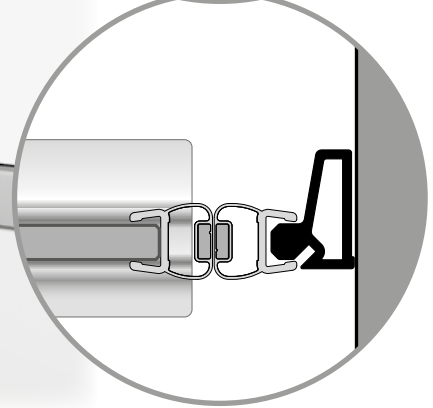
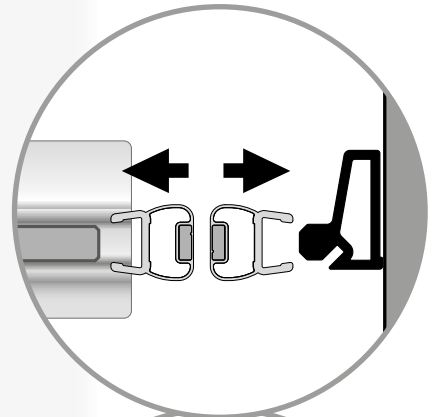

17

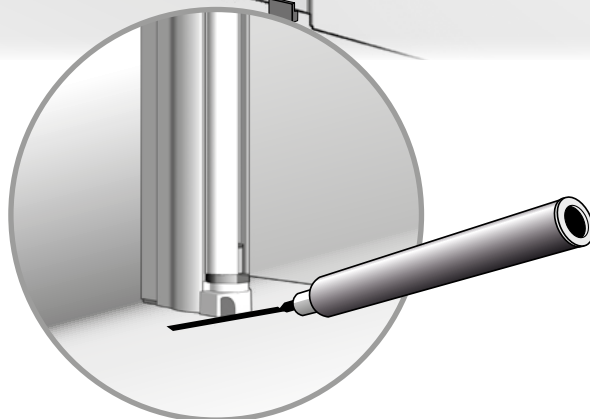
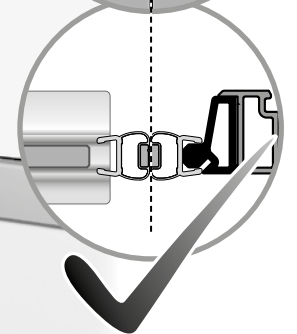
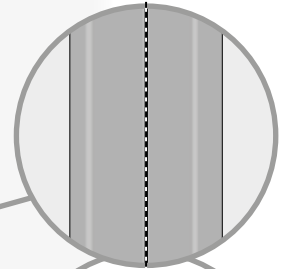
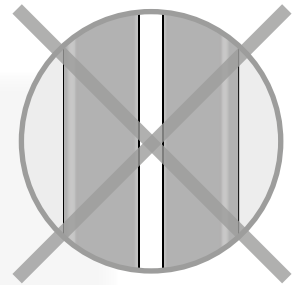
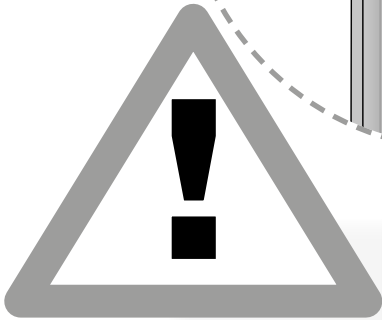
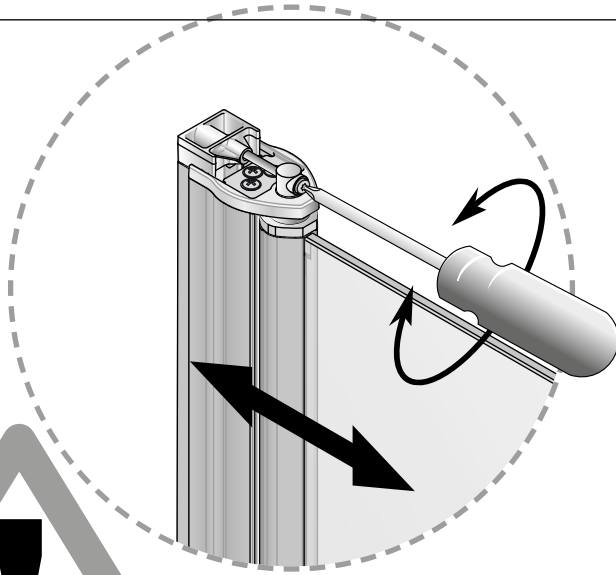

18

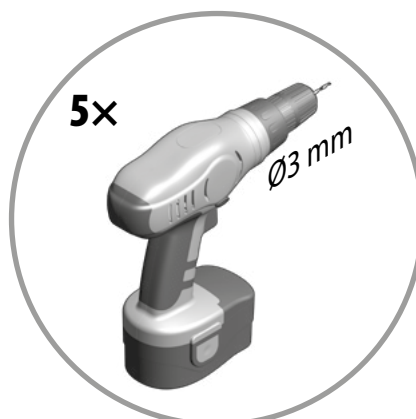
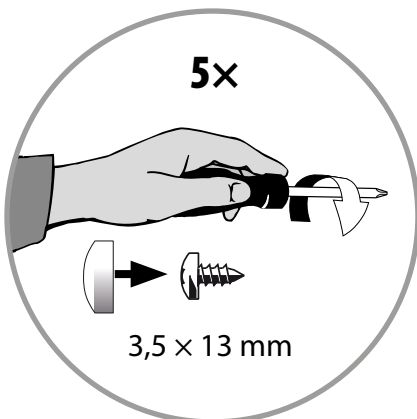
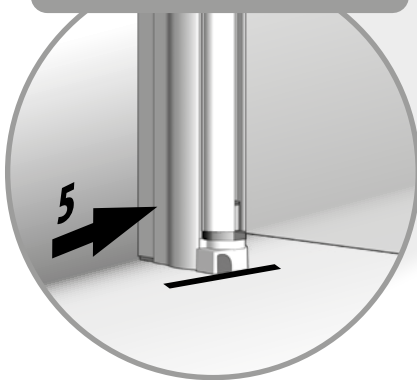
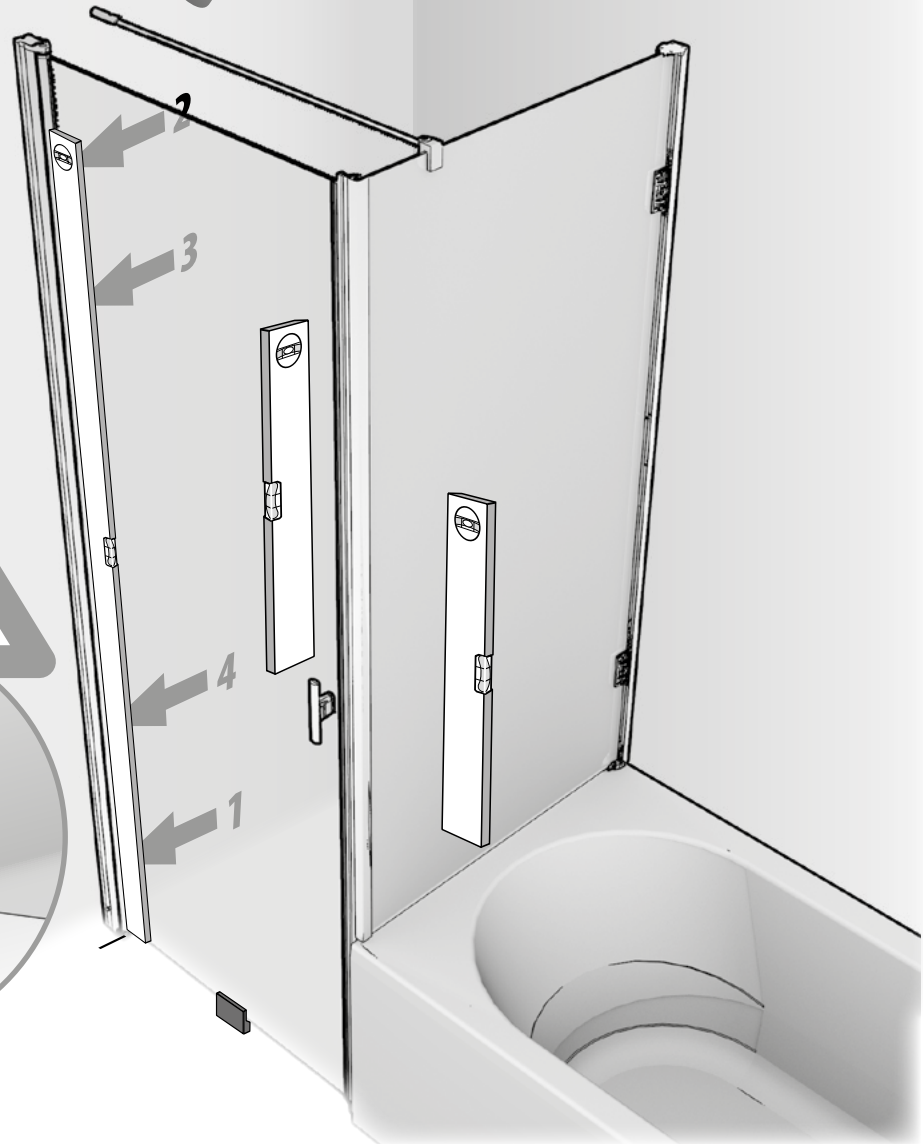
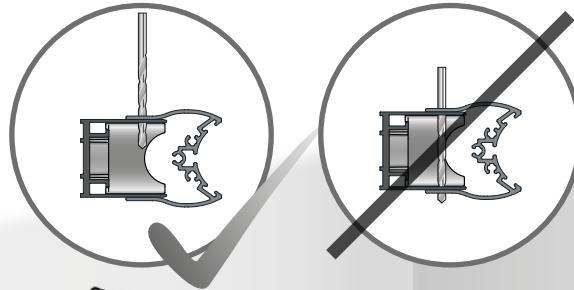

19

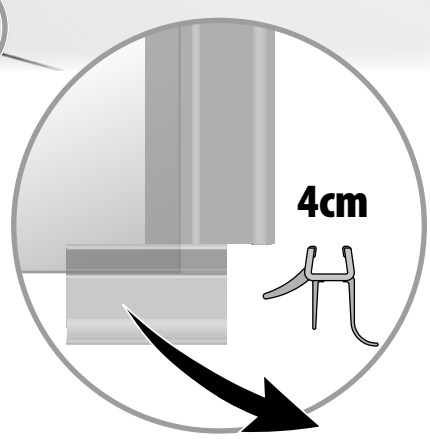
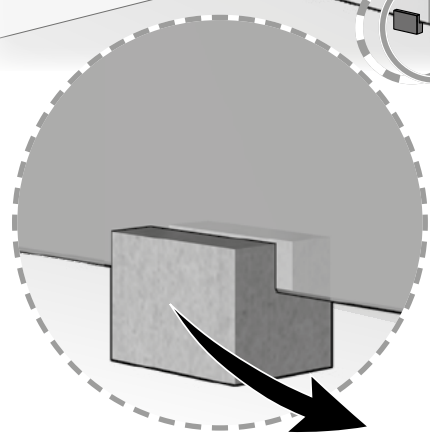
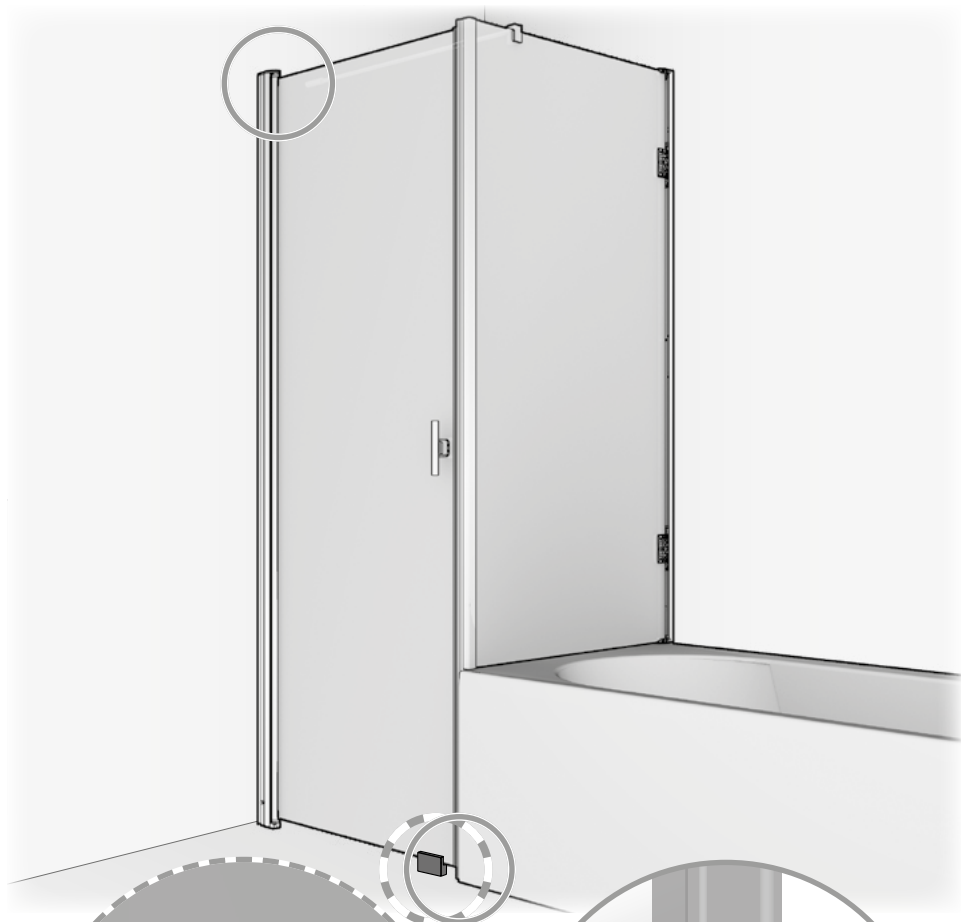
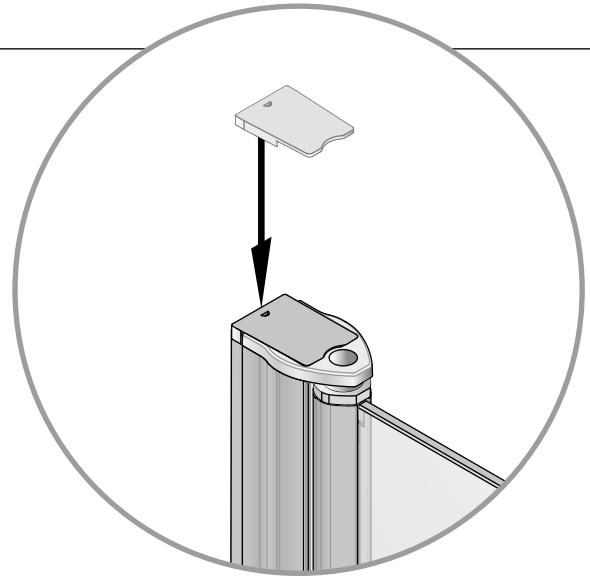
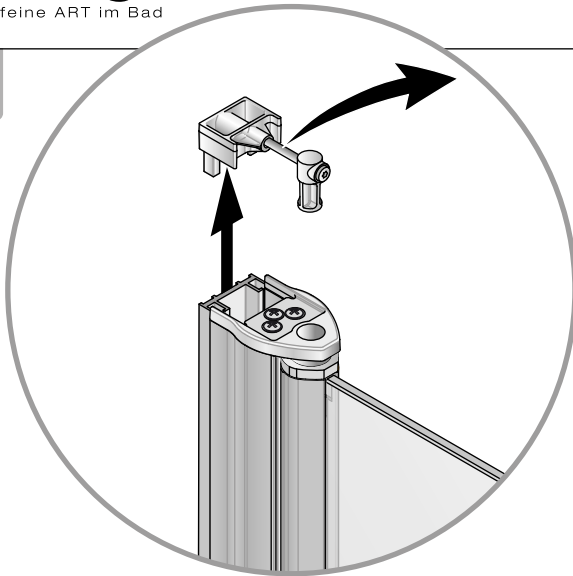

OPTIONAL	OPTIONAL	EN OPTION	OPTIONEEL
----------	----------	-----------	-----------

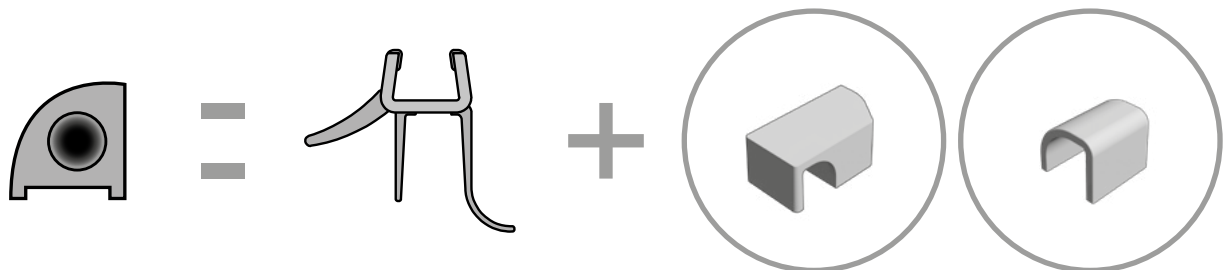
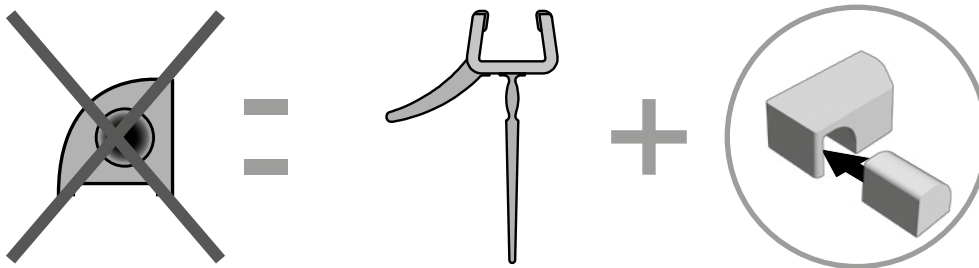

DE Der Hersteller weist an dieser Stelle ausdrücklich darauf hin, dass die Montage der im Lieferumfang enthaltenen Schwalleiste zur Erreichung der Dichtheitsanforderungen nach Norm (DIN 14428) erforderlich ist. Wird auf die Schwalleiste verzichtet, übernimmt der Hersteller keinerlei Haftung für daraus resultierende Schäden.

Eine spätere Montage der Führungsleiste ist ohne bauliche Veränderungen an der Duschtrennung möglich. Für diesen Fall bitte das nicht verwendete Montagematerial dem Endkunden zur Aufbewahrung übergeben.

EN At this stage the manufacturer makes a point of expressly informing you that mounting of the solid sealing strip delivered is necessary to achieve the degree of sealing required under the standard DIN 14428. If you dispense with the sealing strip, the manufacturer accepts no liability whatsoever for resulting damages.

It is possible to mount the surge strip at a later date without any changes to the shower side wall. In this case please hand over the unused fixation materials to the customer for storage.

FR A cet endroit, le fabricant indique expressément que le montage de la baguette de refoulement est indispensable pour obtenir l'étanchéité requise par la Norme (DIN 14428). Si toutefois cette baguette de refoulement n'est pas installée, le fabricant ne peut, en aucun cas, être tenu pour responsable des dégâts qui en résulteraient.

Le montage de la baguette de refoulement est toujours possible sans modification de la cabine de douche. Dans ce cas merci de remettre le matériel de montage non utilisé au client final pour le conserver.

NL De producent maakt u er op dit punt op attent, dat de montage van de in de levering opgenomen spatrand nodig is om aan de dichtheidseisen naar norm DIN 14428 te voldoen. Wanneer u afziet van montage van de spatrand, is de producent niet aansprakelijk voor eventuele daaruit vloeiende schade. Een latere montage van de spatrand is mogelijk zonder dat een bouwkundige verandering van de doucheafscheiding nodig is. In dit geval het niet het gebruikte montagemateriaal aan de eindklant geven om te bewaren.

20

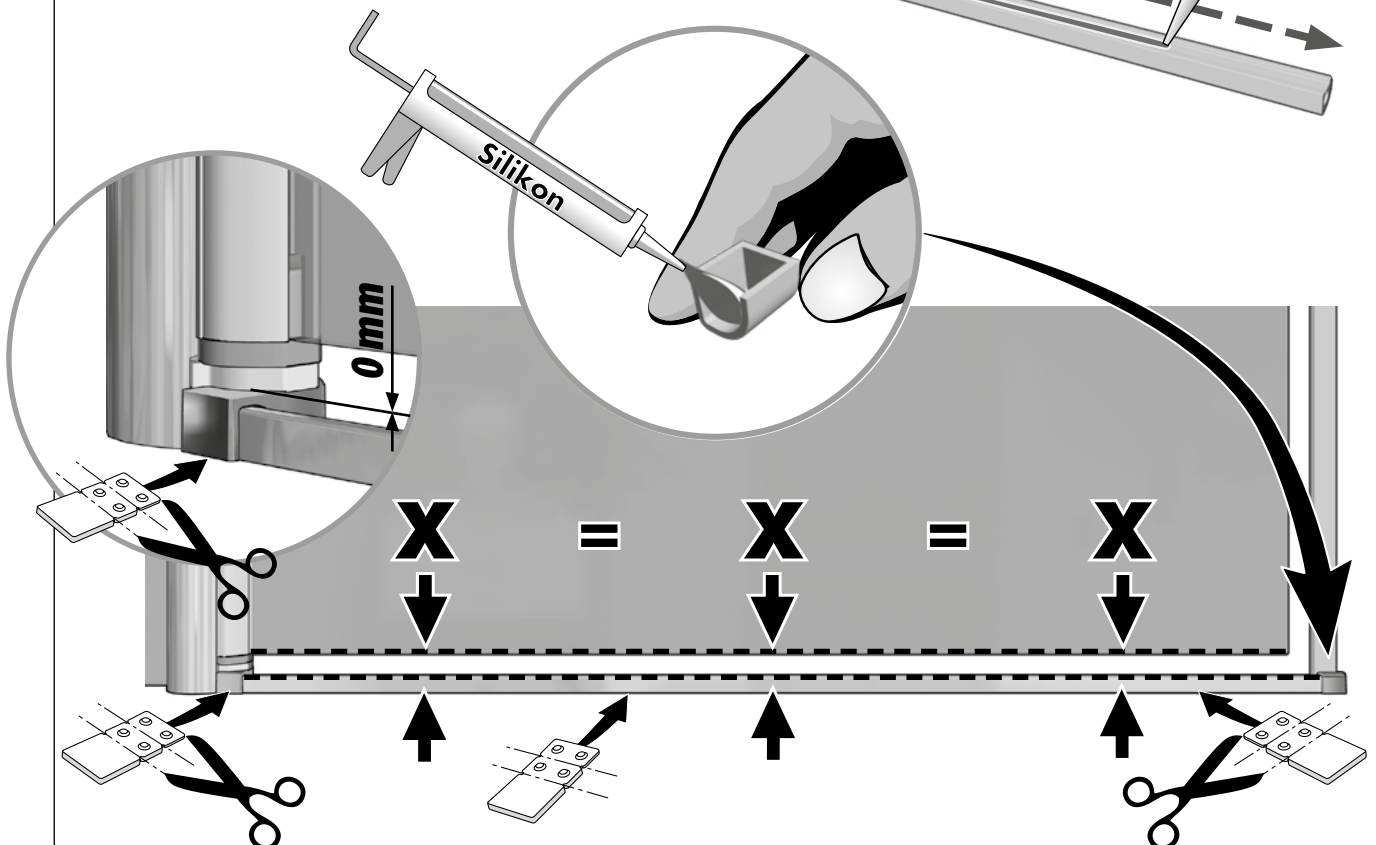
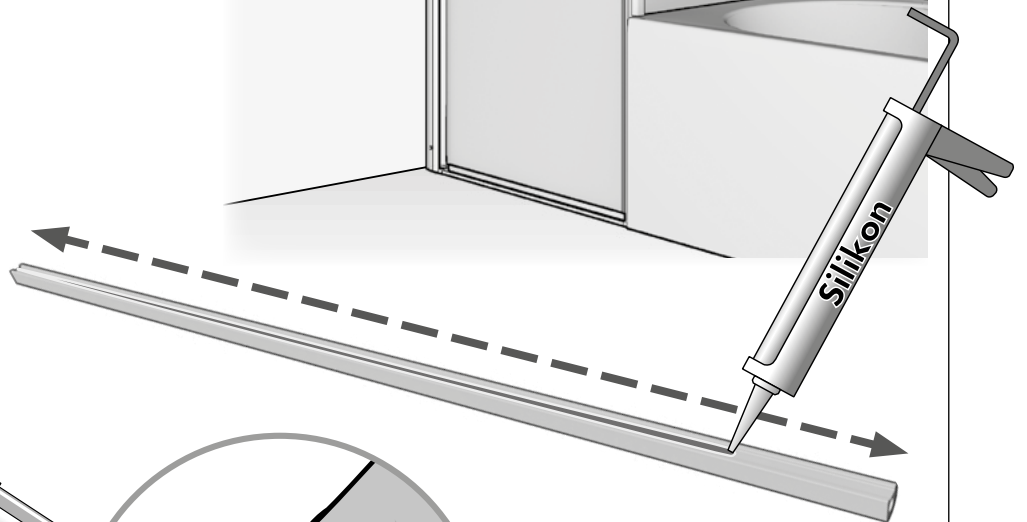
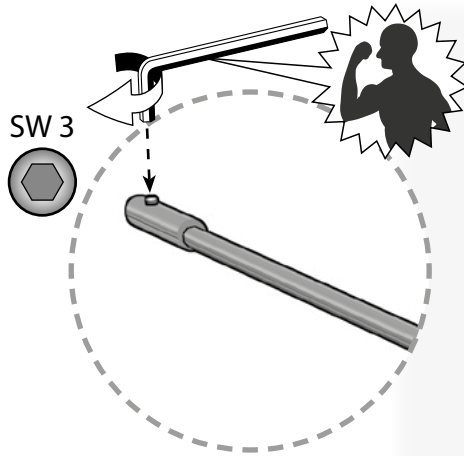

21

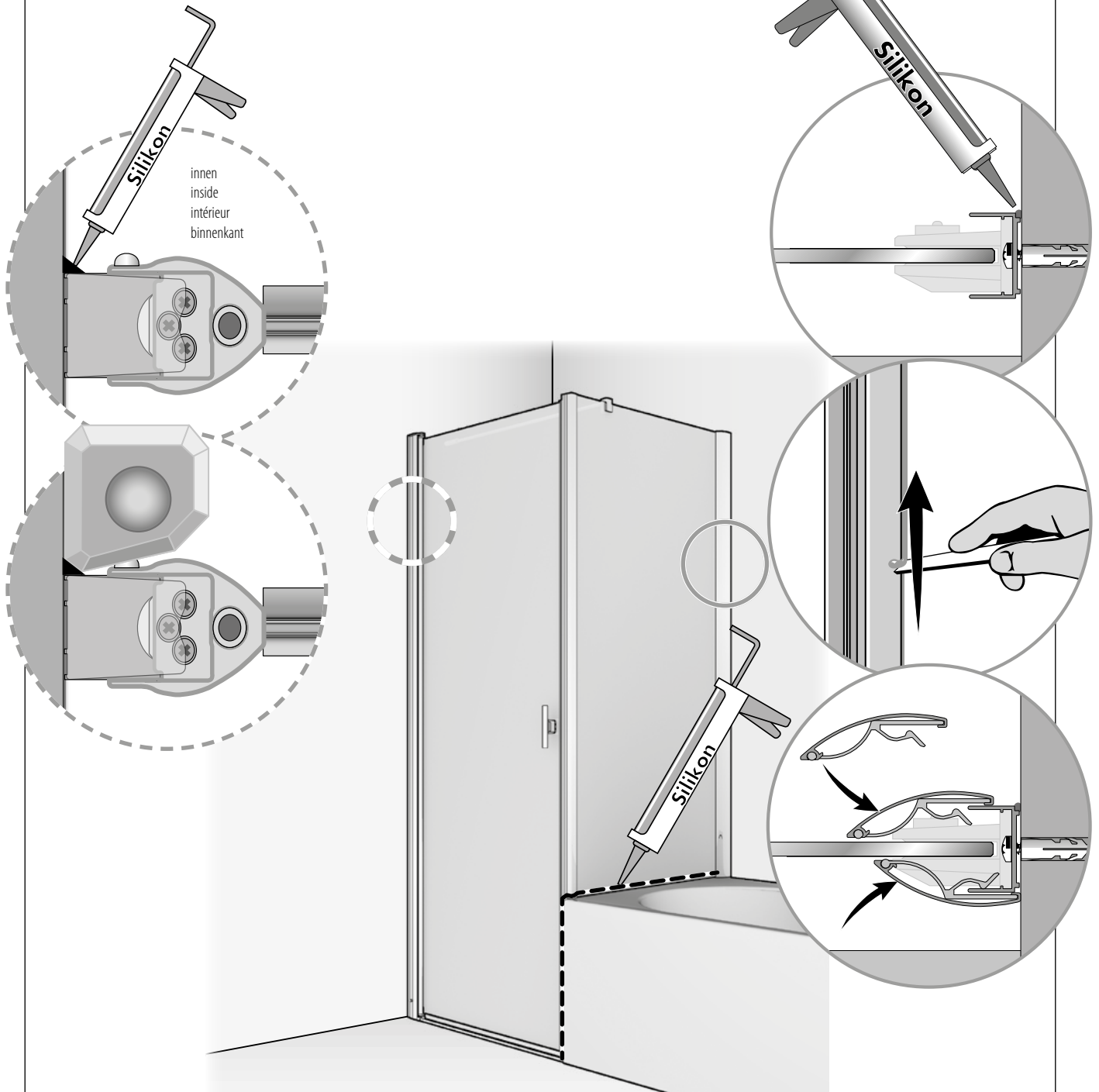

22

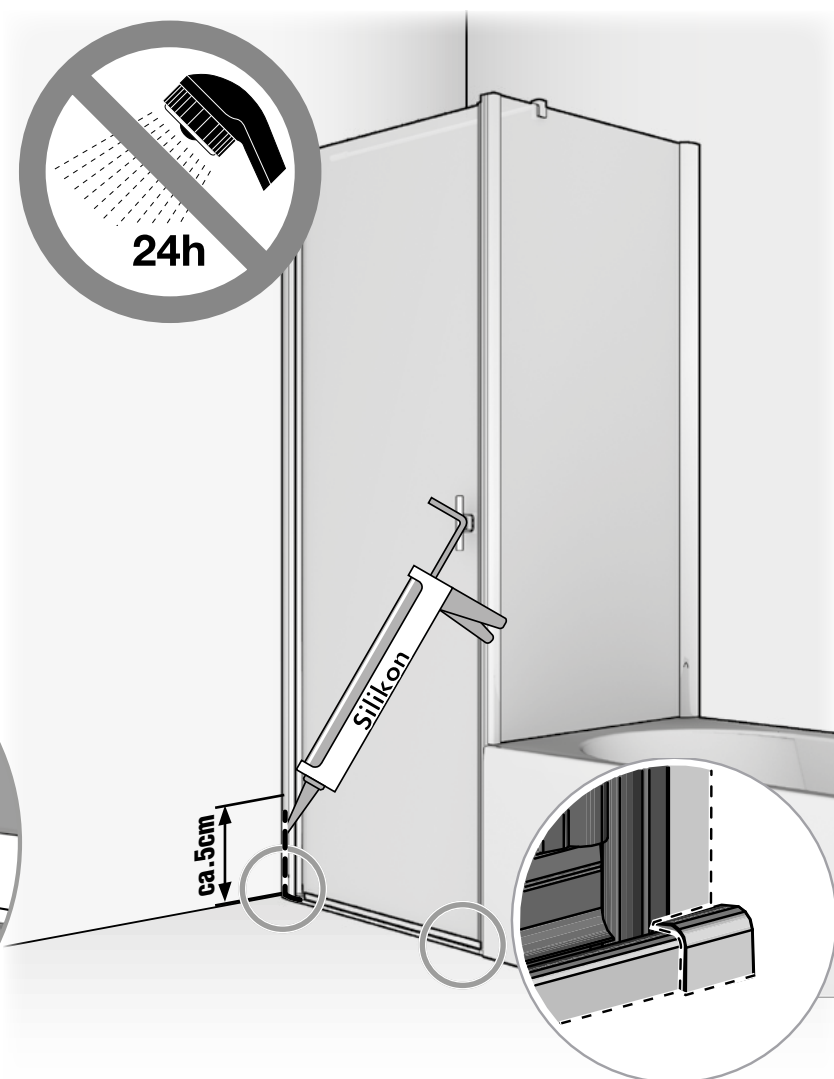
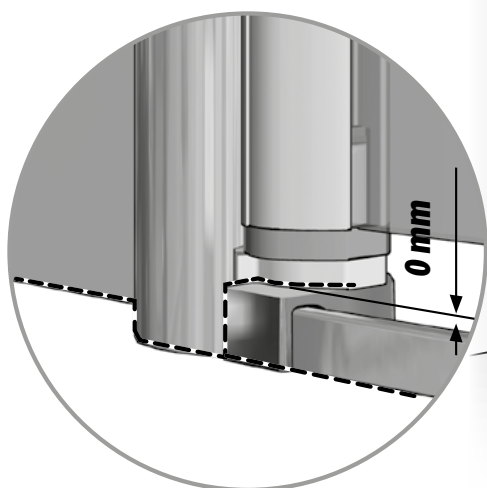
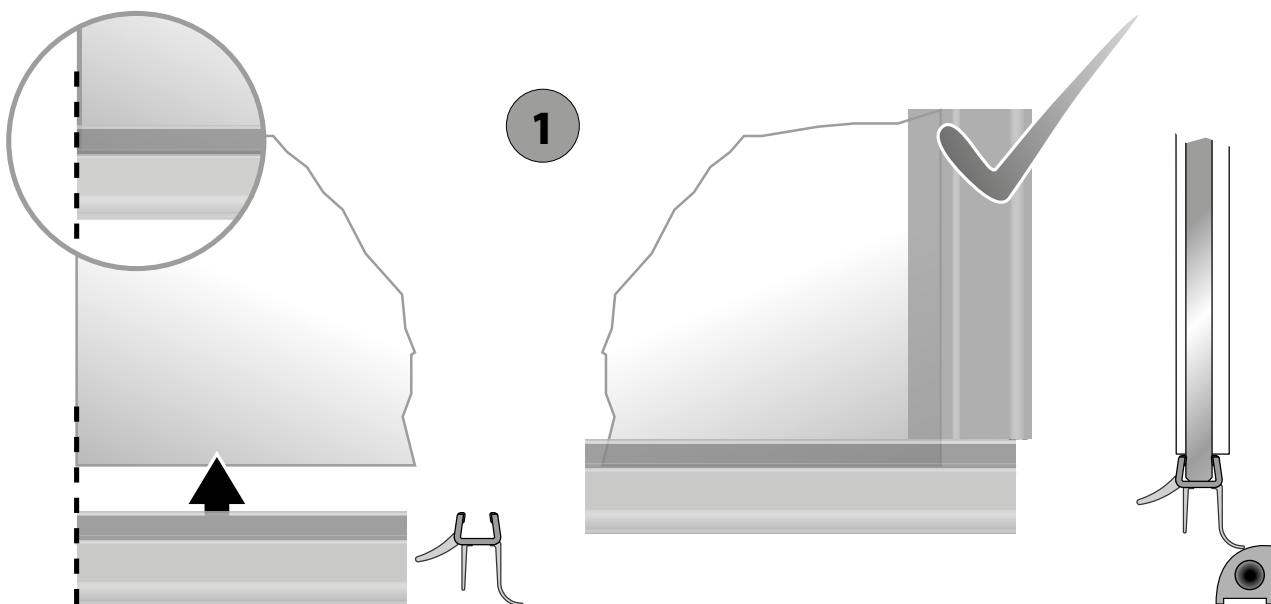

TWISTLINE

Pendeltür ohne Fixteil zu kurzer Seitenwand ab 10/2018

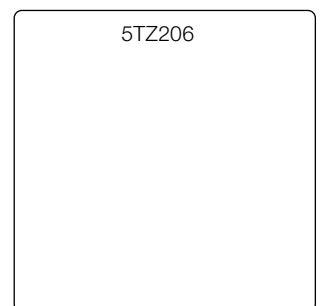
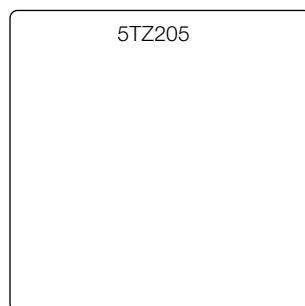
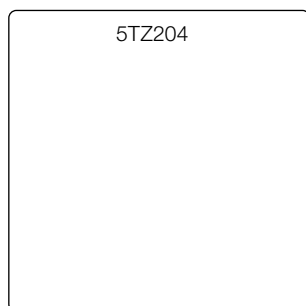
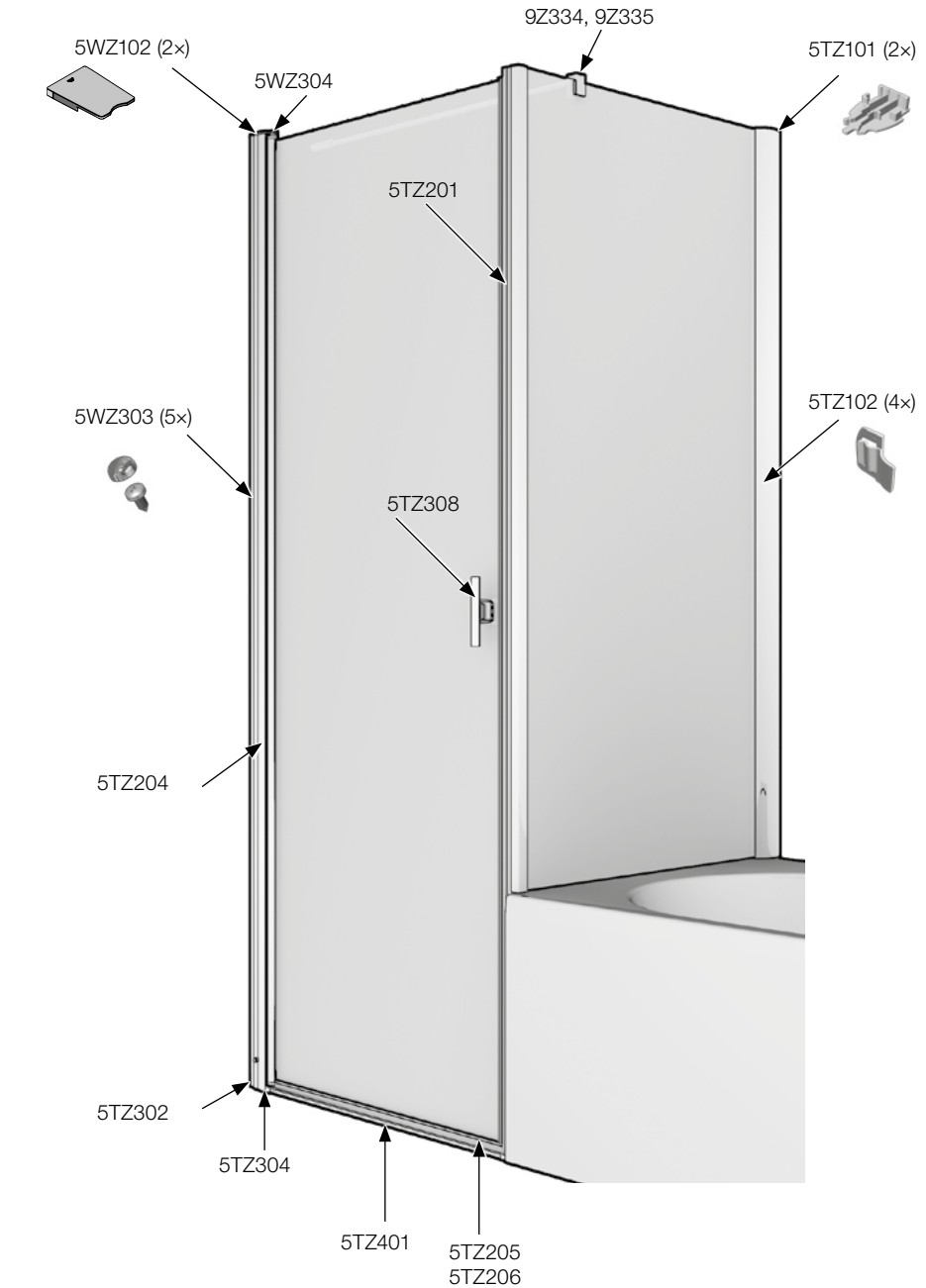
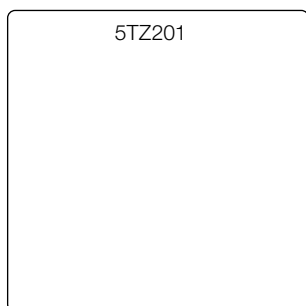
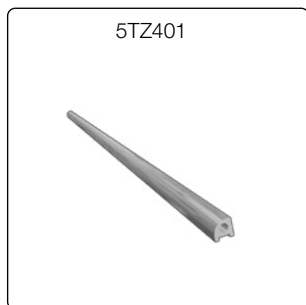
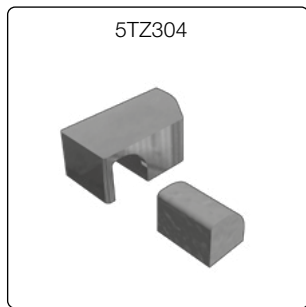
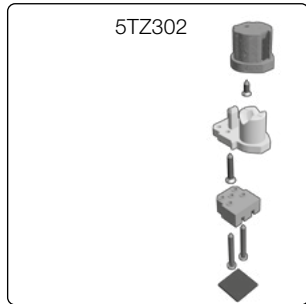
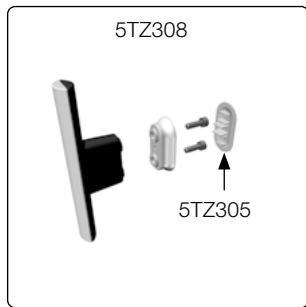

Artweger GmbH. & Co. KG
Sulzbacherstraße 60 | 4820 Bad Ischl | Austria
Tel. +43 6132 205-0 | Fax +43 6132 205-5001
info@artweger.at | www.artweger.at

Verkauf Deutschland
Artweger GmbH. & Co. KG
Postfach 1169 | 83402 Ainring | Deutschland
Tel. 0800 1114442-0 | Fax 0800 1114442-5002
info@artweger.de | www.artweger.de

Verkauf Schweiz
Artweger GmbH. & Co. KG
Postfach 16 | CH-4202 Duggingen
Tel. + 41 61 751 90 91 | Fax + 41 61 751 63 54
info@artweger.com | www.artweger.com



Druck- und Satzfehler sowie technische Änderungen vorbehalten.
Typographical errors and technical changes reserved.
Sous réserve d'erreurs d'impression ou de syntaxe ainsi que de modifications techniques.
Drukfouten, maatwijzingen en technische veranderingen voorbehouden.
Ci riserviamo errori di stampa e variazioni tecniche.