

MONTAGEANLEITUNG

2-tlg. Falttür zu Seitenwand ohne Fixteile

5 F 2 1 . H

5 F 2 2 . H

5 F 2 . 8 8

ASSEMBLY INSTRUCTIONS

Double folding door next to side screen without fixed parts

NOTICE DE MONTAGE

Porte pliante à 2 panneaux pour montage avec paroi fixe sans parties fixes

MONTAGEVOORSCHRIFT

2-delige vouwdeur voor de zijwand zonder vaste delen



Vor Gebrauch sorgfältig lesen! Zum Nachschlagen und Aufbewahren dem Endkunden übergeben!

Read carefully before use! Hand over to the customer for looking up and storage!

Avant emploi lire soigneusement! Remettez le au client pour la recherche et le stockage!

Voordien gebruik zorgvuldig lezend! Overhandig de klant voor het kijken omhooggaand en opslag!

DEUTSCH
Originalsprache

ENGLISH
Translation

FRANCAIS
Traduction

NEDERLANDS
Vertaling

INHALTSVERZEICHNIS	OVERVIEW
INHALTSVERZEICHNIS2	OVERVIEW2
SICHERHEITS- HINWEISE4	SAFETY- INSTRUCTIONS4
BENÖTIGTES WERKZEUG6	NECESSARY TOOLS6
MONTAGESET7	ASSEMBLY KIT7
MONTAGE VARIANTEN8	ASSEMBLY VARIATIONS8
VERSTELLBEREICH8	ADJUSTMENT RANGE8
MONTAGE VARIANTEN9	ASSEMBLY VARIATIONS9
WANNEN EINBAUMASS9	TRAY INSTALLATION MEASUREMENT9
MONTAGE10	ASSEMBLY10
» WANDANSCHLUSS10	» INSTALLATION OF IMMOVABLE ELEMENT10
» MONTAGE STABILISATOR14	» INSTALLATION OF STABILIZER14
» TÜRTEIL16	» DOOR PART16
» TÜRTEIL 219	» DOOR PART 219
» GRIFF19	» HANDLE19
» MONTAGE DICHTLEISTEN19	» INSTALLATION OF SEALING STRIP19
» MONTAGE DICHTLEISTEN23	» INSTALLATION OF SEALING STRIP23
» ABDICHTEN MIT SANITÄRSILIKON24	» SEALING WITH SANITARY SILICONE24
ERSATZTEILE25	SPARE PARTS25
 Montageanleitung für Einbau LINKS - bei Einbau RECHTS–spiegelgleicher Aufbau.	 Assembly instructions for installation LEFT - for installation RIGHT–assemble in mirror image.

VUE D'ENSEMBLE	OVERZICHT
VUE D'ENSEMBLE3	OVERZICHT3
INSTRUCTIONS- SÉCURIT.....4	VEILIGHEIDS- VOORSCHRIFTEN4
OUTILLAGE NECESSAIRE6	BENODIGD GEREEDSCHAP6
SET DE MONTAGE.....7	MONTAGESET7
VARIANTES DE MONTAGE.....8	MONTAGE VARIANTEN.....8
POSITIONNEMENT8	VERSTELBAARHEID.....8
VARIANTES DE MONTAGE.....9	MONTAGE VARIANTEN.....9
MESURES POUR MON TAGE SUR RECEVEUR.....9	DOUCHEBAK INBOUWMAAT9
MONTAGE10	MONTAGE10
» MONTAGE PARTIE FIXE10	» MONTAGE VAST DEEL10
» MONTAGE STABILISATEUR14	» MONTAGE STABILISATOR14
» ELÉMENT DE PORTE16	» DEURDEEL.....16
» ELÉMENT DE PORTE 2.....19	» DEURDEEL 219
» POIGNÉE19	» GREEP19
» MONTAGE BAGUETTES D'ÉTANCHÉITÉ19	» MONTAGE AFDICHTINGEN19
» MONTAGE BAGUETTES D'ÉTANCHÉITÉ23	» MONTAGE AFDICHTINGEN23
» ETANCHER AVEC DU SILICONE SANITAIRE.....24	» AFDICHTEN MET SANITAIR-SILICONEN.....24
PIÈCES DÉTACHÉES25	ONDERDELEN25

C'est prévue pour une installation à GAUCHE –
en cas d'une installation à DROITE -A inverser pour partie fixe en GAUCHE.

Montagevoorschrift voor inbouw LINKS -
bij inbouw RECHTS—montage in spiegelbeeld.

SICHERHEITS- HINWEISE

SAFETY- INSTRUCTIONS

INSTRUCTIONS- SÉCURITÉ

VEILIGHEIDS- VOORSCHRIFTEN

DE Vor dem Einbau bitte unbedingt beachten!

- Produkt **vor dem Einbau**, auf Richtigkeit, Beschädigungen und das Zubehör auf Vollständigkeit **überprüfen**.
- **Bei sichtbarem Schaden Produkt keinesfalls einbauen!**
- **Beachten Sie beim Hantieren das teilweise hohe Gewicht und/oder die großen Abmessungen von Einzelteilen.**
- **Beachten Sie beim Bohren der Löcher, dass Sie keine Leitungen (Elektro, Gas, Wasser) beschädigen.**



Unsere Haftung beschränkt sich alleine auf unsere Produkte und kann daher nicht auf den Ein- und Ausbau ausgedehnt werden. Die Kosten für einen nachträglichen Aus- und Einbau eines Produkts und die damit verursachten Schäden sind **kein** Bestandteil der Garantie.

EN Please note carefully before installing

- Before installing, check for correctness and damage and the accessories for completeness.
- **Do not under any circumstances install product with visible damage!**
- **Take the great weight and/or the large dimensions into consideration when handling individual parts!**
- **When drilling holes do not damage hidden pipes and wiring.**

Our liability is limited to our products alone and therefore cannot be extended to installation and dismantling. Costs for subsequent dismantling and installation of a product and damage caused thereby are not part of the guarantee.

FR A respecter impérativement avant le Montage

- Avant le montage de vérifier qu'il s'agit du bon modèle, qu'elle n'est pas endommagée et que les accessoires sont complets.
- **En cas de dommages visibles, ne pas monter le produit!**
- **Lors de la manutention, merci de prêter attention au poids parfois très élevé et/ou aux dimensions de certaines pièces!**
- **Faites attention en perçant les trous de ne pas endommager les tuyauteries (cables électriques, canalisations de gaz, d'eau, etc).**

Notre responsabilité se limite à nos produits et ne peut être étendue sur l'installation et le démontage. Les coûts générés lors d'un démontage après installation et d'une ré-installation d'un produit et les dommages qui en résultent ne pourront être pris en charge par la garantie.

NL Voor inbouw beslist in acht nemen!

- Bad voor het inbouwen op juistheid, beschadigingen en toebehoren op volledigheid controleren.
- **Bij zichtbare beschadiging product in geen geval inbouwen!**
- **Let u bij het gebruik om het gedeeltelijk grote gewicht en/of de grote afmetingen van enkele onderdelen!**
- **bij het boren van gaten er op letten, dat U geen leidingen (elektro, gas of water) beschadigt!**

Wanneer het bad betegeld wordt, beslist de inbouwmaten van de badkuip en van de doucheafscheiding in acht nemen. Onze aansprakelijkheid is beperkt tot onze producten en kan daarom niet op de in- en uitbouw uitgebreid worden. De kosten voor een latere uit- en inbouw van een product en de daaruit voortvloeiende schade zijn geen onderdeel van de garantie.

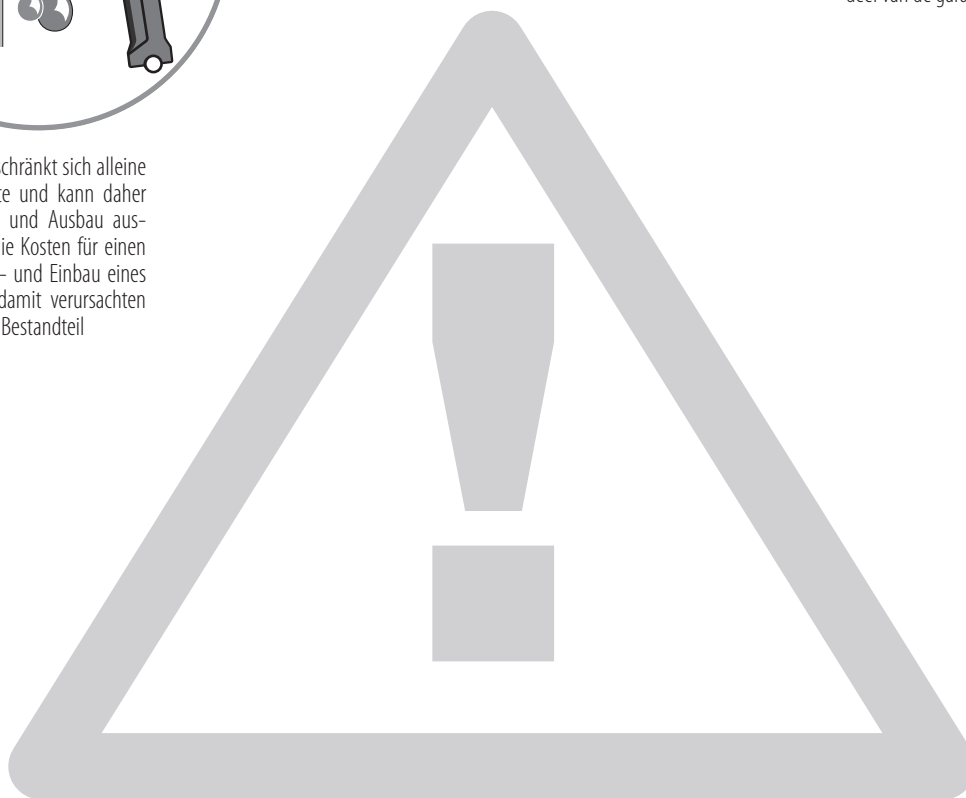



DE ACHTUNG!
Beim Hantieren
mit Glas Schutz-
kleidung tragen!

Bitte untersuchen Sie nach dem Auspacken das Einscheiben-Sicherheitsglas (ESG) unverzüglich auf mögliche Transportschäden, wie abgesprungene Kanten oder Ecken. Wird ein Schaden festgestellt bitte umgehend Schadensmeldung machen und die Scheibe nicht einbauen, da dieser Fehler auch später zu einem Bruch führen kann! Alle Gläser werden vor dem Verpacken sorgfältigst kontrolliert. Spätere Reklamationen, auch bei Bruch, können daher nicht anerkannt werden.

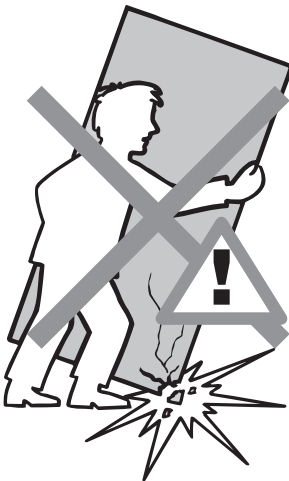

EN ATTENTION!
Wear protective
clothing when
handling glass!

Please examine the single-pane safety glass for possible transport damage such as chipped edges or corners immediately after unpacking. If damage is detected do not install the pane because a defect can lead to breakage later! Please make a damage report without delay! All glass panes are controlled with utmost care before packing. Therefore later complaints cannot be acknowledged, even in case of breakage.

FR ATTENTION !
Portez des
vêtements
protecteurs en
manipulant du
verre.

Merci de vérifier immédiatement le verre de sécurité monofeuille au déballage sur d'éventuels dommages survenus au transport, tels que chants et angles écaillés. Si toutefois un défaut a été constaté, merci d'en faire la déclaration au plus vite et ne pas monter la vitre, car ce défaut peut être, par la suite, à

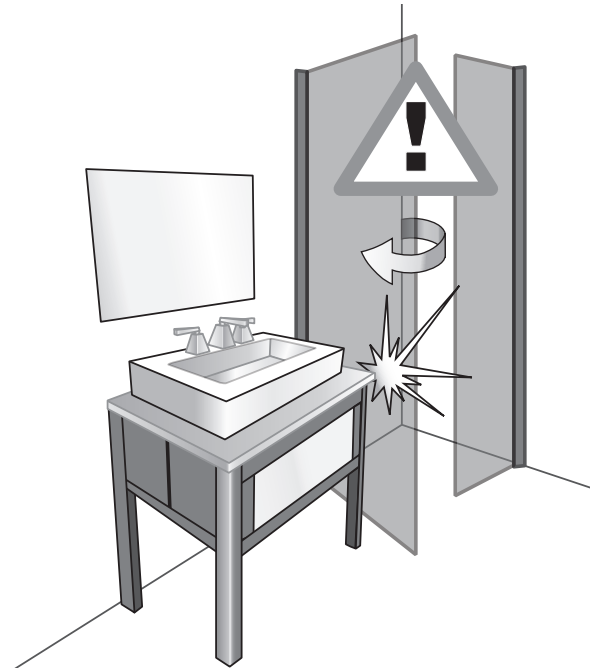

l'origine d'une casse! Tous les verres sont contrôlés minutieusement avant le conditionnement. Pour cette raison, aucune réclamation ultérieure, même en cas de casse, ne pourra être prise en compte.

Na het uitpakken het enkel veiligheidsglas (ESG) onmiddellijk op mogelijke transport- beschadigingen, zoals afgesprongen kanten of hoeken, controleren. Wordt een beschadiging vastgesteld, dan mag het glas niet worden ingebouwd, omdat deze schade ook later tot een breuk kan leiden !Bij een vastgestelde schade, meldt dit onmiddellijk! Al het glas wordt voor het verpakken zorgvuldig gecontroleerd. Latere reclames, ook bij breuk, kunnen daarom niet geaccepteerd worden.

NL ATTENTIE !
Bij het hanteren
van glas be-
schermde kle-
ding dragen!

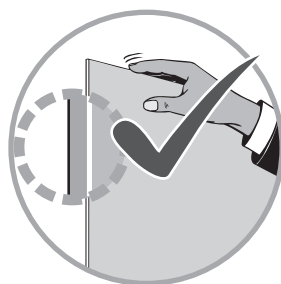
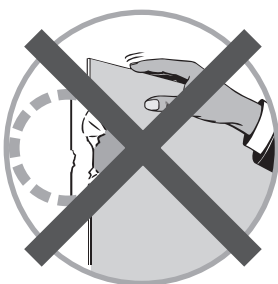









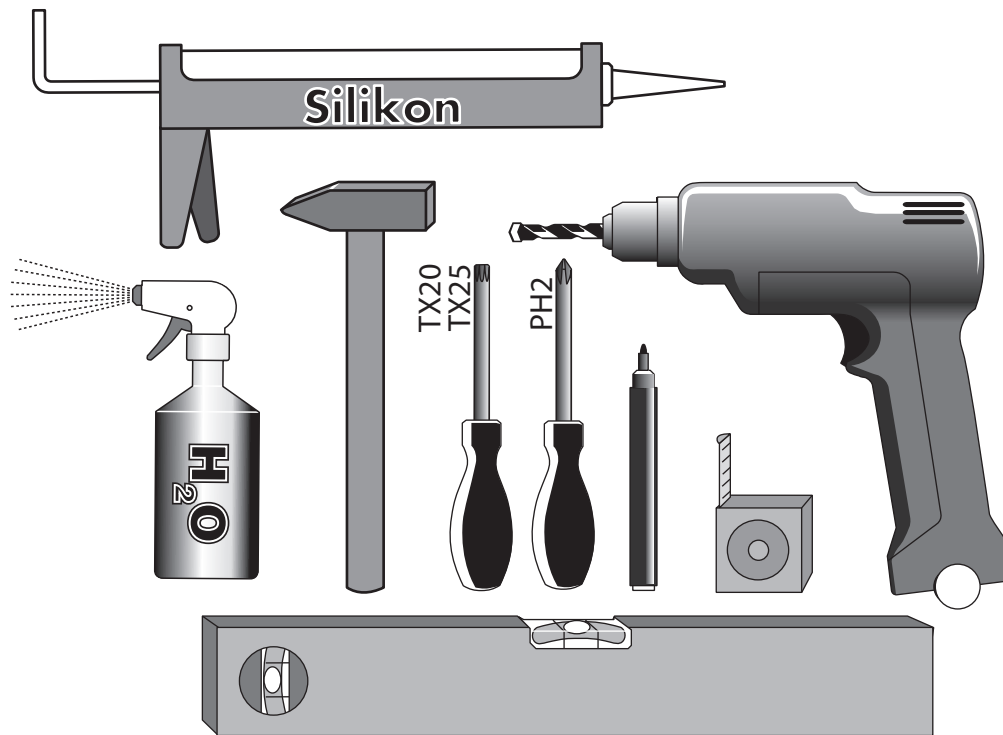



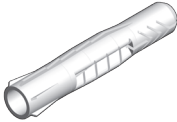



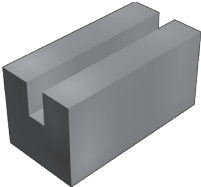
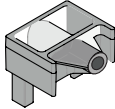

**BENÖTIGTES
WERKZEUG**

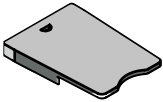
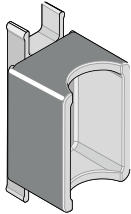
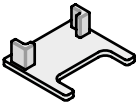
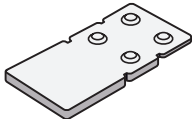
**NECESSARY
TOOLS**

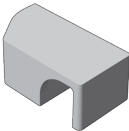
**OUTILLAGE
NECESSAIRE**

**BENODIGD
GEREEDSCHAP**



MONTAGESET	ASSEMBLY KIT	SET DE MONTAGE	MONTAGESET
<p>11 x 4,8 x 60mm MatNr: 24466</p> 	<p>4 x DIN 9021-M5-A2 MatNr: 2494</p> 	<p>10 x Ø 8 x 50 mm MatNr: 24409</p> 	<p>4 x 3,5 x 25mm MatNr: 2418</p> 
<p>1x Ø3 mm MatNr: 18750</p> 	<p>2x MatNr: 18016</p> 	<p>5 x 3,5 x 13 mm MatNr: 2429</p> 	<p>5 x MatNr: 18852 VC</p> 
<p>1x MatNr: 805W17</p>  <p>4cm</p>	<p>1x MatNr: 18853</p> 	<p>1x MatNr: 704209 DG</p> 	<p>1x MatNr: 704210 DG</p> 
<p>1x MatNr: 18926 VC</p> 	<p>1x MatNr: 704207</p> 	<p>4x MatNr: 704208</p> 	<p>1x MatNr: 704205</p> 
<p>2x MatNr: 704520</p> 	<p>1x MatNr: 18815</p> 	<p>1x MatNr: 18816</p> 	<p>1x MatNr: 704203</p> 
<p>6 x DIN 125-M5-A2 MatNr: 2430</p> 	<p>1 x MatNr: 18814</p> 	<p>2 x Ø 6 x 30 mm MatNr: 24410</p> 	<p>2 x 4,2 x 38mm MatNr: 24200</p> 

MONTAGE VARIANTEN	ASSEMBLY VARIATIONS	VARIANTES DE MONTAGE	MONTAGE VARIANTEN
-------------------	---------------------	----------------------	-------------------

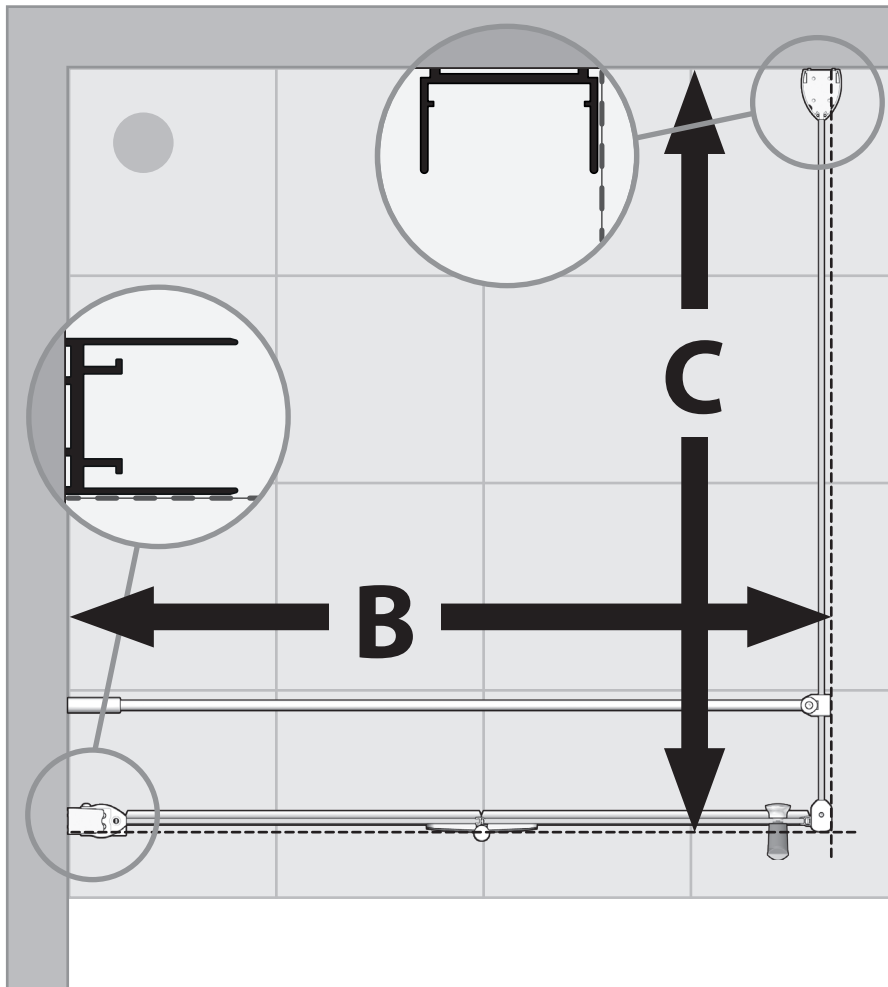

DE Montage ohne Duschwanne.

EN Assembly without shower tray.

FR Montage sans receveur de douche.

NL Montage zonder douchebak.

VERSTELLBEREICH	ADJUSTMENT RANGE	POSITIONNEMENT	VERSTELBAARHEID
-----------------	------------------	----------------	-----------------

Auftrag Nr.:		Serie	B	C
Sondergrößen • special sizes • mesures spéciales • speciale maten		80	77,5 ± 0,9 cm	77,5 ± 0,9 cm
B=	cm	90	87,5 ± 0,9 cm	87,5 ± 0,9 cm
C=	cm	100	97,5 ± 0,9 cm	97,5 ± 0,9 cm
		120	117,5 ± 0,9 cm	117,5 ± 0,9 cm

MONTAGE VARIANTEN	ASSEMBLY VARIATIONS	VARIANTES DE MONTAGE	MONTAGE VARIANTEN
-------------------	---------------------	----------------------	-------------------

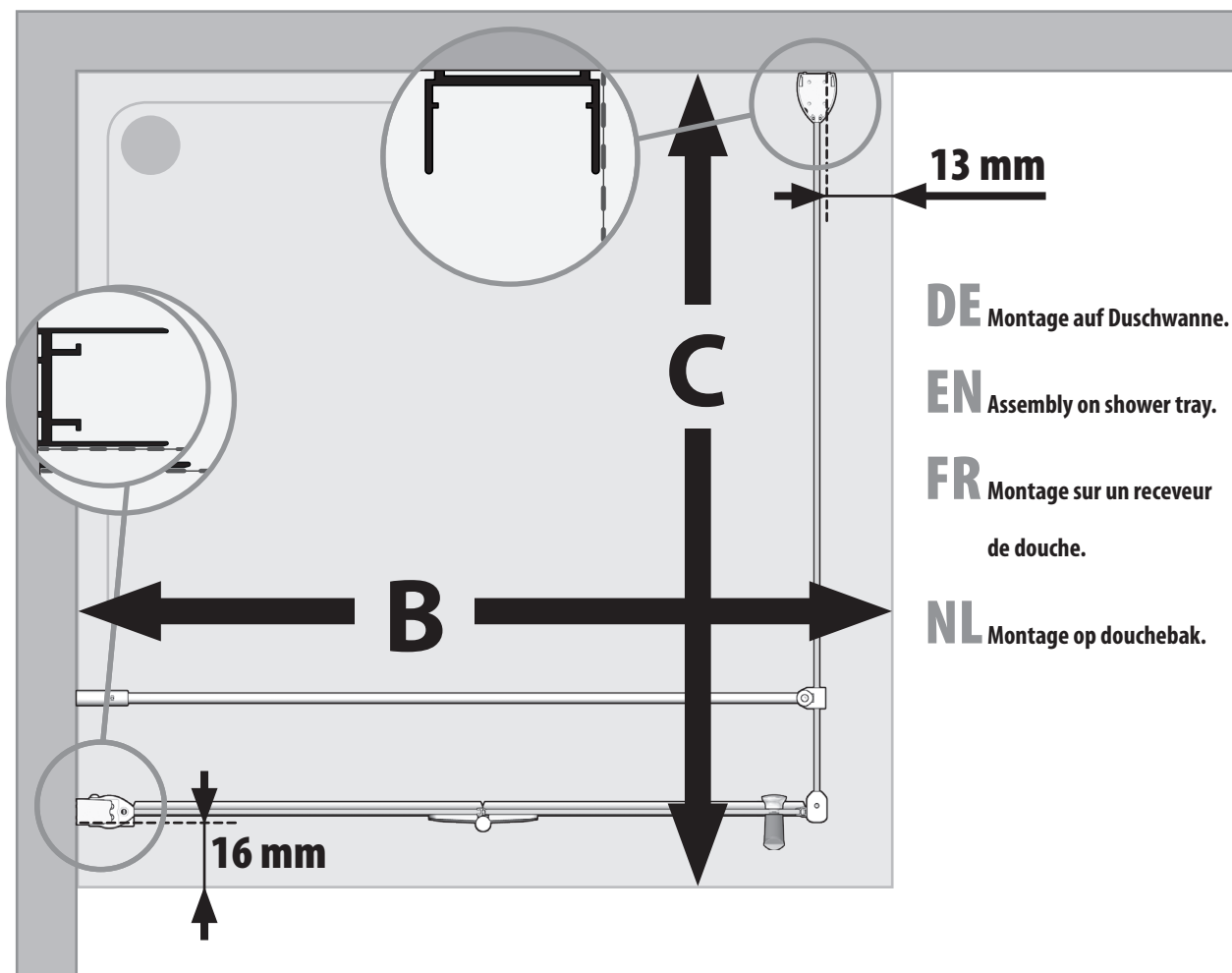

WANNEN EINBAUMASS	TRAY INSTALLATION MEASUREMENT	MESURES POUR MONTAGE SUR RECEVEUR	DOUCHEBAK INBOUWMAAT
-------------------	-------------------------------	-----------------------------------	----------------------

Serie	B	C
80	78,2 - 80 cm	78,2 - 80 cm
90	88,2 - 90 cm	88,2 - 90 cm
100	98,2 - 100 cm	98,2 - 100 cm
120	118,2 - 120 cm	118,2 - 120 cm

1

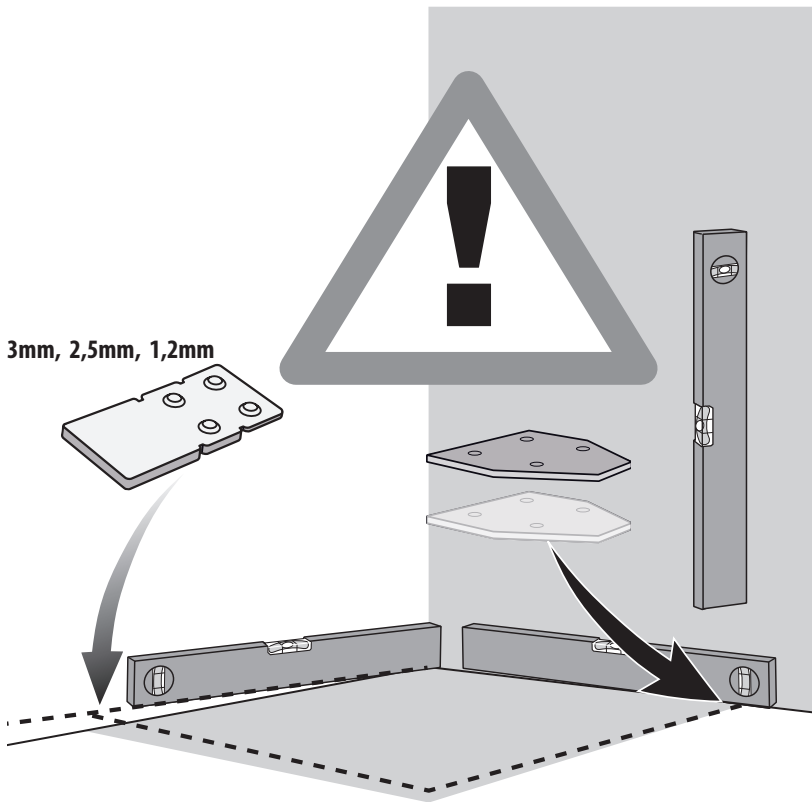

DE **Achtung: Prüfen Sie vor Beginn der Montage die Größe Ihrer Duschtrennung**

Eine **einwandfreie** Montage ist nur möglich wenn der Boden **waagrecht** und die Wände **senkrecht** sind.

EN **Attention: Before assembly check the size of your shower enclosure**

Correct installation is only possible if the floor is horizontal and the walls are vertical.

FR **Attention: Avant de débiter le montage, contrôlez la dimension de votre paroi de douche**

Un montage impeccable n'est possible que si le sol est parfaitement plan et le murs droits.

NL **Let op: controleert u voor montage de grootte van uw douchekomb.**

Een perfecte montage is alleen mogelijk, als de bodem horizontaal en de wanden verticaal t.o.v. elkaar staan.

2

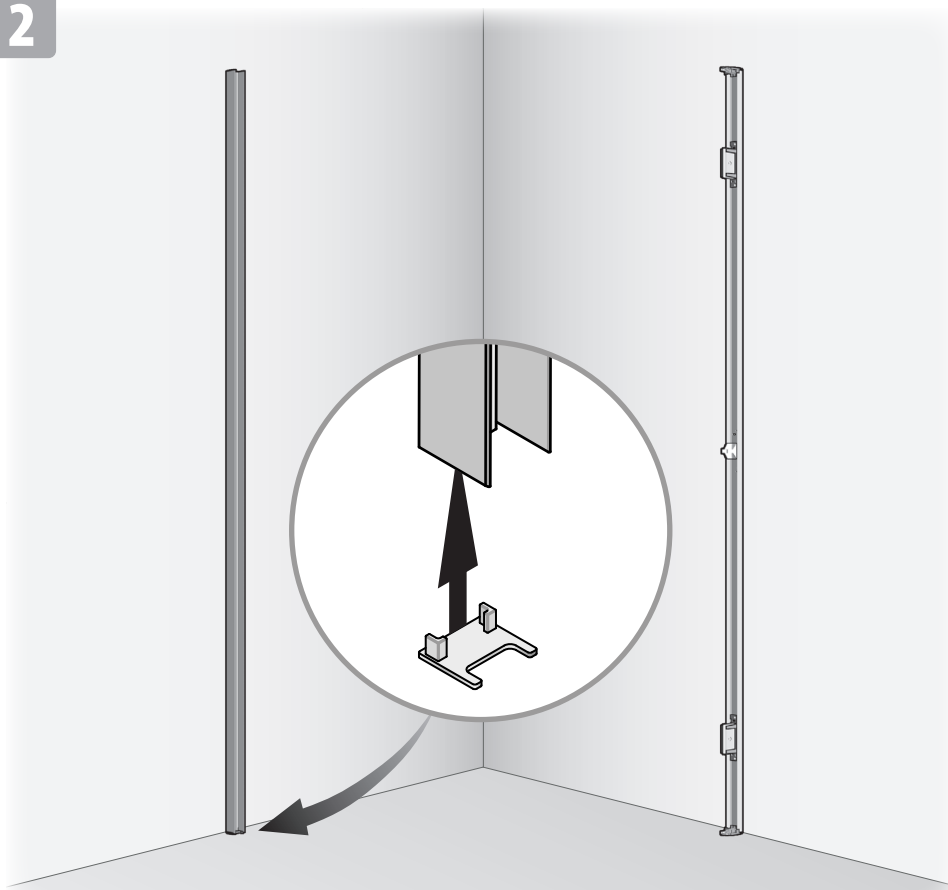

3

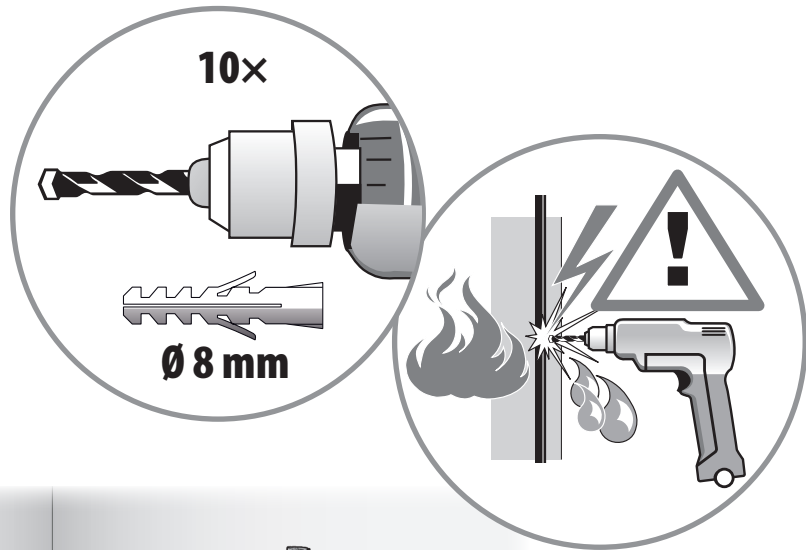

4

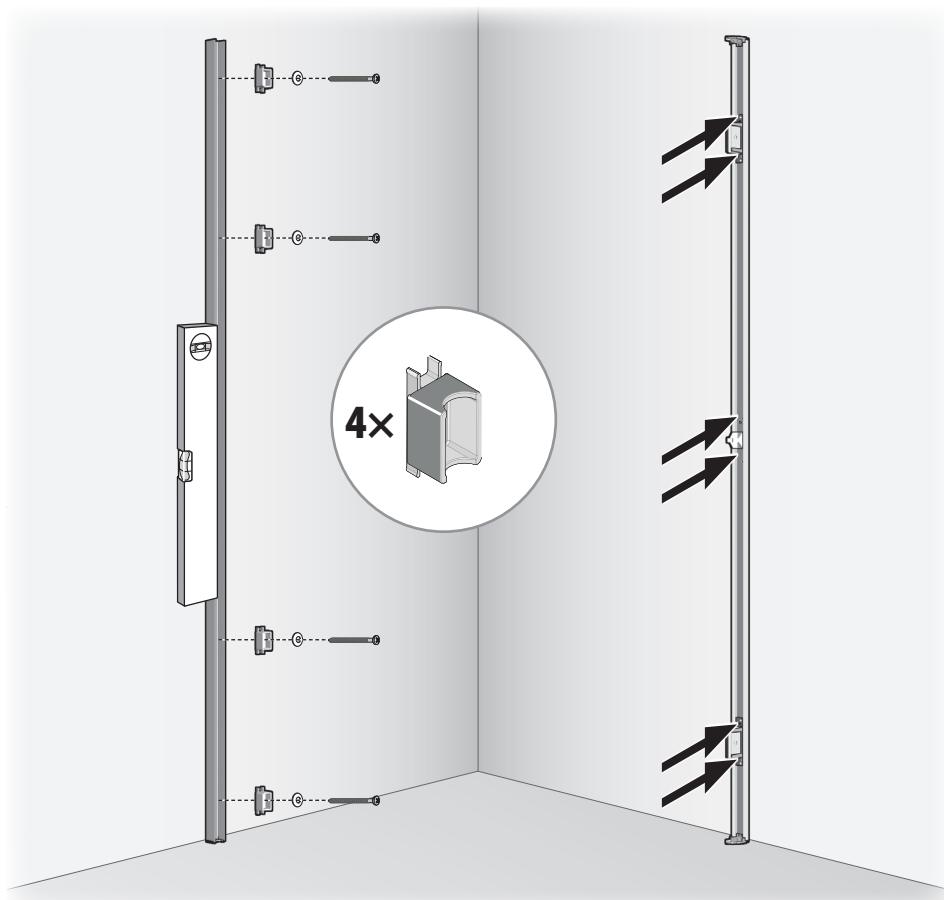
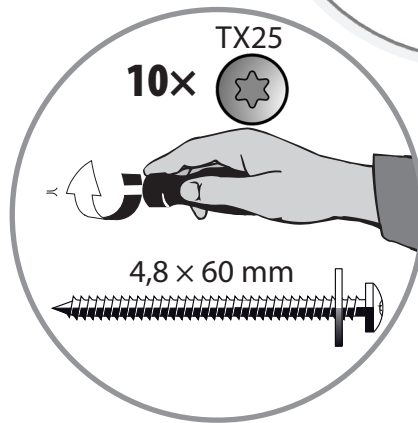
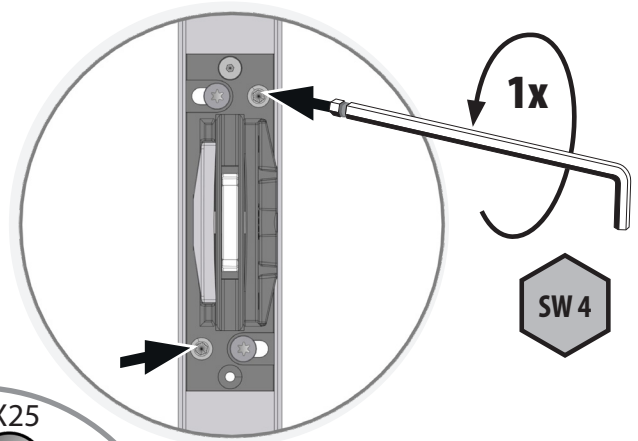

5

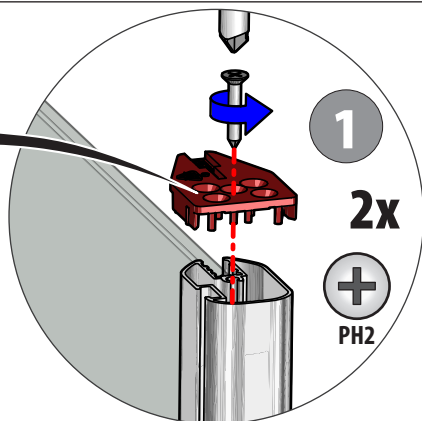

1

2x

+

PH2

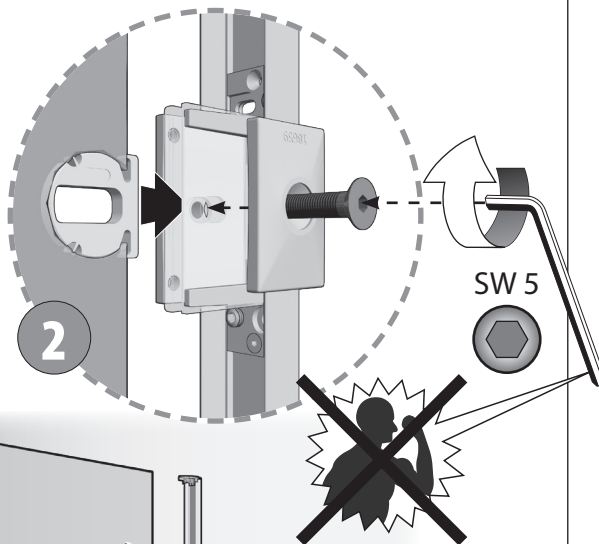

SW 5

2

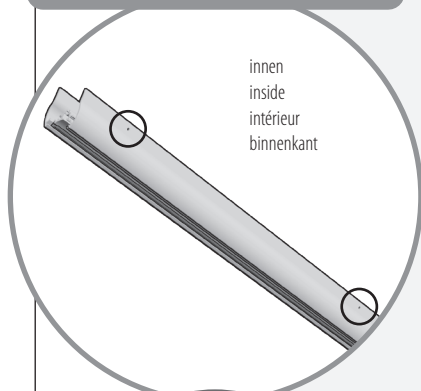

innen
inside
intérieur
binnenkant

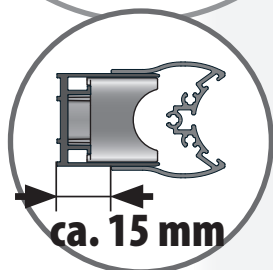

ca. 15 mm



2

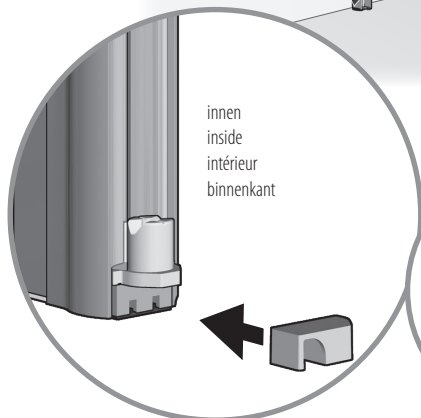

innen
inside
intérieur
binnenkant

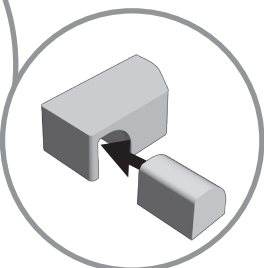

JUSTIEREN	ADJUST	AJUSTER	GOED AFSTELLEN
-----------	--------	---------	----------------

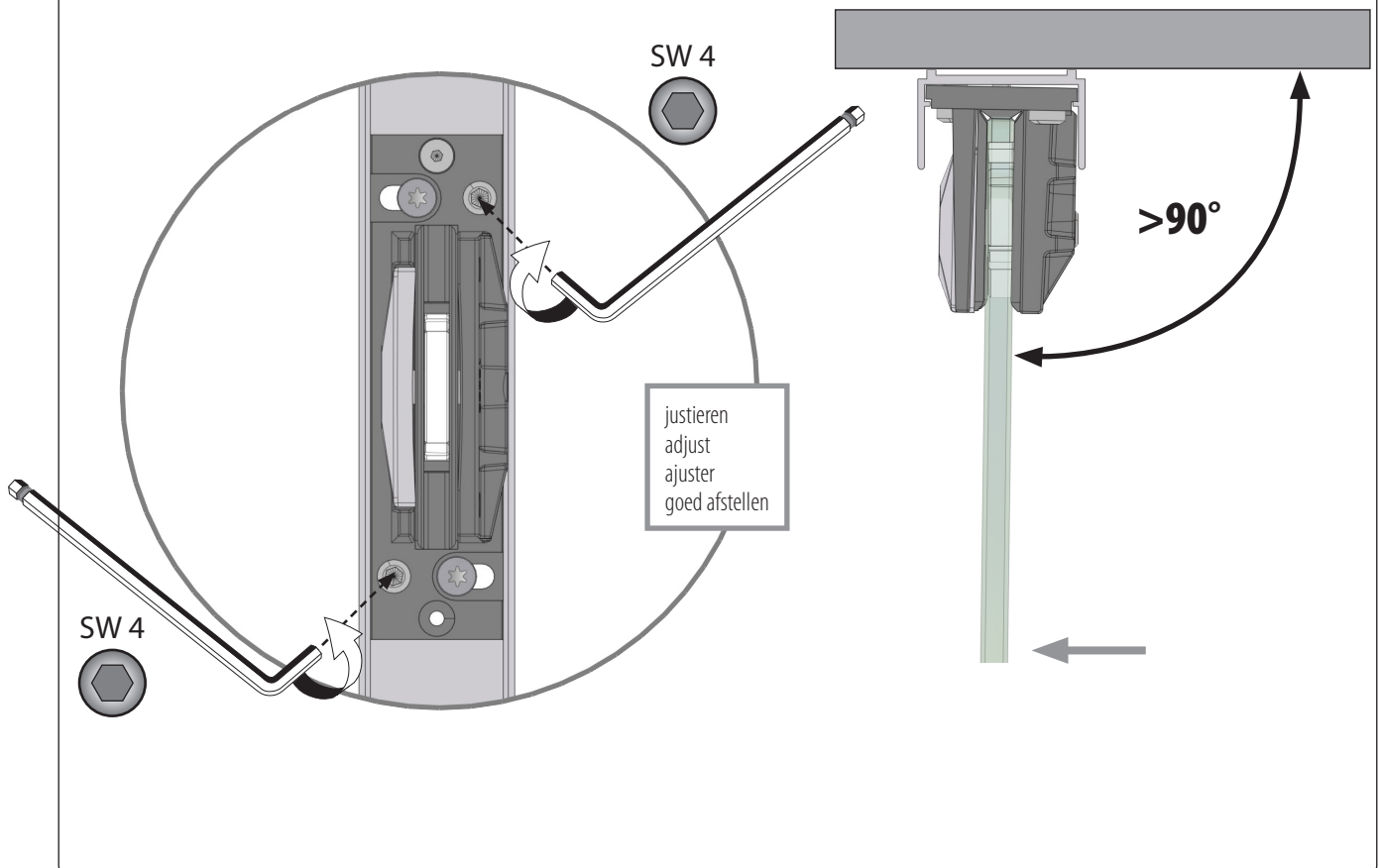
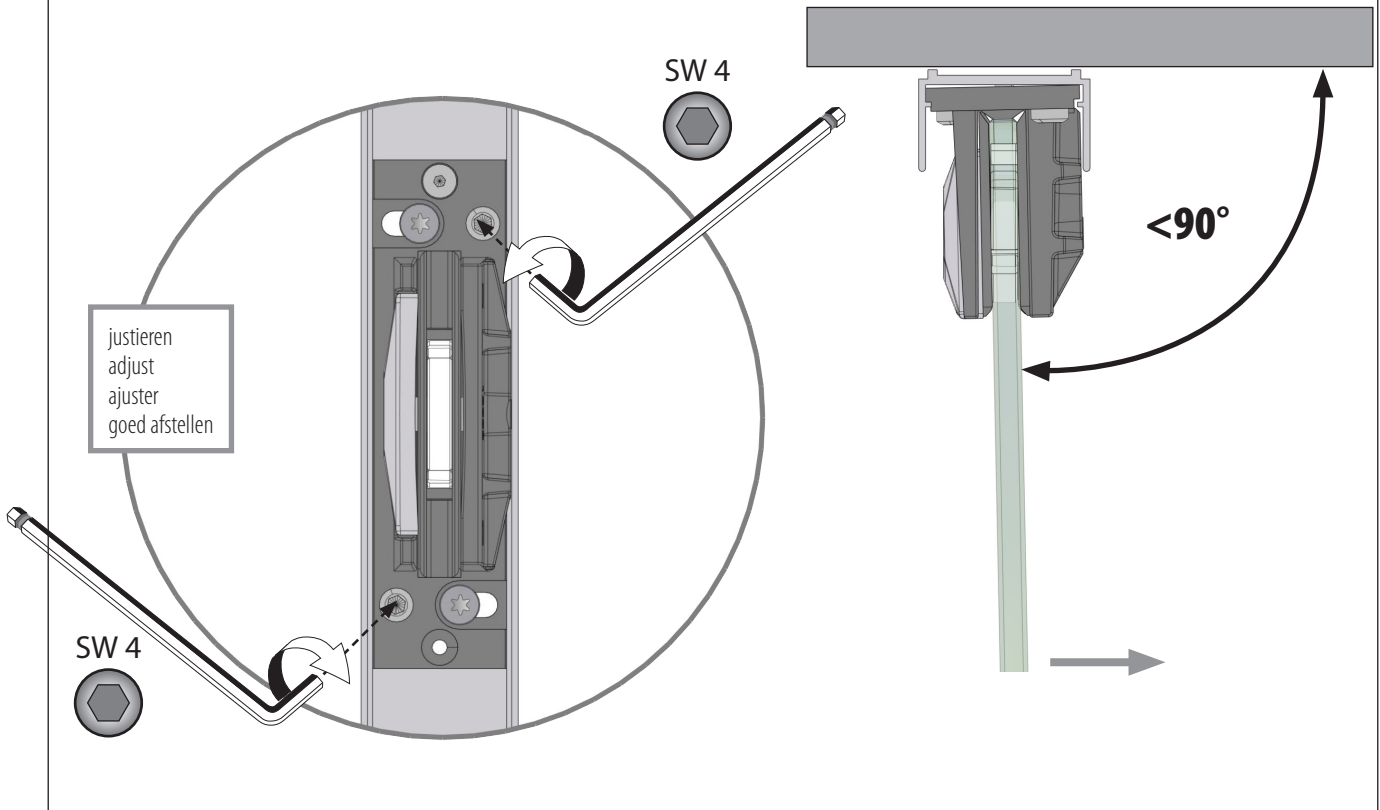

6

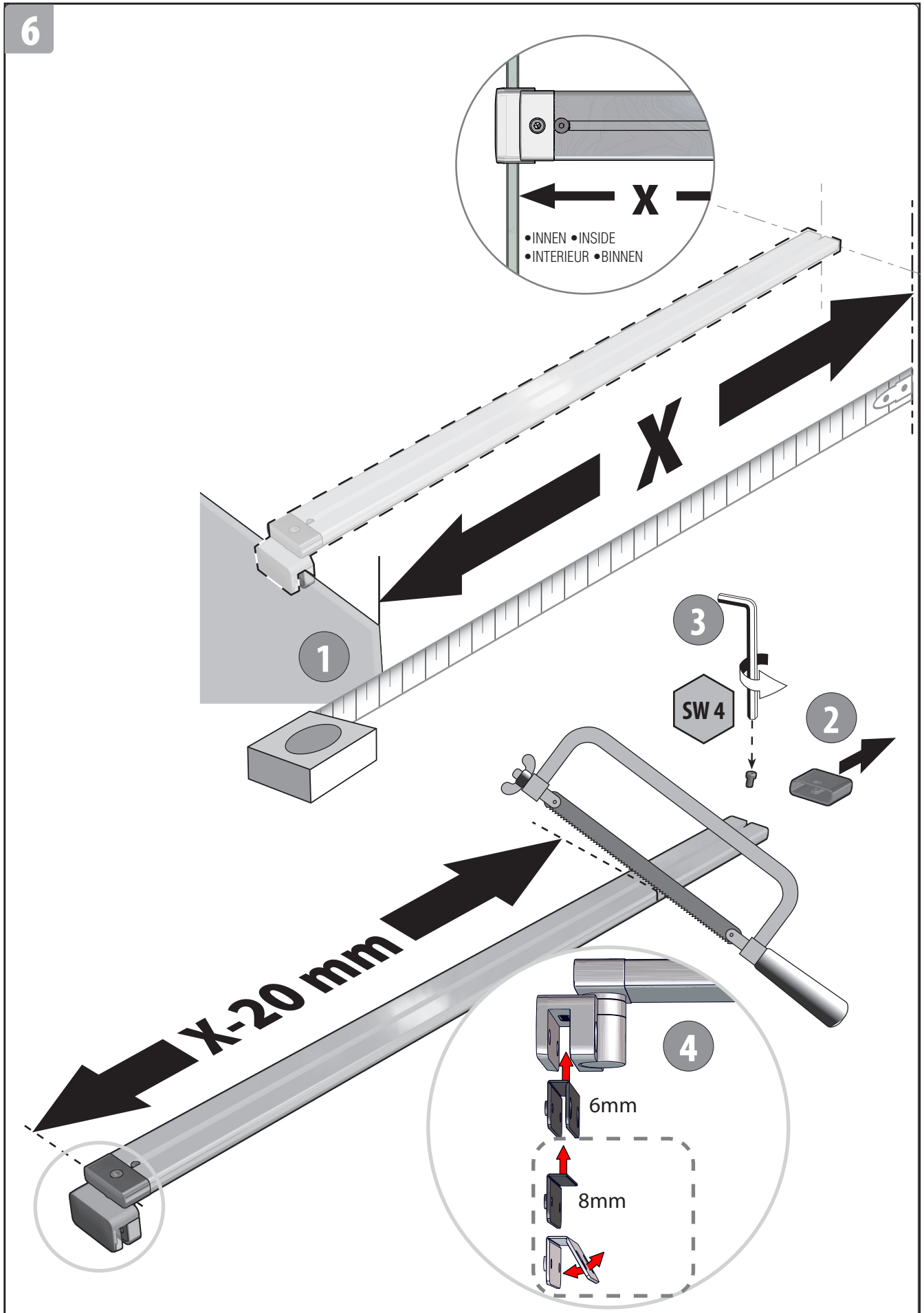

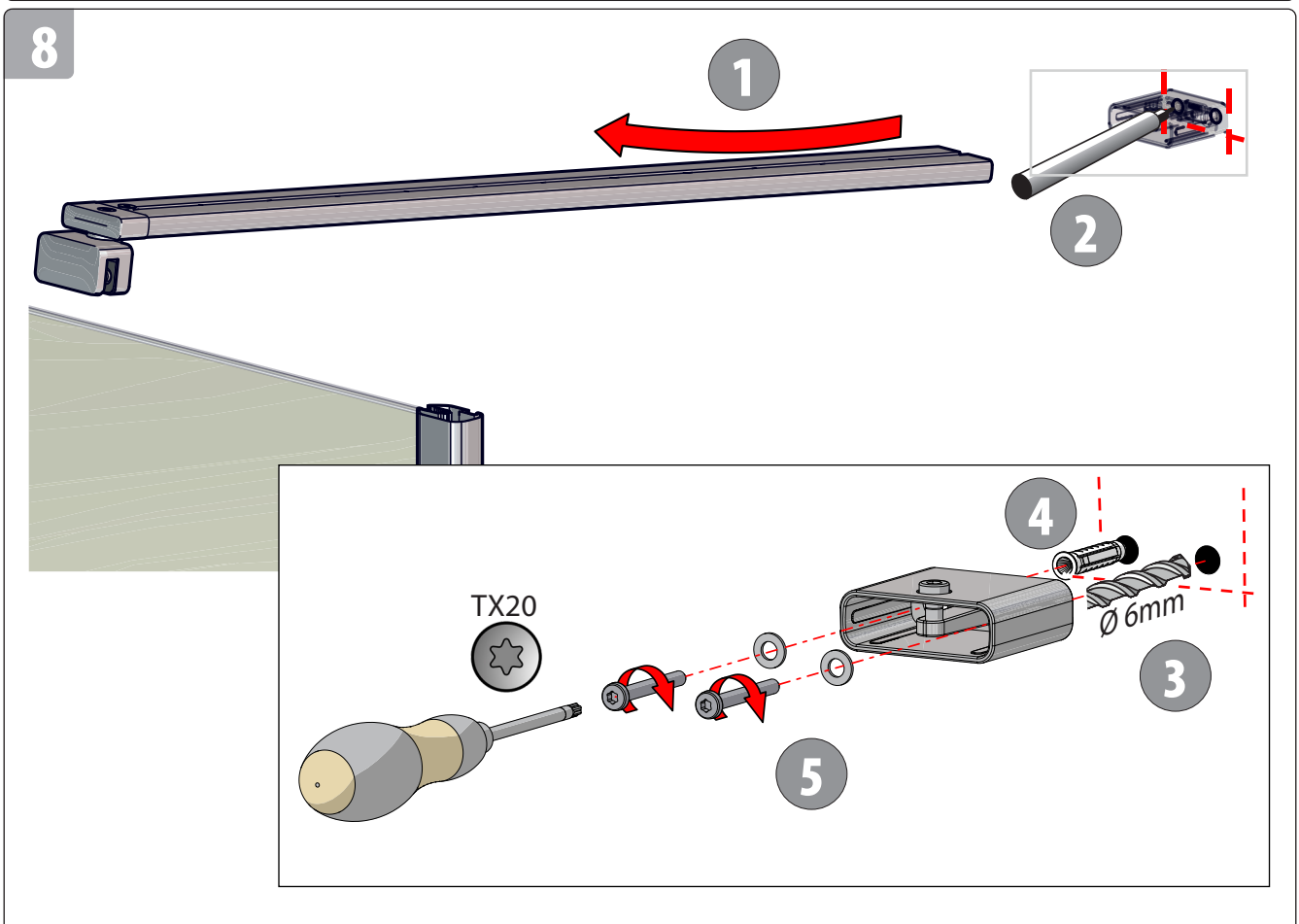
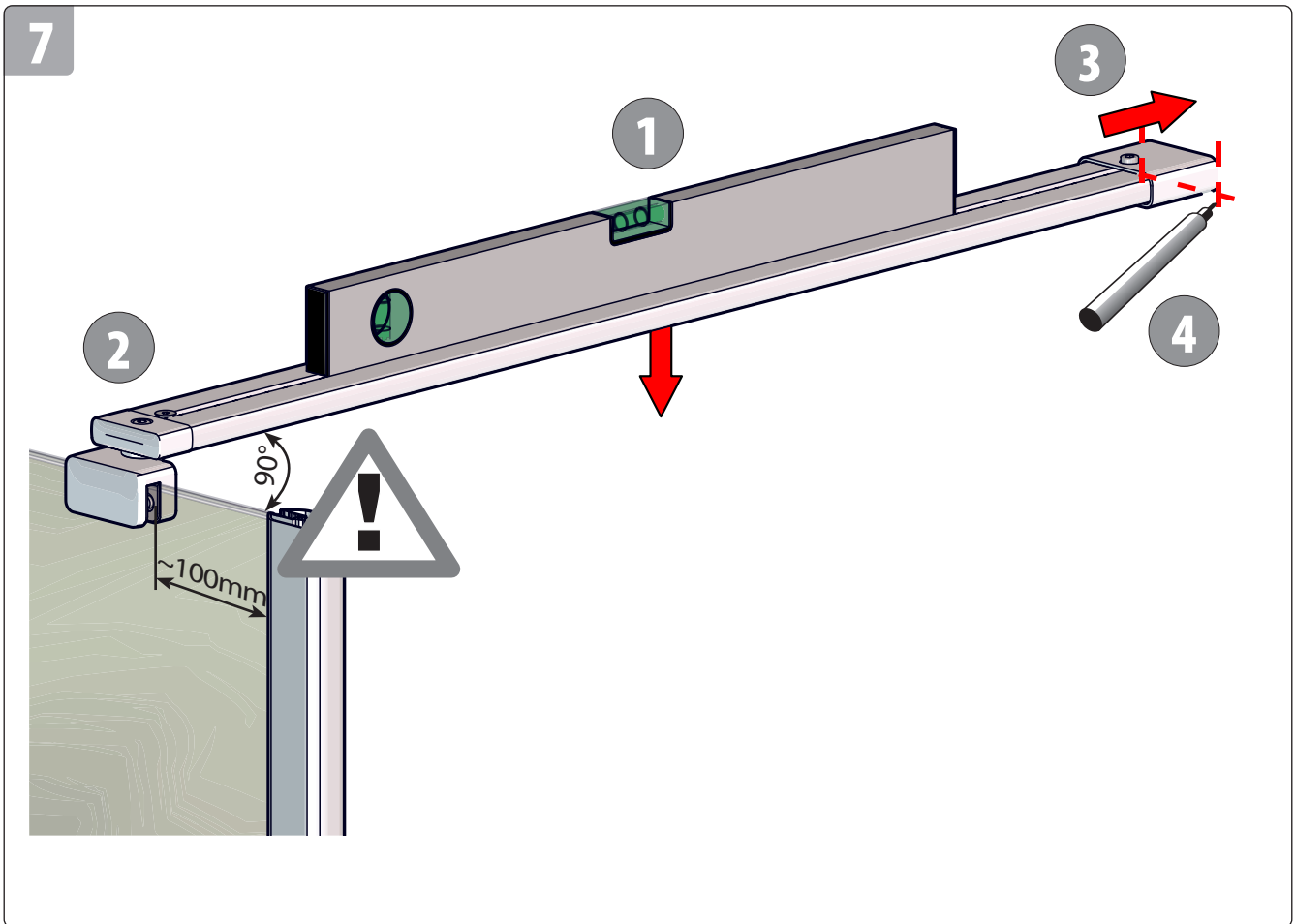

9

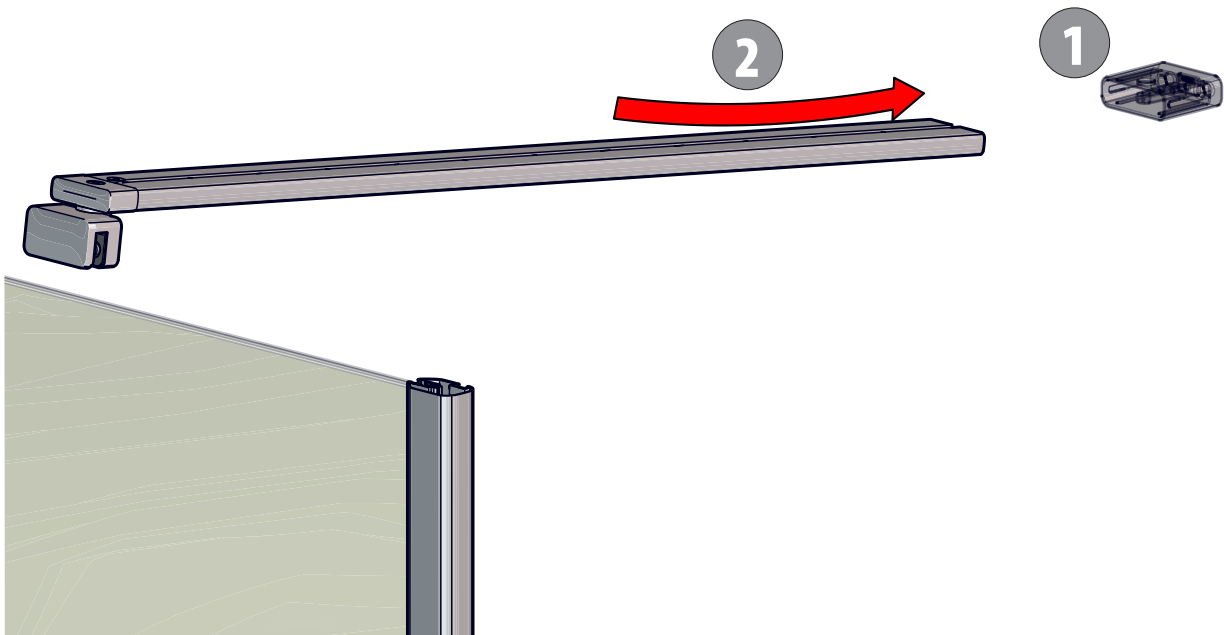

10

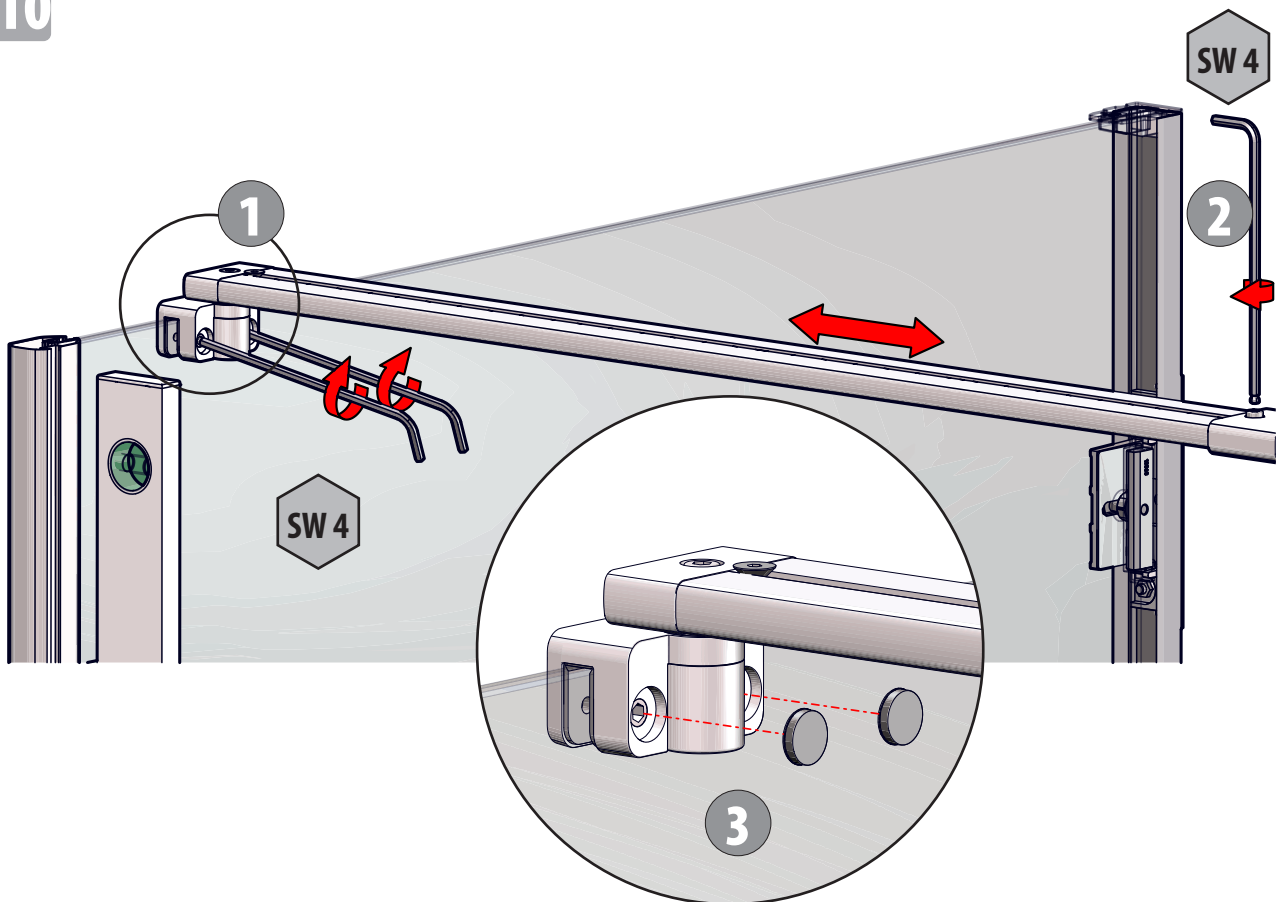

11

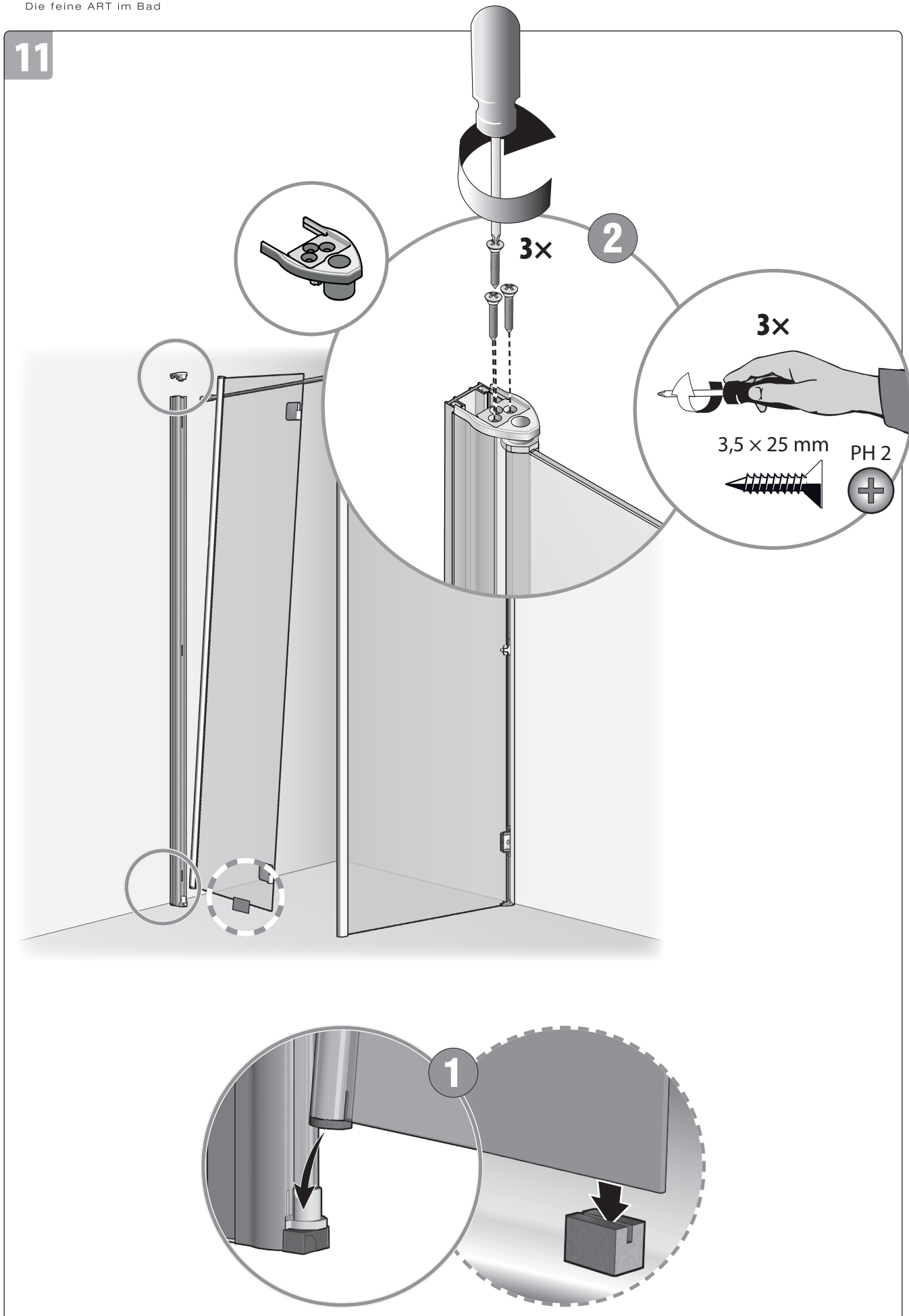

12

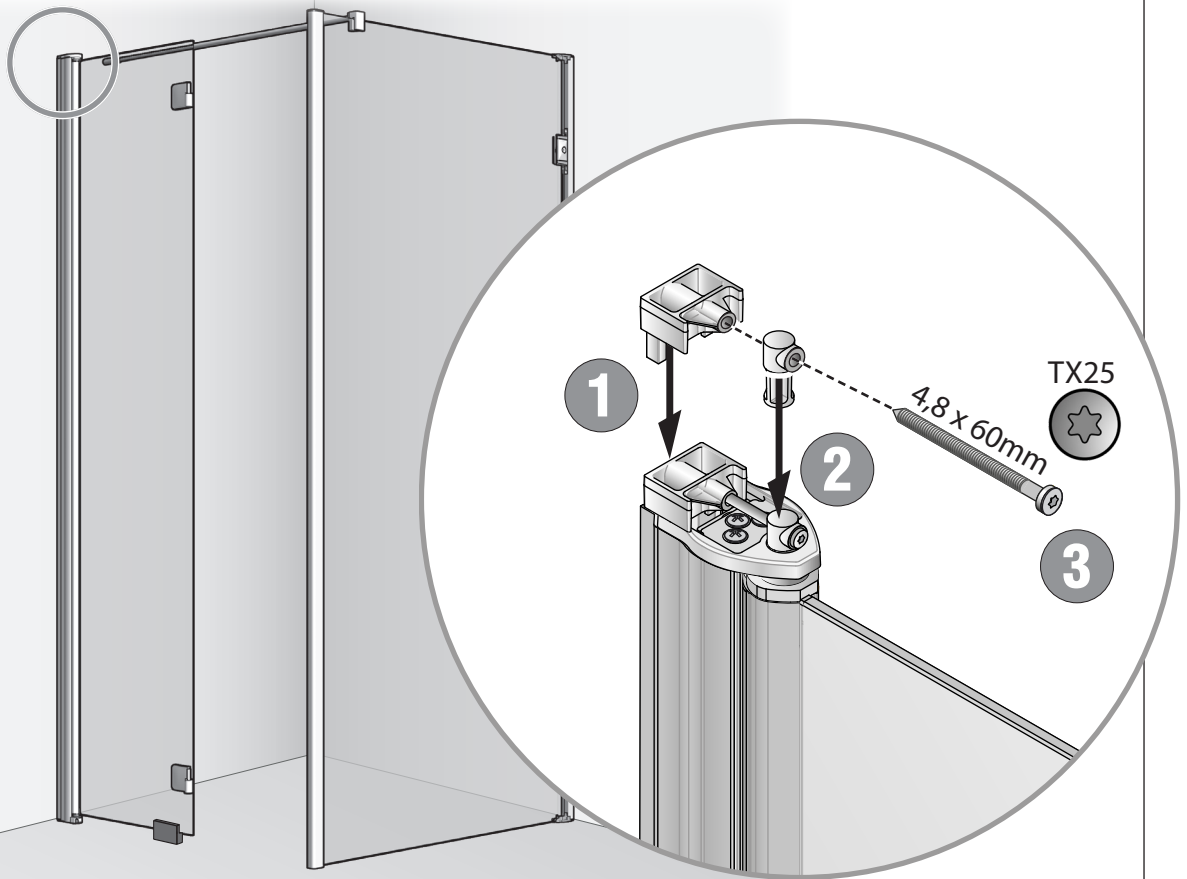

13

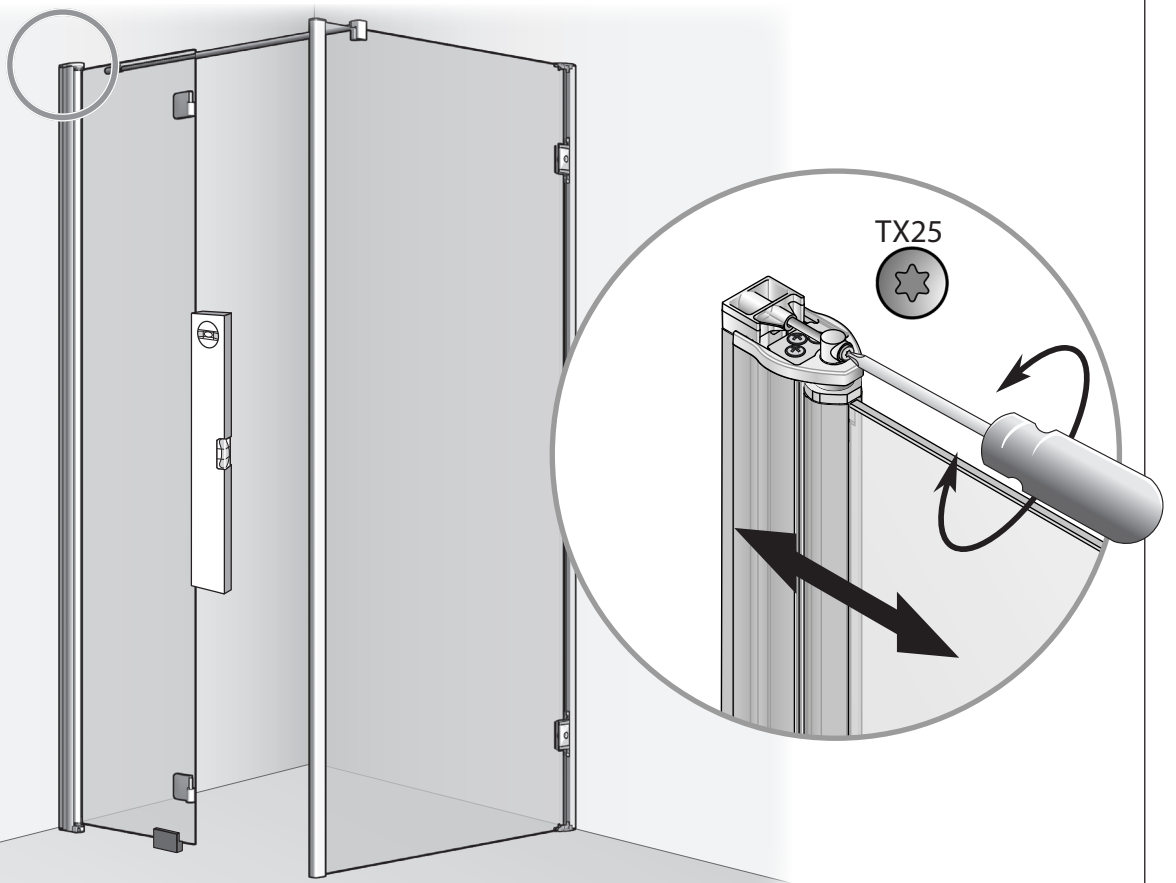

14

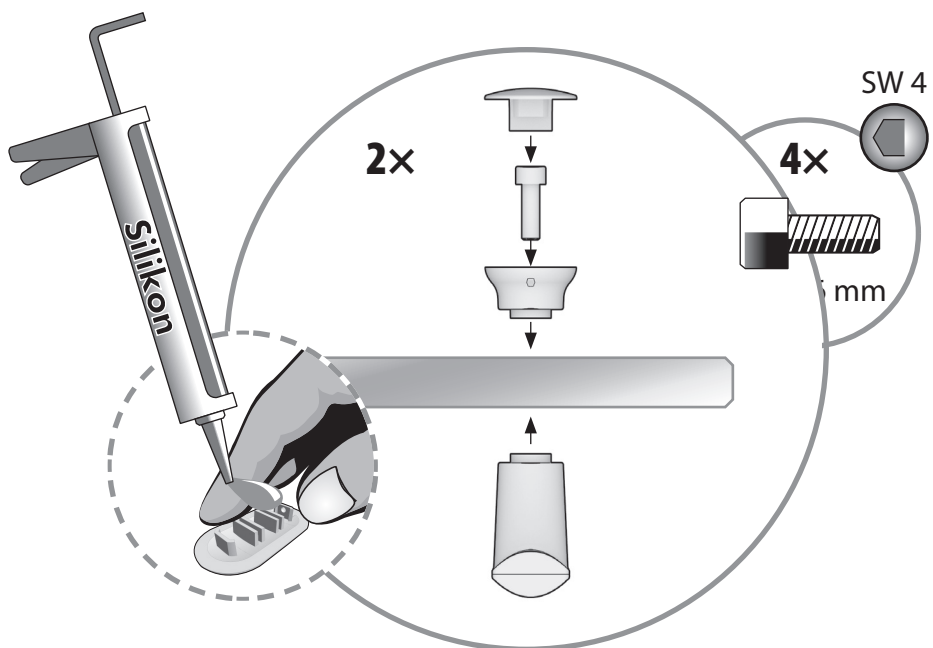
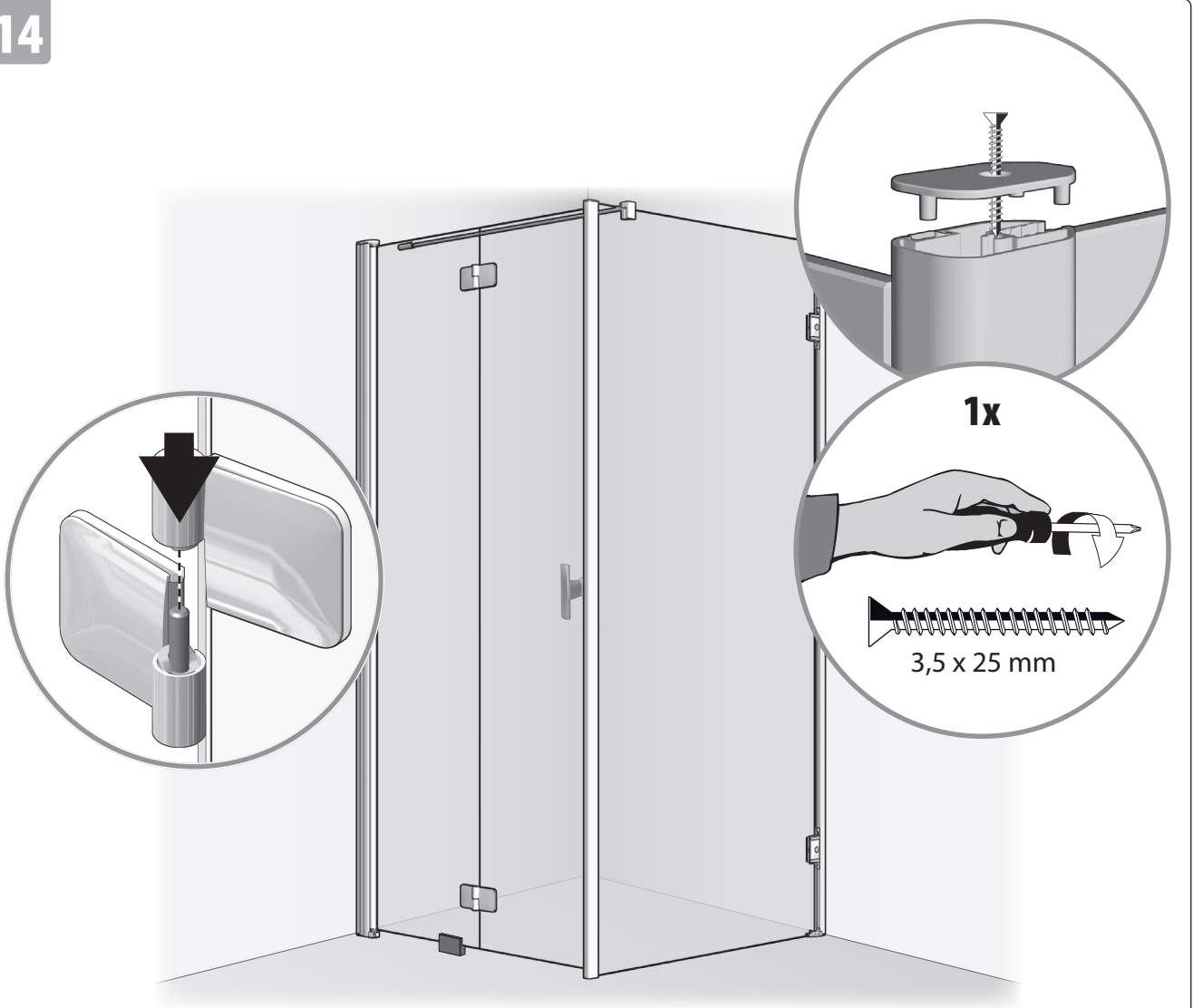

15

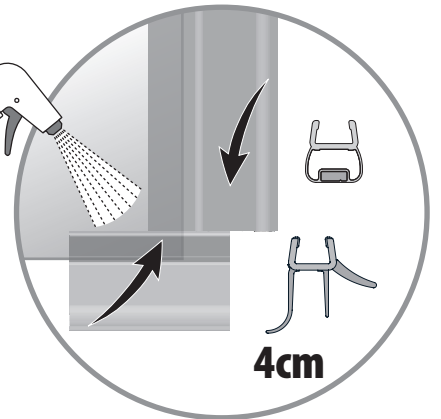
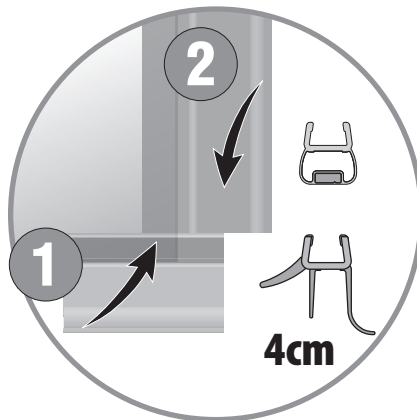
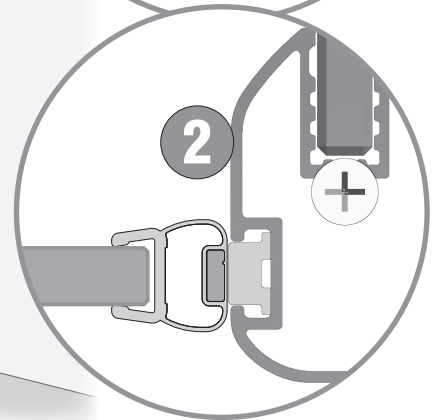
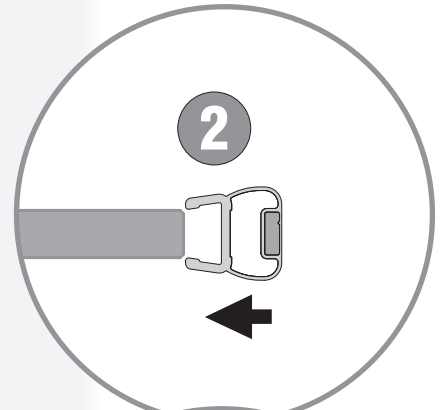

16

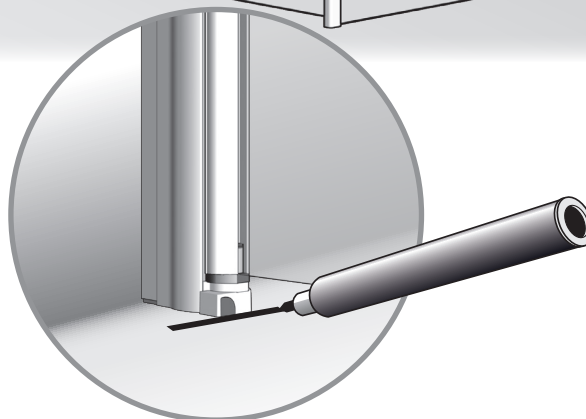
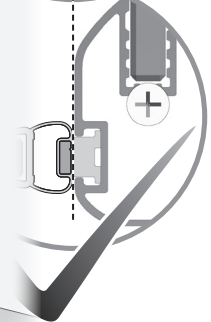
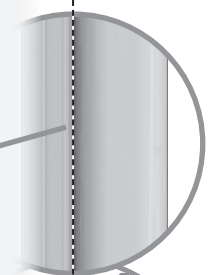
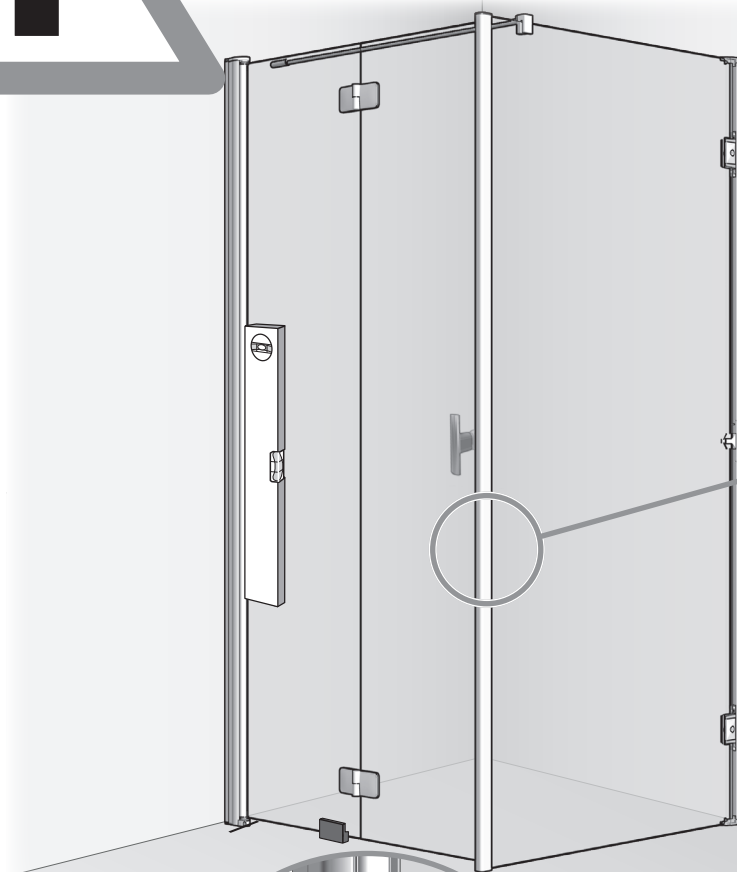
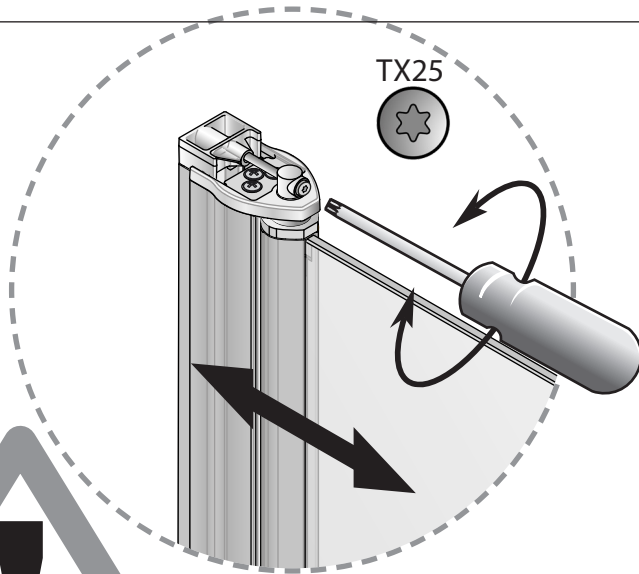

17

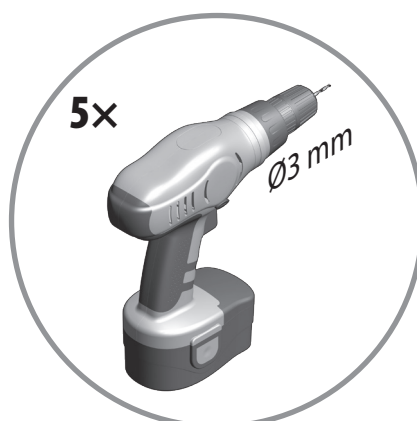
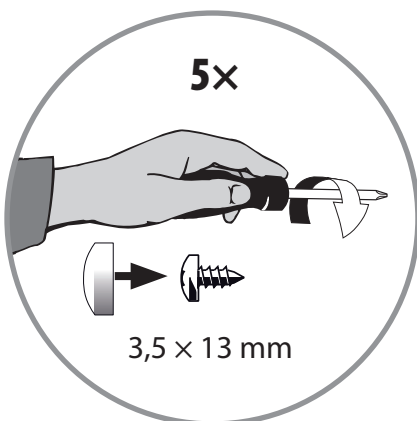
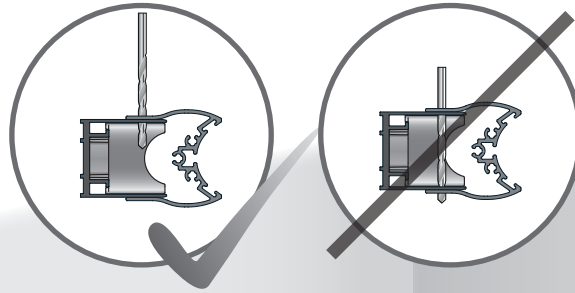

18

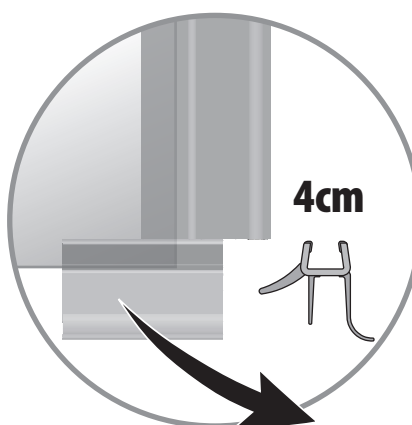
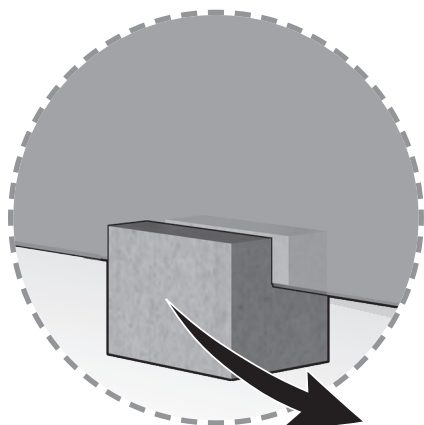
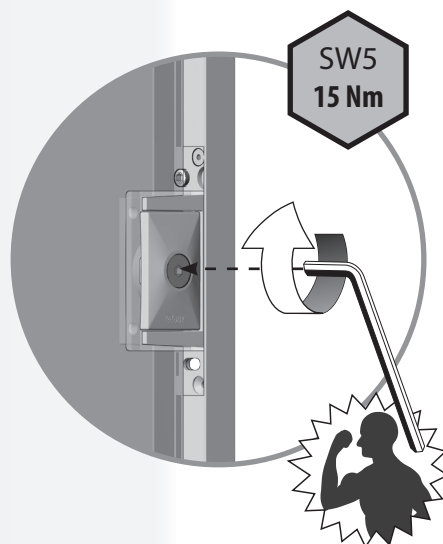
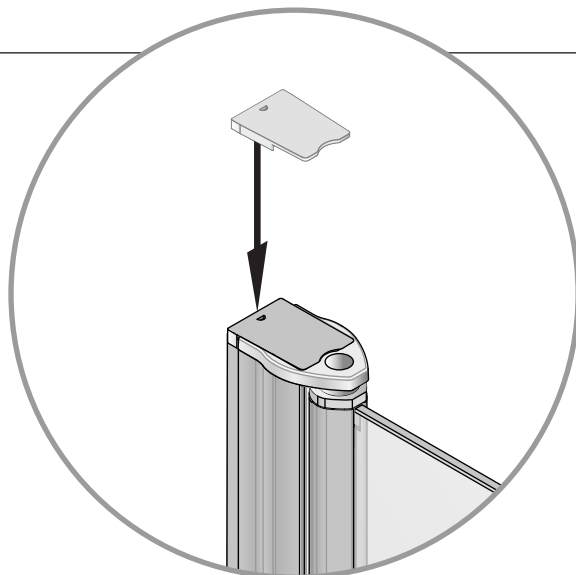
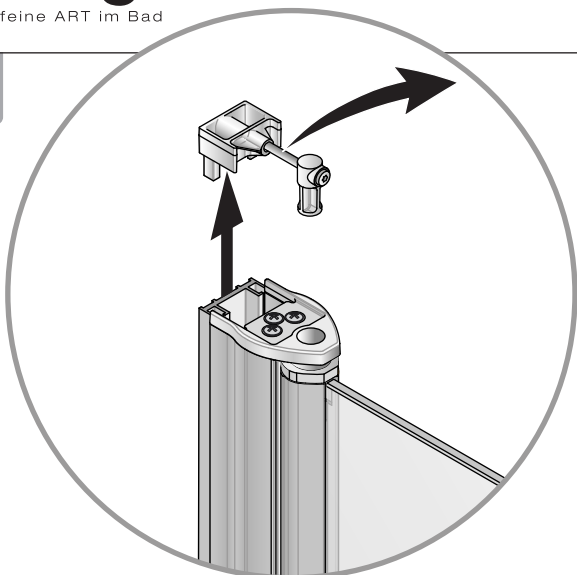

19

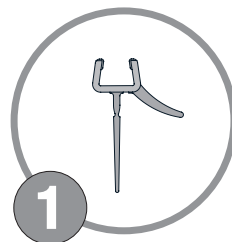
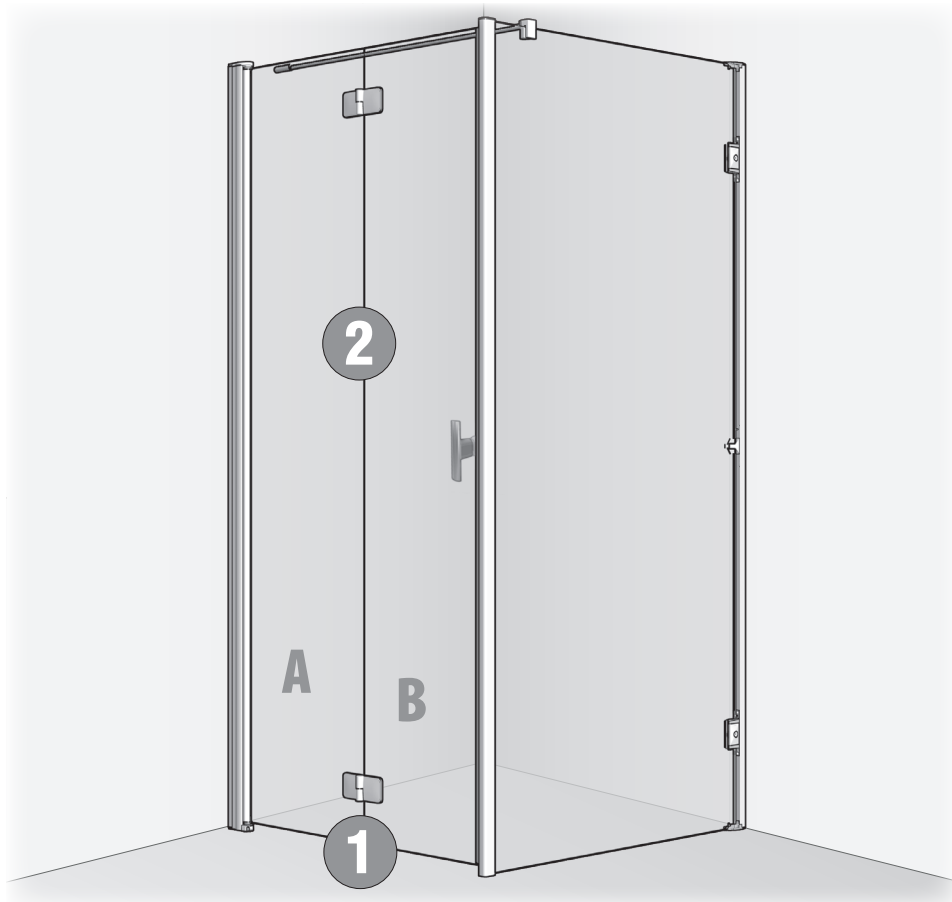
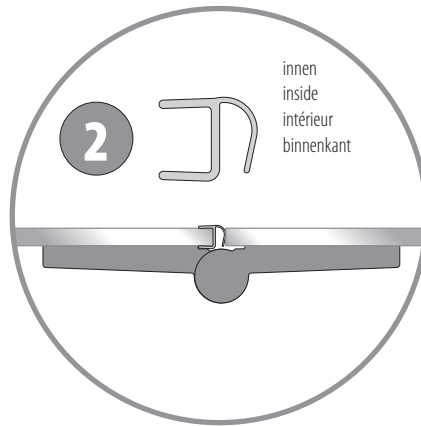

20

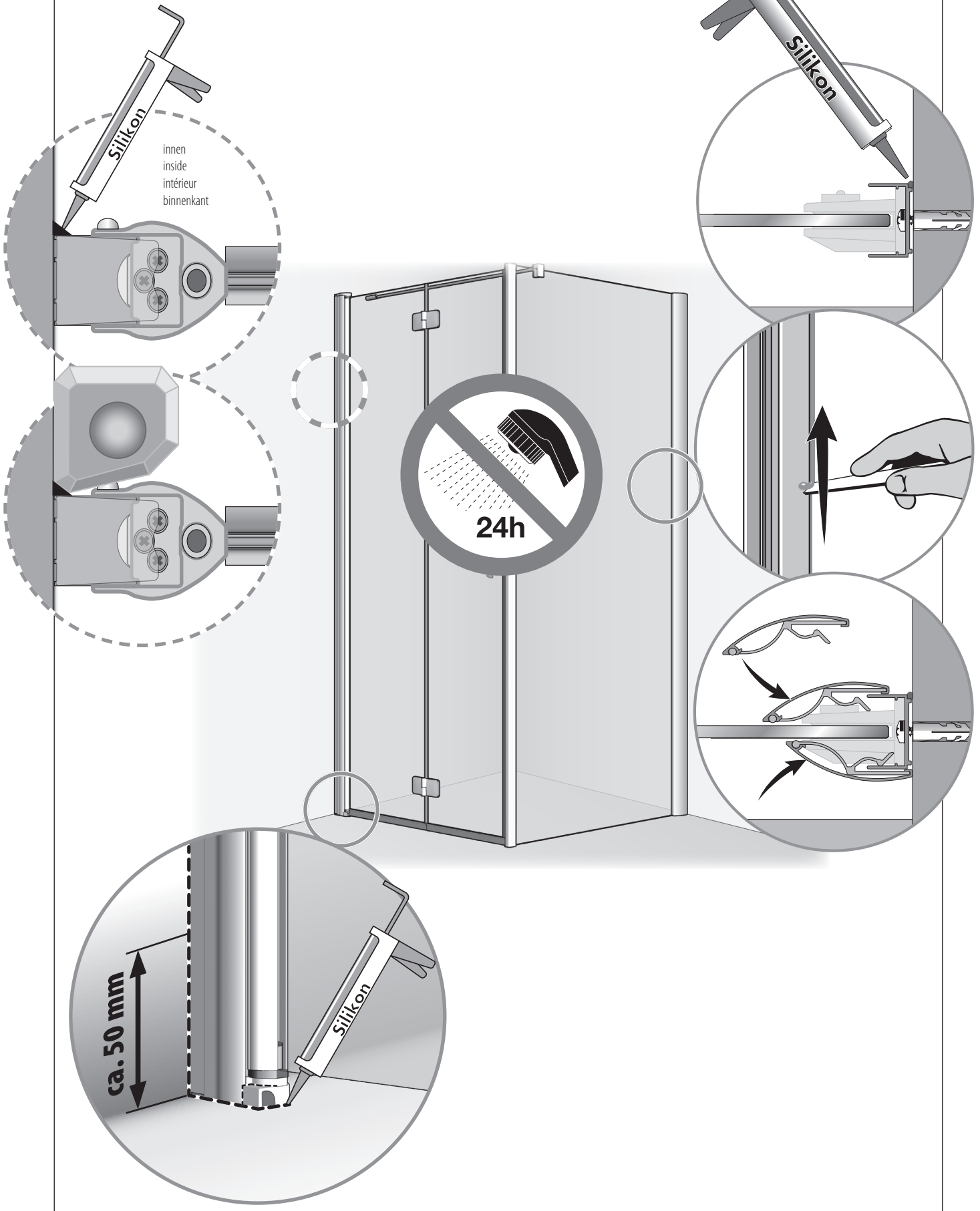

TWISTLINE

2-tlg. Falлтür ohne Fixteil zu Seitenwand

5WZ305

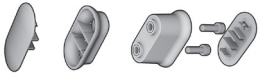

5TZ302

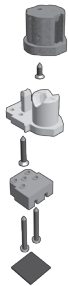

5WZ304



5TZ304

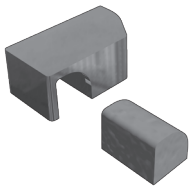

5TZ209



5TZ203



5TZ204



5WZ102 (2x)



5WZ304

5TZ203

5TZ101 (4x)



5WZ303 (5x)



5TZ209

5TZ102



5TZ204

5TZ306 links
5TZ307 rechts

5WZ305

5TZ302

5TZ304

5TZ207
5TZ208

5TZ207



5TZ208

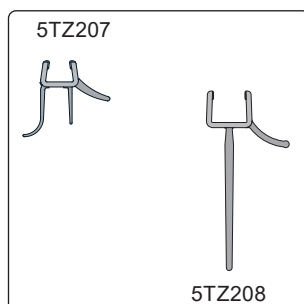
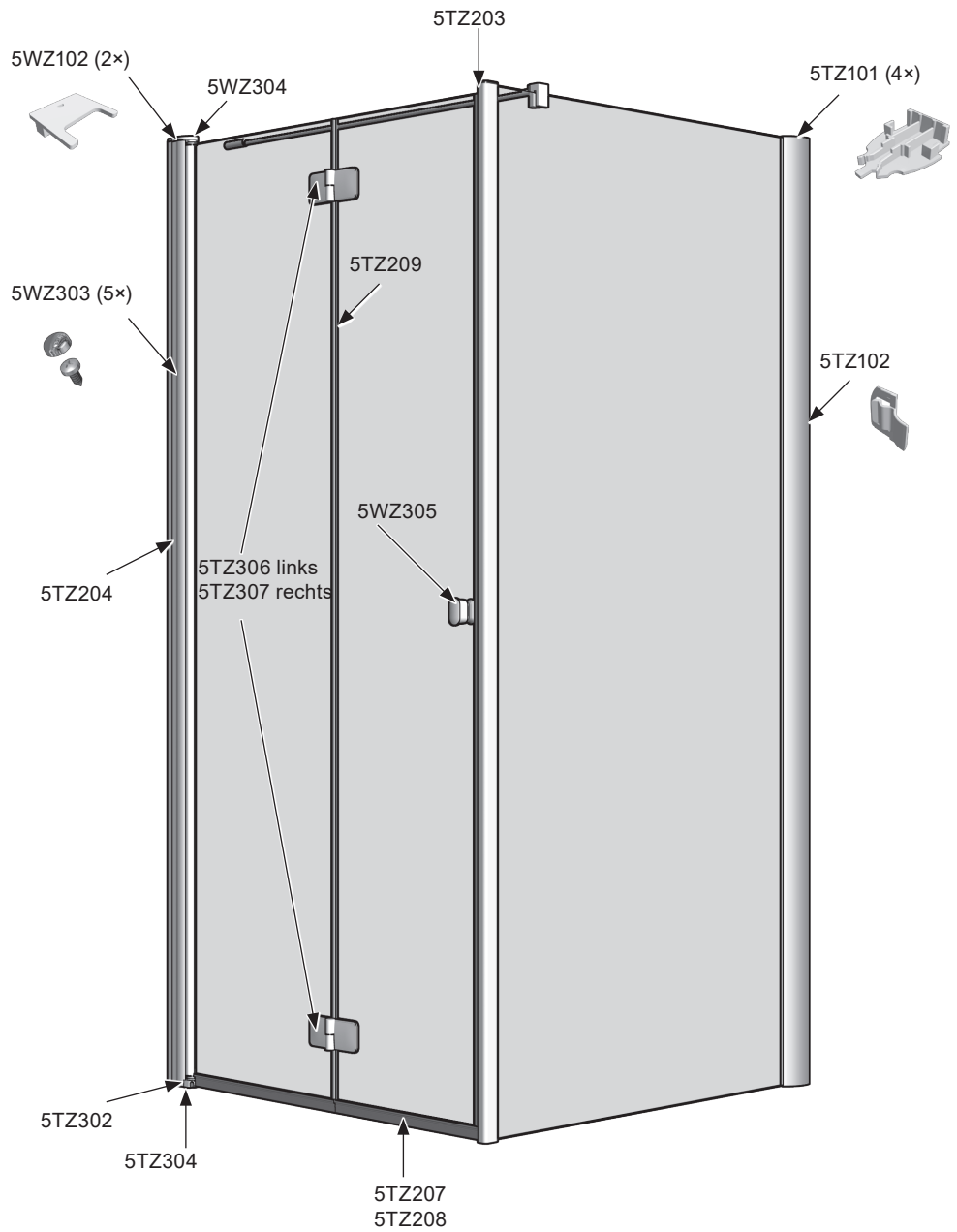
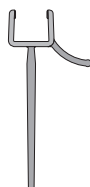

Artweger GmbH. & Co. KG
Sulzbacherstraße 60 | 4820 Bad Ischl | Austria
Tel. +43 6132 205-0 | Fax +43 6132 205-5001
info@artweger.at | www.artweger.at

Verkauf Deutschland
Artweger GmbH. & Co. KG
Postfach 1169 | 83402 Ainring | Deutschland
Tel. 0800 1114442-0 | Fax 0800 1114442-5002
info@artweger.de | www.artweger.de

Verkauf Schweiz
Artweger GmbH. & Co. KG
Postfach 16 | CH-4202 Duggingen
Tel. + 41 61 751 90 91 | Fax + 41 61 751 63 54
info@artweger.com | www.artweger.com



Druck- und Satzfehler sowie technische Änderungen vorbehalten.
Typographical errors and technical changes reserved.
Sous réserve d'erreurs d'impression ou de syntaxe ainsi que de modifications techniques.
Drukfouten, maatwijzingen en technische veranderingen voorbehouden.
Ci riserviamo errori di stampa e variazioni tecniche.